

HW150A CR/HW170A CR

With EU Stage V Engine Installed



* Photo may include optional equipment.



Head Office(Sales Office)
14F, GLOBAL R&D CENTER, 477 BUNDANG SUSEO-RO, BUNDANG-GU, SEONGNAM-SI, GYEONGGI-DO, 13553, KOREA

PLEASE CONTACT

Gross Power
129 kW (173 hp) at 2,200 rpm

Net Power
127 kW (170 hp) at 2,200 rpm

Operating Weight
HW150A CR: 17,170 kg (37,850 lb)
HW170A CR: 18,820 kg (41,490 lb)

WHAT'S NEWEST AND BEST

THE BEST PRODUCTIVITY AND FUEL EFFICIENCY

- EU STAGE V Engine **NEW**
- Load Sensing Hydraulic System (LUDV) **NEW**
- Reversible Fan **NEW**
- Attachment Flow Control **Option**
- ECO Gauge
- Enlarged Air Inlet with Grill Cover
- Cycle Time Improvement

ULTIMATE DURABILITY

- Durable Cooling Module
- Reinforced Pin, Bush, and Polymer Shim
- Better Weight Balance
- Hi-grade (High-pressure) Hoses

EASY CONTROL AND COMFORTABLE OPERATION

- FNR and Ram lock switch on joystick **NEW**
- Bucket-Clamshell Adaptation **NEW Option**
- Proportional Joysticks and Pedal Control **NEW Option**
- Ride Control **NEW Option**
- Trailer Hitch Preparation **NEW Option**
- Efficient Climate Control **NEW Option**
- Tiltrotator Preparation **NEW Option**
- Automatic digging brake **NEW Option**
- Joystick steering **NEW Option**
- Swing Lock System **Option**
- Fine Swing Control **Option**
- Proportional Auxiliary Hydraulic Lines
- Intelligent and Wide Cluster
- Jog Dial Module
- USB-MP3-Handsfree Audio System

THE ULTIMATE SAFE ENVIROMENT

- Auto Safety Lock **NEW**
- Electronic Swing Parking Brake Control **NEW**
- Rear and Mirror view Camera **NEW Option**
- AAVM (Advanced Around View Monitoring) Camera System **Option**
- Cruise Control & Speed Limiter **NEW Option**
- Seatbelt Warning Alarm
- Cabin Suspension Mount

HW150A CR
HW170A CR

SERVICEABILITY AND TELEMATICS

- Hi MATE **Option**
- ECD(Engine Connected Diagnostics) **NEW**
- Mobile Fleet App
- Easy Access to DEF/AdBlue® Supply System
- HCE-DT Air **NEW**
- Longer Lasting Filter



*Photo may include optional equipment.



ENVIRONMENTALLY FRIENDLY FUEL EFFICIENCY

Reversible Fan **NEW**

The HW A Series provides excellent cooling performance by increasing heat dissipation and can be easily cleaned.



Attachment Flow Control

Option

The HW A Series optimizes attachments for effective flow rate setting depending on attachments (ten breaker types and ten crusher types), enabling various operations matching the site environments.



ECO Gauge

The operator can easily check the fuel consumption status from the ECO GAUGE in the cluster. Hourly and daily based fuel consumption can be checked in the detailed menu as well.



Enlarged Air Inlet with Grill Cover

Enlarged vent hole of the air inlet side cover and fine net grill to prevent penetration of foreign materials further improve durability.



THE BEST PRODUCTIVITY AND FUEL EFFICIENCY

HW A Series is equipped with eco-friendly, high-performance engines that meet the EU Stage V emission requirements.

EU STAGE V CERTIFIED ENGINE

Cummins B4.5 engine is satisfying the most strict environmental emission regulation in the world. (Reduction in PM 60%)

EU STAGE V Engine **NEW**

Now in its fourth decade of continuous improvement, the B4.5 for 2019 features an EGR-free design that delivers 5 percent more power and 31 percent more peak torque than the current model. Increased fuel economy and longer maintenance intervals contribute to a reduced cost of operation.



Load Sensing Hydraulic System (LUDV) **NEW**

It can minimize hydraulic shock phenomenon at combined operation and provide improved combined controllability especially travel with attachment.

Cycle Time Improvement

The HW A Series provides higher productivity on the site by faster operation: it loads trucks up to 2% faster than the 9 Series.

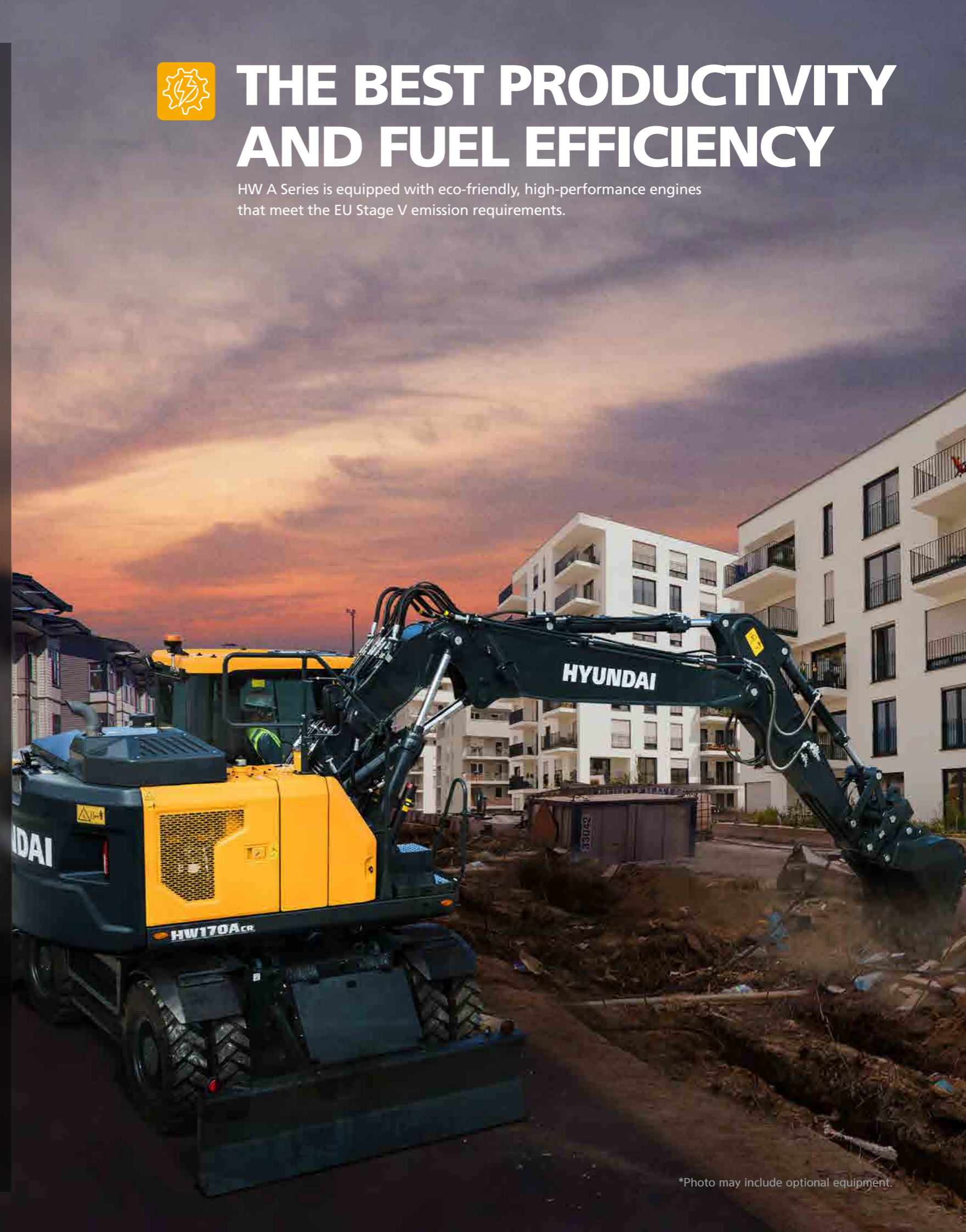

*Photo may include optional equipment.



ULTIMATE DURABILITY

The true value of the HW A Series lies in its durability. The robust upper and lower frame structure can endure external shock and heavy work loads. Attachments performance has been proven through rigorous field testing. No matter how tough the working environment is, you can always rely on the HYUNDAI Excavator A Series.



Hi-grade (High-pressure) Hoses

The HW A Series uses high-pressure hoses with improved heat and pressure resistance, greatly increasing the durability of the equipment.



Durable Cooling Module

The HW A Series has a durable cooling module that passed stringent tests, demonstrating the highest productivity in tough working environments.

Better weight balance

The upper and lower frames has been moved forward from the center of the swing and the swing support height has been lowered to optimize weight balance and reduce the tail swing radius.



Reinforced Pin, Bush, and Polymer Shim

The HW A series improves lubricity of connecting parts between the equipment and attachments. Gaps with attachments are minimized by wear-resistant long-life pins, bushes, and polymer shims, supporting the highest performance with invariable durability.



*Photo may include optional equipment.

*Photo may include optional equipment.

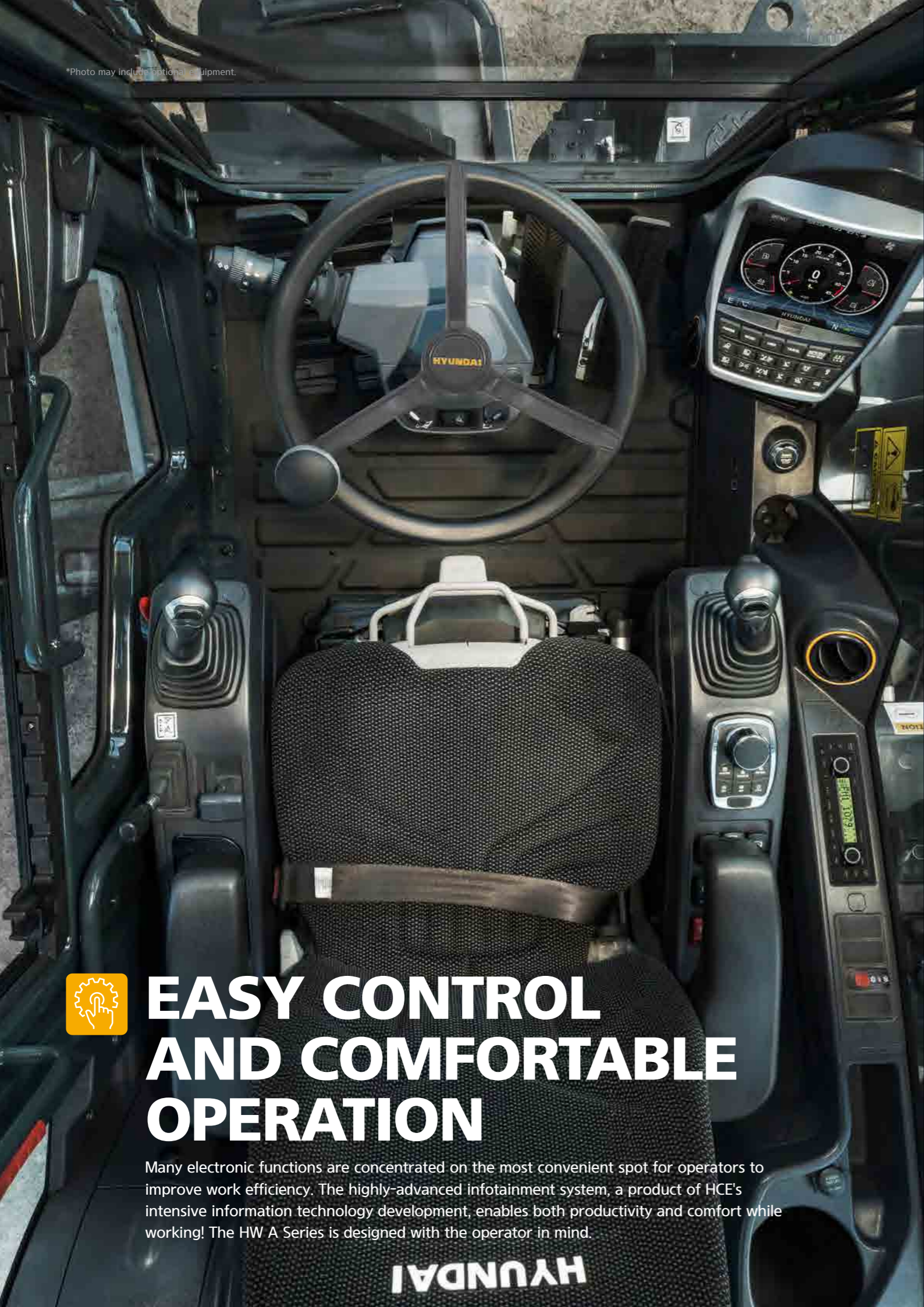

EASY CONTROL AND COMFORTABLE OPERATION

Many electronic functions are concentrated on the most convenient spot for operators to improve work efficiency. The highly-advanced infotainment system, a product of HCE's intensive information technology development, enables both productivity and comfort while working! The HW A Series is designed with the operator in mind.

HYUNDAI

FNR and Ram Lock Switch on Joystick **NEW** **Option**

It is easy to control FNR and Ram Lock, because the switches for the options are located on joystick.



Ram Lock Switch

FNR Switch

Bucket-Clamshell Adaptation **NEW** **Option**

To use the clamshell grab, various parts including the 3 way valve are installed on equipment. The equipment can use the clamshell grab instead of the bucket.

Efficient Climate Control **NEW** **Option**

With further improved air conditioning and heating, the HW A Series increases the APTC capacity by 15% to provide a pleasant environment for operators all the time. The ventilation was designed such that warm and cool air even reach operators' faces (increasing their work satisfaction) or allowing pleasant working environment.



Tiltrotator Preparation **NEW** **Option**

It can maximize the utilization of the equipment in a limited space, helping to improve task efficiency and task productivity.

Proportional Auxiliary Hydraulic Lines

Proportional control switch with better speed control helps operators to enlarge the operation convenience whenever they do time-consuming work. And this function can be switched with pedal valve in cluster setting menu. Newly added detent function allows an operator to continue using 2 way piping flow even if the operator does not keep pressing proportional control switch.

Jog Dial Module

The integrated jog dial module applies to the accelerator, remote air conditioner controller and operation of the cluster, allowing convenient operation. In the event of failure of the jog dial module, the emergency mode is activated on the cluster to ensure fail-safe function.



Proportional Joysticks and Pedal Control **NEW** **Option**

Attachments can be controlled by proportional switch on the joystick or pedal for the attachments.



Trailer Hitch **NEW** **Option**

Trailer Hitch Preparation gives electric, hydraulic connectors for easily mounting a hitch hook.



Ride Control **NEW** **Option**

It helps the operator to drive smoothly by reducing the front attachment vibration. It also provides Boom Floating Function.



Automatic digging brake **NEW** **Option**

While mark on this option sign on cluster, the brake operates without pushing brake pedal.



Joystick steering **NEW** **Option**

While mark on this option sign on cluster, the joystick like the steering wheel can control wheels.



Swing Lock System **Option**

Swing lock system is provided to maintain stability when swing movement needs to be limited, improving operating speed and productivity.

Fine Swing Control **Option**

This option enables fine swing movement at the start and stop of operation.

Intelligent and Wide Cluster

The 8" capacitive-type display (like smart phone display) of HW A Series is delivering excellent legibility. The centralized switches on the display allow convenience of checking the urea level and temperature outside the cabin.



USB-MP3-Handsfree Audio System

Radio player, USB-based MP3 player, integrated Bluetooth hands-free feature, and built-in microphone allow convenient phone calls while in work and in transit. The radio player was moved to the right side from the rear, allowing easier access.



HW A Series with advanced technology ensures our safety on a construction site.



HW A Series excavators are products of HCE's spirit of initiative, creativity, and strong drive. HCE engineers, who are the best in the industry, have worked tirelessly to offer a zero-defect product. The new HW A Series reflects customers' needs in the field gleaned by thorough monitoring.

Auto Safety Lock **NEW**

It prevents unintended operation. If operator unlock safety lever when RCV lever is pressed, excavator is not controlled by RCV lever.

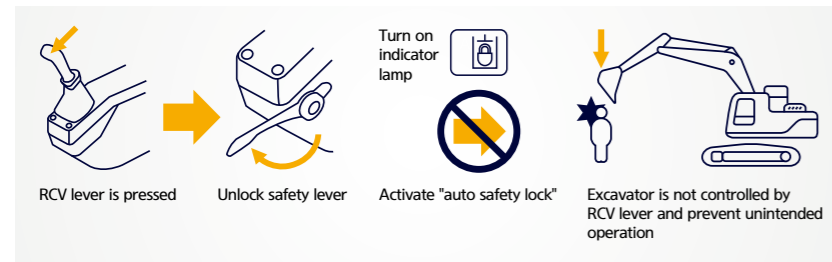

Electronic Swing Parking Brake Control **NEW**

An electronic valve and control system is applied to improve safety and utilization. The opening and closing time of the swing brake valve is controlled according to the sensing and control system.

AAVM(Advanced Around View Monitoring) Camera System **Option**

HW A Series has a state-of-the-art AAVM video camera system to secure field of vision for operators in all directions, thereby preventing accidents. Operators can easily check the workplace in the front and rear and to the right and left.

- **AAVM**(Advanced Around View Monitoring) : Secure field of vision in all directions by nine views including 3D bird's eye view and 2D/4CH view.
- **IMOD**(Intelligent Moving Object Detection) : Inform when people or dangerous objects are detected within the range of operation(recognition distance : 5 m).

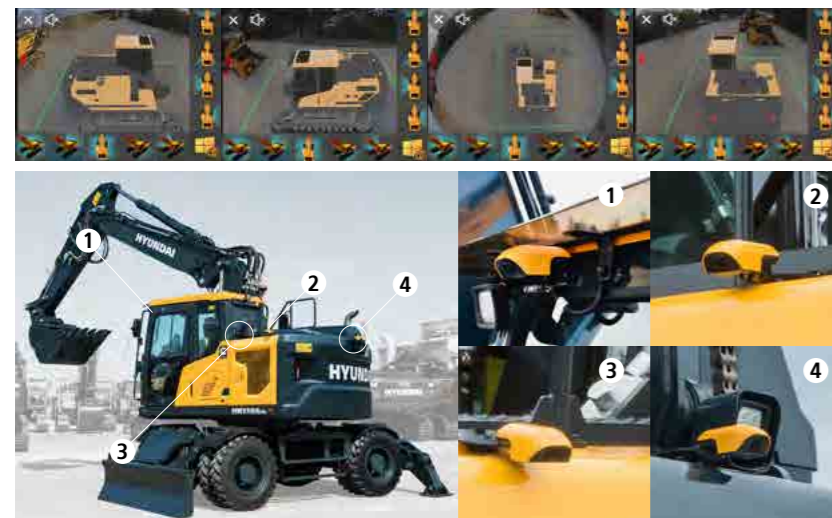

Rear and Mirror View Camera

NEW Option

Simple type mirror view with rear view camera option is available. This option helps the operator cover visual blind spot on the right side.



Cruise Control & Speed Limiter

NEW Option

HW A Series has an option to keep the driving speed without accelerator pedal and an option to limit max speed for local speed regulations.

Seatbelt Warning Alarm

If the seatbelt is not buckled when the ignition key is turned, an alarm is triggered in intervals along with a continuous visual alert. This emphasizes our priority for operator safety.

Cabin Suspension Mount

With a low-vibration design by the coil spring and damper inside the mount, the cab suspension mount of HW A Series reduces noise inside the cabin and improves durability, providing a comfortable operation space that lessens operators' fatigue.



THE ULTIMATE SAFE ENVIRONMENT

The true value of HW A Series lies in its durability. The robust frame structure and the attachments show the real value of HW A Series in tough working environments and promise higher productivity.

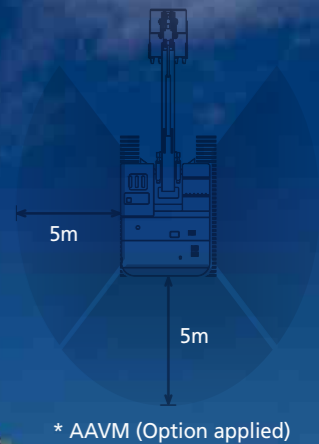

*Photo may include optional equipment.



SERVICEABILITY AND TELEMATICS

IoT / ICT / AI-based digital technology.
Creating a smart construction site. Maximizes connectivity, productivity, and safety for successful businesses.



*Photo may include optional equipment.

HiMATE

Option

IT'S CONVENIENT, EASY AND VALUABLE

Hi MATE Hyundai's newly developed remote management system, utilizes GPS-satellite technology to provide customers with the highest level of service and product support available. Hi MATE enables users to remotely evaluate machine performance, access diagnostic information, and verify machine locations at the touch of a button.

WHAT IS BENEFITS



Increase Productivity

It helps you operate machines in efficient. You can check the difference between total engine hours and actual working hours. See how productive your machines are and plan any required cost saving solutions. Hi MATE offers working information such as working / idling hours, fuel consumption and rate.



Convenient and Easy Monitoring

There is nothing much to do to monitor your machines. Just log on to the Hi MATE website or mobile application. Hi MATE allows you to watch your machines whenever and wherever you are.



Security

Protect your machines from theft or unauthorized usage with Hi MATE. If the machine moves out of the Geo-fence boundary, you will get alerts.

ECD(Engine Connected Diagnostics) **NEW** Option

ECD will support the after sales technicians and dealers with a diagnostics report (via e-mail, mobile, app or Hi MATE) on the engine performance. This will help after sales technicians arrive on site with the necessary tools and parts to fix troubles in one visit.

ECD is an integrated remote diagnostics service between Cummins cloud and Hi MATE cloud.

We are all connected



One Stop Solution



Just in 5 Minutes

from fault generation to report

Mobile Fleet App. **Option**

The new Mobile App is optimized to fleet management. It provides productivity, health insights based on telematics technology and enables fleet owner just focus on most wanted equipment in view of economical usage, utilization, fault codes and maintenance.

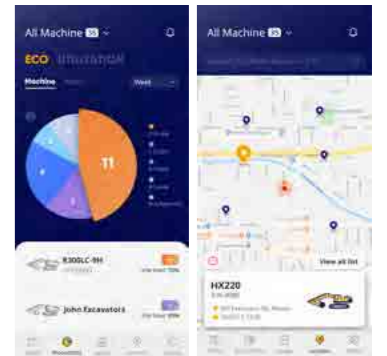

'Hi MATE Fleet Manager' App

HCE-DT Air **NEW**

HCE-DT Air connects you and your equipment wirelessly via smartphone and laptop right on site. You can diagnose root causes and troubleshoot for fault codes through the connection.

Easy Access to DEF/AdBlue® Supply System

The DEF/AdBlue® tank is installed inside the tool box and its inlet is remotely located for easy access and convenient supply.



2X Longer Lasting Filter

The length of product life period is improved from 500 hours to 1,000hours. (when using CK-4 engine oil)

- Engine Oil Filter (to 800 hours)
- Engine Oil (to 800 hours)
- Pre-filter
- Fuel Filter



SPECIFICATIONS

ENGINE

Maker / Model	CUMMINS / B4.5
Type	4 cylinder, water cooled, 4-cycle, turbocharged charge air cooled, direct injection, electronic controlled diesel engine.
Gross Power	129 kW (173 hp) at 2,200 rpm
Net Power	127 kW (170 hp) at 2,200 rpm
Max. Power	129 kW (173 hp) at 2,200 rpm
Peak Torque	780 N · m (575 lb.ft) at 1,500 rpm
Displacement	4.5 l (275 cu in)

HYDRAULIC SYSTEM

Advanced Load Sensing System(LUDV)
Load independent flow sharing

MAIN PUMP

Type	Variable displacement pump
Max. flow	260 lpm @ 1,800 rpm

AUX PUMP FOR STEERING OR ROTATION PIPING

Type	Piston pumps
Max. flow	60 lpm

HYDRAULIC MOTORS

Travel	Bent - axis pistons motor
Swing	Radial Piston Motor

RELIEF VALVE SETTING

Implement circuits	350 kgf/cm ² (4,970 psi)
Travel	400 kgf/cm ² (5,690 psi)
Power boost (boom, arm, bucket)	380 kgf/cm ² (5,400 psi)
Pilot circuit	40 kgf/cm ² (570 psi)
Service valve	Installed

HYDRAULIC CYLINDERS

Model	HW150ACR	HW170ACR
Arm	1-115 x 1,138 mm	1-120 x 1,235 mm
Bucket	1-100 x 850 mm	1-105 x 995 mm
Blade	2-110 x 235 mm	2-110 x 235 mm
Outrigger	2-125 x 463 mm	2-125 x 463 mm
No. of cylinder bore X stroke		
Mono boom	1-105 x 1,105mm	
2-PCS boom	2-105 x 992mm	2-110 x 992mm
Adjust (boom)	1-145 x 634mm	1-160 x 624mm

* Hyundai Bio Hydraulic Oil (HBHO) available

DRIVES & BRAKES

4-wheel hydrostatic drive. Constant mesh, helical gear transmission provides 2 forward and reverse travel speeds.

Max. drawbar pull	10,720 kgf (23,636 lbf)
Travel speed	1st 9.5 km/h 2nd 35 km/h or 20 km/h (Option)
Gradeability	30°

Service Brake :

- Independent dual brake, front and rear axle full hydraulic power brake.
- Spring released and hydraulic applied wet type multiple disc brake.

Parking Brake :

- Spring applied and hydraulic released wet disc brake type in transmission.

CONTROL

Pilot pressure operated joysticks and pedals with detachable lever provide almost effortless and fatigueless operation.

Pilot control	Two joysticks with one safety lever (LH): Swing and arm, (RH): Boom and bucket (ISO)
Engine throttle	Electric, Dial type
Lights	Two lights mounted on the boom, one under the battery box and one under the cabin

AXLE & WHEEL

Full floating front axle is supported by center pin for oscillation. It can be locked by oscillation lock cylinders. Rear axle is fixed on the lower chassis.

Tires	10.00-20-14PR, Dual(tube type)
(Optional)	10.00-20, Dual(solid type) 10.00-20-16PR, Dual(tube type)

STEERING SYSTEM

Hydraulically actuated, orbitrol type steering system actuates on front wheels through the steering cylinders.

Min. turning radius	6,280 (20' 7") mm
---------------------	-------------------

SWING SYSTEM

Swing motor	Fixed displacement radial piston motor
Swing bearing lubrication	Grease-bathed
Swing brake	Multi wet disc
Swing speed	9.3rpm

COOLANT & LUBRICANT CAPACITY

	liter	US gal	UK gal
Fuel tank	200	52.8	44.0
Engine coolant	19.5	5.2	4.3
Engine oil	11	2.9	2.4
Swing device - grease	1.2	0.32	0.26
Axle			
Front	15.5	4.09	3.41
Rear	17.5	4.62	3.85
Transmission	2.5	0.7	0.5
Hydraulic system (including tank)	187	49.4	41.1
Hydraulic tank	103	27.2	22.7
DEF/AdBlue®	48	12.7	10.6

UNDERCARRIAGE

Reinforced box-section frame is all-welded, low-stress. Dozer blade and outriggers are available. A pin-on design.

Dozer blade	A very useful addition for leveling and back filling or clean-up work.
Outrigger	Indicated for max. operation stability when digging and lifting. Can be mounted on the front/or the rear.

OPERATING WEIGHT (APPROXIMATE)

HW150ACR Operating weight, including 4,710mm(16' 5") 2-piece boom, 2,450mm(8' 0") arm, SAE heaped 0.71 m³(0.93yd³) backhoe bucket, lubricant, coolant, full fuel tank, hydraulic tank and the standard equipment.

HW170ACR Operating weight, including 5,000mm(16' 5") 2-piece boom, 2,450mm(8' 0") arm, SAE heaped 0.89m³(1.16yd³) backhoe bucket, lubricant, coolant, full fuel tank, hydraulic tank and the standard equipment.

OPERATING WEIGHT

Model	HW150ACR	HW170ACR
Rear dozer blade	17,170 kg (37,850 lb)	18,820 kg (41,490 lb)
Rear outrigger	17,440 kg (38,450 lb)	19,090 kg (42,090 lb)
Front outrigger and rear blade	18,390 kg (40,540 lb)	20,040 kg (44,180 lb)
Front blade and rear outrigger	18,390 kg (40,540 lb)	20,040 kg (44,180 lb)

AIR CONDITIONING SYSTEM

The air condition system for the machine contains the fluorinated greenhouse gas with global warming potential of R134a. (Global Warming Potential : 1,430)

The system hold 0.65kg refrigerant consisting of a CO₂ equivalent 0.93kg metric tonne. For more information, Please refer to the manual.

DIMENSIONS & WORKING RANGE

HW150A CR MONO BOOM DIMENSIONS

4.6m (15' 1") Mono boom, 2.0m (6' 7"), 2.45m (8' 0"), 2.6m (8' 6") Arm, Rear dozer

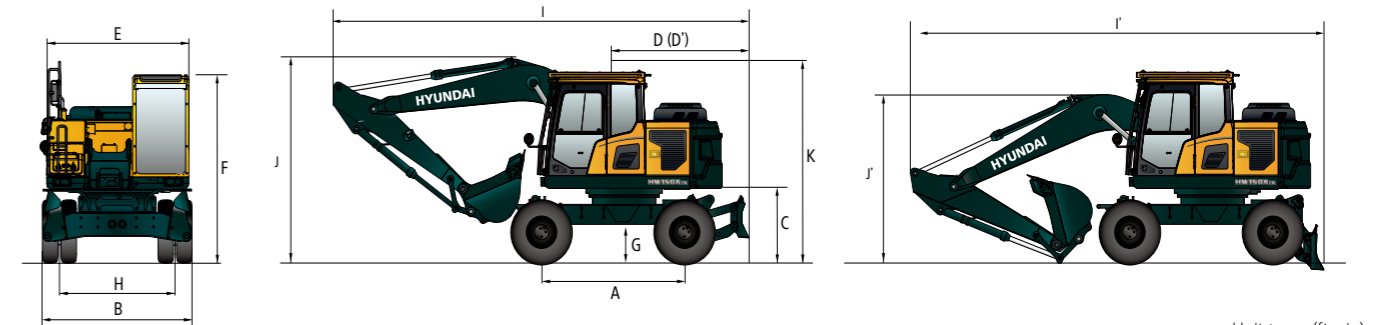

Unit : mm (ft · in)

A Wheel base	2,600 (8' 6")
B Overall width	2,530 (8' 4")
C Ground clearance of counterweight	1,265 (4' 2")
D Rear-end distance	1,790 (5' 10")
D' Rear-end swing radius	1,800 (5' 11")
E Upperstructure width	2,500 (8' 6")
F Overall height of cab	3,230 (10' 7")
G Min. ground clearance	370 (1' 3")
H Tread	1,944 (6' 5")
K Overall height of guardrail	3,450(11' 4")

Boom length	4,600 (15' 1")
Arm length	2,000 (6' 7") 2,450 (8' 0") 2,600 (8' 6")
I Overall length (Traveling position)	7,885 (25'10") 7,710 (25' 4") 7,610 (25' 0")
I' Overall length (Shipping position)	7,780 (25' 6") 7,830 (25' 8") 7,845 (25' 9")
J Overall height of boom (Traveling position)	3,270 (10' 9") 3,790 (12' 5") 3,930 (12' 11")
J' Overall height of boom (Shipping position)	2,820 (9' 3") 2,990 (9' 10") 3,110 (10' 2")

HW150A CR MONO BOOM WORKING RANGE

Unit : mm (ft · in)

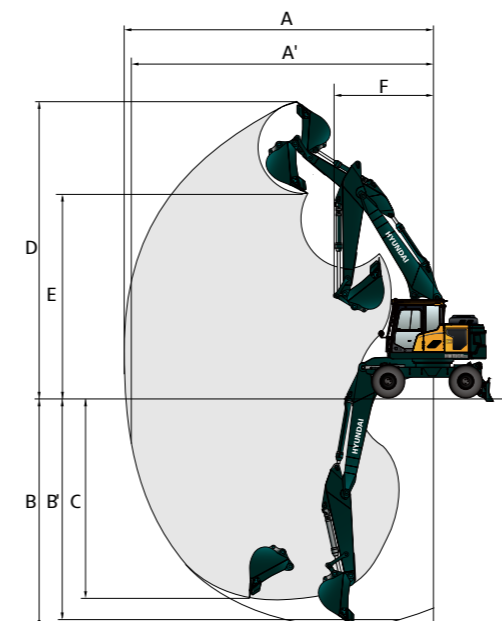

Boom length	4,600 (15' 1")
Arm length	2,000 (6' 7") 2,450 (8' 0") 2,600 (8' 6")
A Max. digging reach	7,940 (26' 1") 8,370 (27' 6") 8,520 (27' 11")
A' Max. digging reach on ground	7,710 (25' 4") 8,150 (26' 9") 8,300 (27' 3")
B Max. digging depth	4,680 (15' 4") 5,130 (16' 10") 5,280 (17' 4")
B' Max. digging depth (8' level)	4,425 (14' 6") 4,920 (16' 2") 5,070 (16' 8")
C Max. vertical wall digging depth	4,220 (13' 10") 4,675 (15' 4") 4,820 (15' 10")
D Max. digging height	8,520 (27' 11") 8,830 (29' 0") 8,920 (29' 3")
E Max. dumping height	6,080 (19' 11") 6,380 (20' 11") 6,470 (21' 3")
F Min. swing radius	2,650 (8' 8") 2,740 (9' 0") 2,755 (9' 0")

DIMENSIONS & WORKING RANGE

HW150A CR 2-PIECE BOOM DIMENSIONS

4.71m (15' 5") 2-Piece boom, 2.0m (6' 7"), 2.45m (8' 0"), 2.6m (8' 6") Arm, Rear dozer

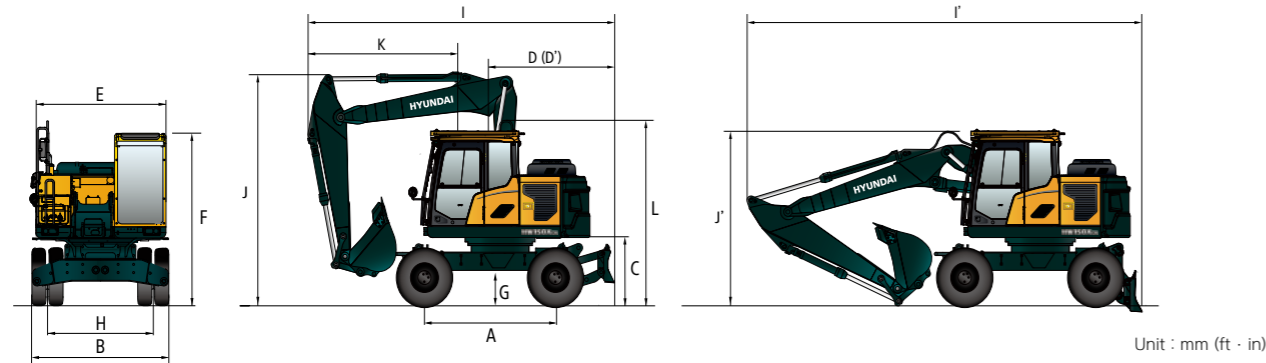

A	Wheel base	2,600 (8' 6")
B	Overall width	2,530 (8' 4")
C	Ground clearance of counterweight	1,265 (4' 2")
D	Rear-end distance	1,790 (5' 10")
D'	Rear-end swing radius	1,800 (5' 11")
E	Upperstructure width	2,500 (8' 6")
F	Overall height of cab	3,230 (10' 7")
G	Min. ground clearance	370 (1' 3")
H	Tread	1,944 (6' 5")
L	Overall height of guardrail	3,450 (11' 4")

Boom length	4,710 (15' 5")			
Arm length	2,000 (6' 7")	2,450 (8' 0")	2,600 (8' 6")	
I	Overall length (Traveling position)	5,980 (19' 7")	5,940 (19' 6")	5,920 (19' 5")
I'	Overall length (Shipping position)	7,940 (26' 1")	7,945 (26' 1")	7,950 (26' 1")
J	Overall height of boom (Traveling position)	3,980 (13' 1")	3,970 (13' 0")	3,980 (13' 1")
J'	Overall height of boom (Shipping position)	2,940 (9' 8")	2,990 (9' 10")	3,040 (10' 0")
K	End of attachment to steering wheel	2,695 (8' 10")	2,665 (8' 9")	2,635 (8' 8")

HW150A CR 2-PIECE BOOM WORKING RANGE

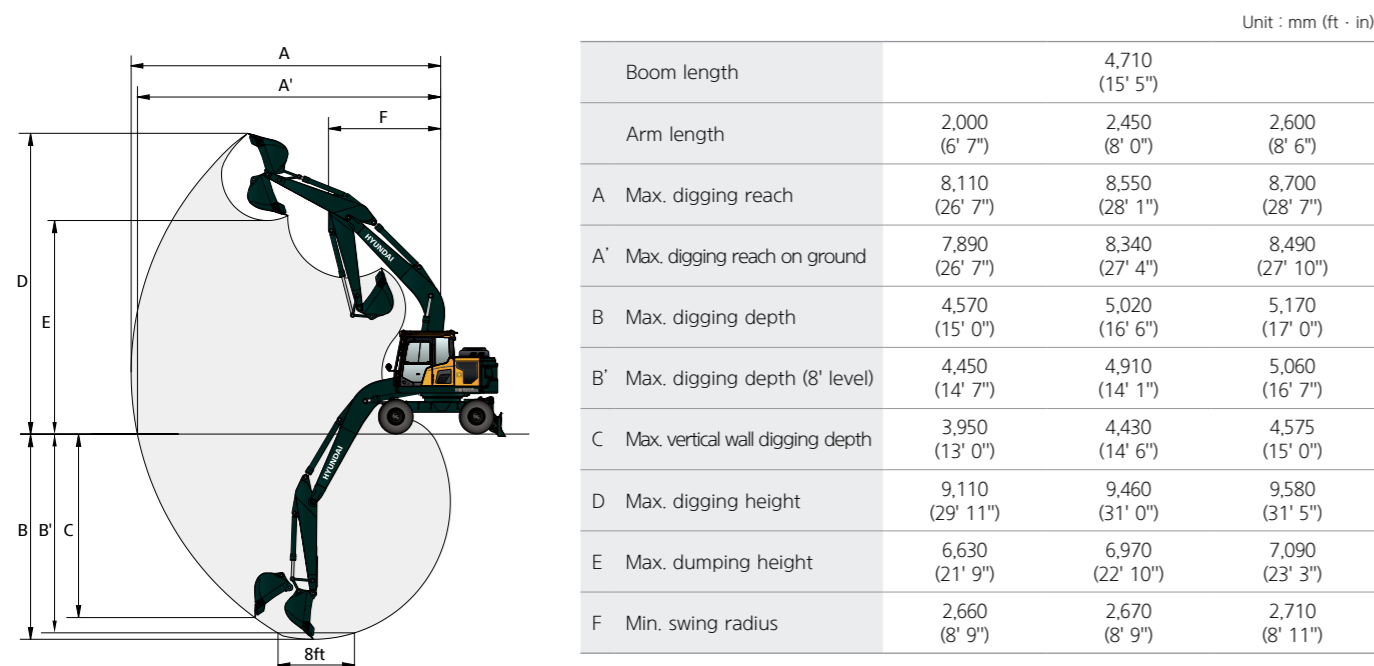

Boom length	4,710 (15' 5")			
Arm length	2,000 (6' 7")	2,450 (8' 0")	2,600 (8' 6")	
A	Max. digging reach	8,110 (26' 7")	8,550 (28' 1")	8,700 (28' 7")
A'	Max. digging reach on ground	7,890 (26' 7")	8,340 (27' 4")	8,490 (27' 10")
B	Max. digging depth	4,570 (15' 0")	5,020 (16' 6")	5,170 (17' 0")
B'	Max. digging depth (8' level)	4,450 (14' 7")	4,910 (14' 1")	5,060 (16' 7")
C	Max. vertical wall digging depth	3,950 (13' 0")	4,430 (14' 6")	4,575 (15' 0")
D	Max. digging height	9,110 (29' 11")	9,460 (31' 0")	9,580 (31' 5")
E	Max. dumping height	6,630 (21' 9")	6,970 (22' 10")	7,090 (23' 3")
F	Min. swing radius	2,660 (8' 9")	2,670 (8' 9")	2,710 (8' 11")

DIMENSIONS & WORKING RANGE

HW170A CR 2-PIECE BOOM DIMENSIONS

5.0m (16' 5") 2-Piece boom, 2.0m (6' 7"), 2.45m (8' 0"), 2.6m (8' 6") Arm, Rear dozer

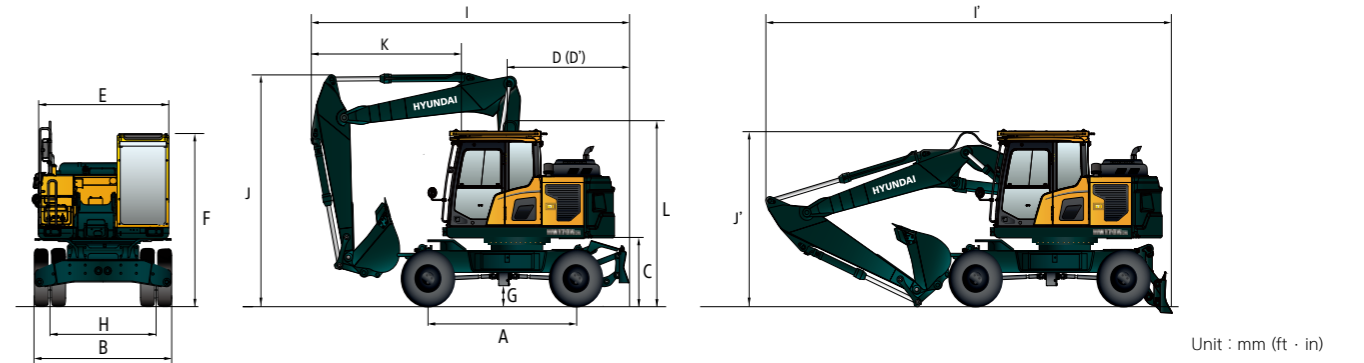

A	Wheel base	2,600 (8' 6")
B	Overall width (STD / Wide axle)	2,530 (8' 4") / 2,700 (8' 10")
C	Ground clearance of counterweight	1,265 (4' 2")
D	Rear-end distance	1,830 (6' 0")
D'	Rear-end swing radius	1,830 (6' 0")
E	Upperstructure width	2,500 (8' 6")
F	Overall height of cab	3,220 (10' 7")
G	Min. ground clearance	370 (1' 3")
H	Tread	1,944 (6' 5")
L	Overall height of guardrail	3,450 (11' 4")

Boom length	5,000 (16' 5")			
Arm length	2,000 (6' 7")	2,450 (8' 0")	2,600 (8' 6")	
I	Overall length (Traveling position)	6,340 (20' 10")	6,310 (20' 8")	6,250 (20' 6")
I'	Overall length (Shipping position)	8,330 (27' 4")	8,290 (27' 2")	8,250 (27' 1")
J	Overall height of boom (Traveling position)	4,000 (13' 1")	3,990 (13' 1")	4,000 (13' 1")
J'	Overall height of boom (Shipping position)	3,190 (10' 6")	3,150 (10' 4")	3,400 (11' 2")
K	End of attachment to steering wheel	3,050 (10' 0")	3,030 (9' 11")	2,960 (9' 9")

HW170A CR 2-PIECE BOOM WORKING RANGE

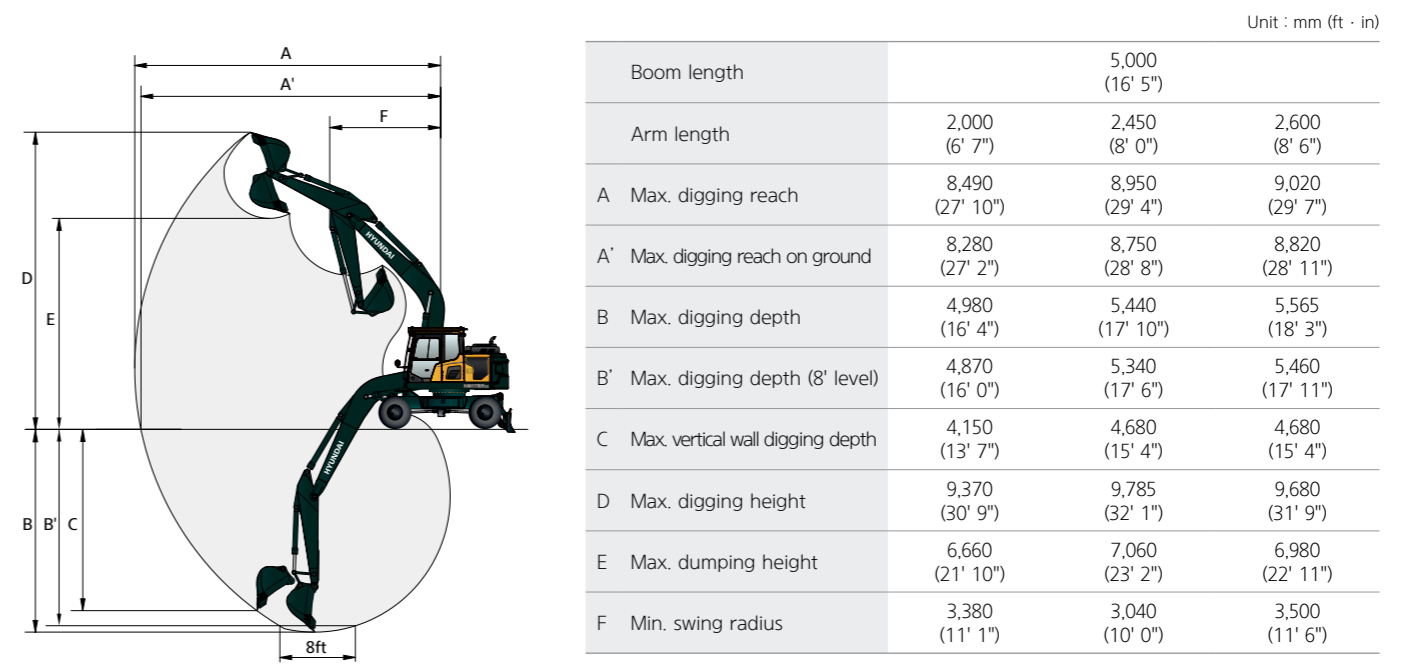

Boom length	5,000 (16' 5")			
Arm length	2,000 (6' 7")	2,450 (8' 0")	2,600 (8' 6")	
A	Max. digging reach	8,490 (27' 10")	8,950 (29' 4")	9,020 (29' 7")
A'	Max. digging reach on ground	8,280 (27' 2")	8,750 (28' 8")	8,820 (28' 11")
B	Max. digging depth	4,980 (16' 4")	5,440 (17' 10")	5,565 (18' 3")
B'	Max. digging depth (8' level)	4,870 (16' 0")	5,340 (17' 6")	5,460 (17' 11")
C	Max. vertical wall digging depth	4,150 (13' 7")	4,680 (15' 4")	4,680 (15' 4")
D	Max. digging height	9,370 (30' 9")	9,785 (32' 1")	9,680 (31' 9")
E	Max. dumping height	6,660 (21' 10")	7,060 (23' 2")	6,980 (22' 11")
F	Min. swing radius	3,380 (11' 1")	3,040 (10' 0")	3,500 (11' 6")

LIFTING CAPACITY



HW150A CR MONO BOOM

4.6m (15' 1") Mono boom, 2.00m (6' 7") arm equipped with 3,250kg counter weight, dozer down.

Lift-point height m (ft)	Lift-point radius									
	1.5m (4.9ft)		3.0m (9.8ft)		4.5m (14.8ft)		6.0m (19.7ft)		At max. reach	
	Capacity	Reach	Capacity	Reach	Capacity	Reach	Capacity	Reach	Capacity	Reach
6.0m 19.7ft	kg lb			*4,420 9,740	4,350 9,590			*3,340 7,360	*3,340 7,360	5.19 (17.0)
4.5m 14.8ft	kg lb			*4,810 10,600	4,240 9,350	*3,870 8,530	2,710 5,970	*3,120 6,880	2,610 5,750	6.13 (20.1)
3.0m 9.8ft	kg lb			*5,800 12,790	4,020 8,860	4,190 9,240	2,640 5,820	*3,150 6,940	2,290 5,050	6.59 (21.6)
1.5m 4.9ft	kg lb			6,280 13,850	3,800 8,380	4,090 9,020	2,550 5,620	*3,380 7,450	2,190 4,830	6.68 (21.9)
0.0m 0.0ft	kg lb			*6,020 13,270	*6,020 13,270	6,150 13,560	3,680 8,110	4,030 8,880	2,500 5,510	6.42 (21.0)
-1.5m -4.9ft	kg lb	*6,310 13,910	*6,310 13,910	*9,650 21,270	6,750 14,880	6,150 13,560	3,680 8,110	4,310 9,500	2,670 5,890	5.74 (18.8)
-3.0m -9.8ft	kg lb			*7,160 15,790	6,940 15,300			*4,610 10,160	3,860 8,510	4.46 (14.6)

4.6m (15' 1") Mono boom, 2.00m (6' 7") arm equipped with 3,250kg counter weight, dozer up.

Lift-point height m (ft)	Lift-point radius									
	1.5m (4.9ft)		3.0m (9.8ft)		4.5m (14.8ft)		6.0m (19.7ft)		At max. reach	
	Capacity	Reach	Capacity	Reach	Capacity	Reach	Capacity	Reach	Capacity	Reach
6.0m 19.7ft	kg lb			*4,420 9,740	3,930 8,660			*3,340 7,360	3,100 6,830	5.19 (17.0)
4.5m 14.8ft	kg lb			*4,810 10,600	3,830 8,440	*3,870 8,530	2,440 5,380	*3,120 6,880	2,350 5,180	6.13 (20.1)
3.0m 9.8ft	kg lb			*5,800 12,790	3,610 7,960	4,190 9,240	2,380 5,250	*3,150 6,940	2,050 4,520	6.59 (21.6)
1.5m 4.9ft	kg lb			6,280 13,850	3,390 7,470	4,090 9,020	2,290 5,050	*3,380 7,450	1,970 4,340	6.68 (21.9)
0.0m 0.0ft	kg lb			*6,020 13,270	5,860 12,920	6,150 13,560	3,280 7,230	4,030 8,880	2,240 4,940	6.42 (21.0)
-1.5m -4.9ft	kg lb	*6,310 13,910	*6,310 13,910	*9,650 21,270	5,920 13,050	6,150 13,560	3,280 7,230	4,310 9,500	2,390 5,270	5.74 (18.8)
-3.0m -9.8ft	kg lb			*7,160 15,790	6,090 13,430			*4,610 10,160	3,450 7,610	4.46 (14.6)

4.6m (15' 1") Mono boom, 2.45m (8' 0") arm equipped with 3,250kg counter weight, dozer down.

Lift-point height m (ft)	Lift-point radius									
	1.5m (4.9ft)		3.0m (9.8ft)		4.5m (14.8ft)		6.0m (19.7ft)		At max. reach	
	Capacity	Reach	Capacity	Reach	Capacity	Reach	Capacity	Reach	Capacity	Reach
7.5m 24.6ft	kg lb							*2,900 6,390	*2,900 6,390	4.19 (13.7)
6.0m 19.7ft	kg lb							*2,400 5,290	*2,400 5,290	5.74 (18.8)
4.5m 14.8ft	kg lb					*4,340 9,570	4,300 9,480	*3,870 8,530	2,740 6,040	6.60 (21.7)
3.0m 9.8ft	kg lb			*8,000 17,640	7,500 16,530	*5,370 11,840	4,060 8,950	4,200 9,260	2,650 5,840	7.03 (23.1)
1.5m 4.9ft	kg lb			*5,100 11,240	*5,100 11,240	6,300 13,890	3,810 8,400	4,080 8,990	2,540 5,600	7.12 (23.3)
0.0m 0.0ft	kg lb			*6,320 13,930	*6,320 13,930	6,130 13,510	3,660 8,070	4,000 8,820	2,470 5,450	6.87 (22.5)
-1.5m -4.9ft	kg lb	*5,450 12,020	*5,450 12,020	*10,200 22,490	6,650 14,660	6,090 13,430	3,620 7,980	3,990 8,800	2,460 5,420	6.24 (20.5)
-3.0m -9.8ft	kg lb			*8,180 18,030	6,800 14,990	*5,500 12,130	3,700 8,160	*4,460 9,830	3,140 6,920	5.10 (16.7)

- Lifting capacity are based on ISO 10567.
- Lifting capacity does not exceed 75% of tipping load with the machine on firm level ground or 87% of full hydraulic capacity.
- The Lift-point is bucket pivot mounting pin on the arm (without bucket mass).
- (*) indicates load limited by hydraulic capacity.

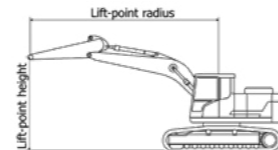

HW150A CR MONO BOOM

4.6m (15' 1") Mono boom, 2.45m (8' 0") arm equipped with 3,250kg counter weight, dozer up.

Lift-point height m (ft)	Lift-point radius										
	1.5m (4.9ft)		3.0m (9.8ft)		4.5m (14.8ft)		6.0m (19.7ft)		At max. reach		
	Capacity	Reach	Capacity	Reach	Capacity	Reach	Capacity	Reach	Capacity	Reach	
7.5m 24.6ft	kg lb									*2,900 6,390	4.19 (13.7)
6.0m 19.7ft	kg lb									*2,400 5,290	5.74 (18.8)
4.5m 14.8ft	kg lb					*4,340 9,570	4,300 9,480	*3,870 8,530	2,740 6,040	6.60 (21.7)	
3.0m 9.8ft	kg lb			*8,000 17,640	7,500 16,530	*5,370 11,840	4,060 8,950	4,200 9,260	2,650 5,840	7.03 (23.1)	
1.5m 4.9ft	kg lb			*5,100 11,240	*5,100 11,240	6,300 13,890	3,810 8,400	4,080 8,990	2,540 5,600	7.12 (23.3)	
0.0m 0.0ft	kg lb			*6,320 13,930	*6,320 13,930	6,130 13,510	3,660 8,070	4,000 8,820	2,470 5,450	6.87 (22.5)	
-1.5m -4.9ft	kg lb	*5,450 12,020	*5,450 12,020	*10,200 22,490	6,650 14,660	6,090 13,430	3,620 7,980	3,990 8,800	2,460 5,420	6.24 (20.5)	
-3.0m -9.8ft	kg lb			*8,180 18,030	6,800 14,990	*5,500 12,130	3,700 8,160	*4,460 9,830	3,140 6,920	5.10 (16.7)	

4.6m (15' 1") Mono boom, 2.60m (8' 6") arm equipped with 3,250kg counter weight, dozer down.

Lift-point height m (ft)	Lift-point radius										
	1.5m (4.9ft)		3.0m (9.8ft)		4.5m (14.8ft)		6.0m (19.7ft)		At max. reach		
	Capacity	Reach	Capacity	Reach	Capacity	Reach	Capacity	Reach	Capacity	Reach	
7.5m 24.6ft	kg lb									*2,670 5,890	4.43 (14.5)
6.0m 19.7ft	kg lb									*2,230 4,920	5.92 (19.4)
4.5m 14.8ft	kg lb					*4,190 9,240	*4,190 9,240	*3,770 8,310	2,750 6,060	*2,100 4,630	6.76 (22.2)
3.0m 9.8ft	kg lb			*7,640 16,840	7,570 16,690	*5,230 11,530	4,080 8,990	4,210 9,280	2,660 5,860	*2,120 4,670	7.18 (23.5)
1.5m 4.9ft	kg lb			*5,810 12,810	*5,810 12,810	6,310 13,910	3,820 8,420	4,080 8,990	2,540 5,600	*2,250 4,960	7.26 (23.8)
0.0m 0.0ft	kg lb			*6,390 14,090	*6,390 14,090	6,130 13,510	3,650 8,050	3,990 8,800	2,460 5,420	*2,540 5,600	7.01 (23.0)
-1.5m -4.9ft	kg lb	*5,220 11,510	*5,220 11,510	*10,050 22,160	6,610 14,570	6,070 13,380	3,610 7,960	3,970 8,750	2,440 5,380	*3,130 6,900	6.40 (21.0)
-3.0m -9.8ft	kg lb			*8,470 18,670	6,750 14,880	*5,700 12,570	3,670 8,090			*4,400 9,700	5.30 (17.4)

4.6m (15' 1") Mono boom, 2.60m (8' 6") arm equipped with 3,250kg counter weight, dozer up.

Lift-point height m (ft)	Lift-point radius										
	1.5m (4.9ft)		3.0m (9.8ft)		4.5m (14.8ft)		6.0m (19.7ft)		At max. reach		
	Capacity	Reach	Capacity	Reach	Capacity	Reach	Capacity	Reach	Capacity	Reach	
7.5m 24.6ft	kg lb									*2,670 5,890	4.43 (14.5)
6.0m 19.7ft	kg lb									*2,230 4,920	5.92 (19.4)
4.5m 14.8ft	kg lb					*4,190 9,240	3,900 8,600	*3,770 8,310	2,480 5,470	*2,100 4,630	6.76 (22.2)
3.0m 9.8ft	kg lb			*7,640 16,840	6,690 14,750	*5,230 11,530	3,660 8,070	4,210 9,280	2,390 5,270	*2,120 4,670	7.18 (23.5)
1.5m 4.9ft	kg lb			*5,810 12,810	*5,810 12,810	6,310 13,910	3,410 7,520	4,080 8,990	2,280 5,030	*2,250 4,960	7.26 (23.8)
0.0m 0.0ft	kg lb			*6,390 14,090	*5,780 12,740	6,130 13,510	3,250 7,170	3,990 8,800	2,200 4,850	*2,540 5,600	7.01 (23.0)
-1.5m -4.9ft	kg lb	*5,220 11,510	*5,220 11,510	*10,050 22,160	5,780 12,740	6,070 13,380	3,200 7,050	3,970 8,750	2,180 4,810	*3,130 6,900	6.40 (21.0)
-3.0m -9.8ft	kg lb			*8,470 18,670	5,910 13,030	*5,700 12,570	3,270 7,210			*4,400 9,700	5.30 (17.4)

- Lifting capacity are based on ISO 10567.
- Lifting capacity does not exceed 75% of tipping load with the machine on firm level ground or 87% of full hydraulic capacity.
- The Lift-point is bucket pivot mounting pin on the arm (without bucket mass).
- (*) indicates load limited by hydraulic capacity.

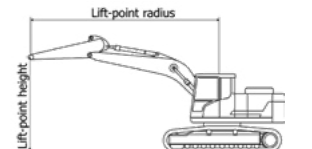

LIFTING CAPACITY



HW150A CR 2-PIECE BOOM

4.71m (15' 5") 2-Piece boom, 2.00m (6' 7") arm equipped with 3,250kg counter weight, dozer down.

Lift-point height m (ft)	Lift-point radius						At max. reach		
	3.0m (9.8ft)		4.5m (14.8ft)		6.0m (19.7ft)		Capacity	Reach	
	Over-front	Over-side	Over-front	Over-side	Over-front	Over-side	kg (lb)	m (ft)	
7.5m 24.6ft							*4,440	*4,440	3.71 (12.2)
6.0m 19.7ft			*4,210	*4,210			*3,480	3,200	5.41 (17.8)
4.5m 14.8ft	*5,850	*5,850	*4,650	4,240	*4,240	2,710	*3,210	2,470	6.32 (20.7)
3.0m 9.8ft			*10,250	9,350	*9,350	5,970	*7,080	5,450	
1.5m 4.9ft			*5,640	3,990	4,190	2,630	*3,180	2,180	6.77 (22.2)
0.0m 0.0ft			*12,430	8,800	9,240	5,800	*7,010	4,810	
-1.5m -4.9ft	*9,690	6,710	6,270	3,760	4,080	2,530	*3,350	2,090	6.86 (22.5)
			13,820	8,290	8,990	5,580	*7,390	4,610	
			6,140	3,640	4,020	2,470	3,530	2,190	6.60 (21.6)
			13,540	8,020	8,860	5,450	7,780	4,830	
			6,140	3,640			4,110	2,530	5.94 (19.5)
			13,540	8,020			9,060	5,580	

4.71m (15' 5") 2-Piece boom, 2.00m (6' 7") arm equipped with 3,250kg counter weight, dozer up.

Lift-point height m (ft)	Lift-point radius						At max. reach		
	3.0m (9.8ft)		4.5m (14.8ft)		6.0m (19.7ft)		Capacity	Reach	
	Over-front	Over-side	Over-front	Over-side	Over-front	Over-side	kg (lb)	m (ft)	
7.5m 24.6ft							*4,440	*4,440	3.71 (12.2)
6.0m 19.7ft			*4,210	3,940			*3,480	2,880	5.41 (17.8)
4.5m 14.8ft	*5,850	*5,850	*4,650	3,820	*4,240	2,440	*3,210	2,220	6.32 (20.7)
3.0m 9.8ft			*10,250	8,420	*9,350	5,380	*7,080	4,890	
1.5m 4.9ft			*5,640	3,570	4,190	2,360	*3,180	1,950	6.77 (22.2)
0.0m 0.0ft			*12,430	7,870	9,240	5,200	*7,010	4,300	
-1.5m -4.9ft	*9,690	5,860	6,270	3,350	4,080	2,260	*3,350	1,870	6.86 (22.5)
			13,820	7,390	8,990	4,980	*7,390	4,120	
			6,140	3,240	4,020	2,210	3,530	1,950	6.60 (21.6)
			13,540	7,140	8,860	4,870	7,780	4,300	
			6,140	3,240			4,110	2,260	5.94 (19.5)
			13,540	7,140			9,060	4,980	

4.71m (15' 5") 2-Piece boom, 2.45m (8' 0") arm equipped with 3,250kg counter weight, dozer down.

Lift-point height m (ft)	Lift-point radius								At max. reach		
	3.0m (9.8ft)		4.5m (14.8ft)		6.0m (19.7ft)		7.5m (24.6ft)		Capacity	Reach	
	Over-front	Over-side	Over-front	Over-side	Over-front	Over-side	Over-front	Over-side	kg (lb)	m (ft)	
7.5m 24.6ft									*3,050	*3,050	4.49 (14.7)
6.0m 19.7ft			*3,710	*3,710					*6,720	*6,720	5.97 (19.6)
4.5m 14.8ft			*8,180	*8,180	*4,210	*4,210	*3,880	2,730	*2,510	*2,510	6.80 (22.3)
3.0m 9.8ft			*5,530	*5,530	*9,280	*9,280	*8,550	6,020	*5,530	*5,530	
1.5m 4.9ft			*4,210	*4,210	*4,210	*4,210	*5,140	4,870	*2,330	2,210	6.80 (23.7)
0.0m 0.0ft			*5,230	4,040	4,200	2,630	*2,310	1,970	*5,090	4,340	
-1.5m -4.9ft			*11,530	8,910	9,260	5,800	*5,090	4,340	*2,410	1,890	7.30 (23.9)
			6,290	3,770	4,080	2,520	*2,410	1,890	*5,310	4,170	
			13,870	8,310	8,990	5,560	*5,310	4,170	*2,670	1,960	7.05 (23.1)
			*4,890	*4,890	6,120	3,620	3,990	2,440	*5,890	4,320	
			*10,780	*10,780	13,490	7,980	8,800	5,380	*3,210	2,230	6.45 (21.1)
			*8,930	6,600	6,080	3,590	3,980	2,430	*7,080	4,920	
			*19,690	14,550	13,400	7,910	8,770	5,360			

- Lifting capacity are based on ISO 10567.
- Lifting capacity does not exceed 75% of tipping load with the machine on firm level ground or 87% of full hydraulic capacity.
- The Lift-point is bucket pivot mounting pin on the arm (without bucket mass).
- (*) indicates load limited by hydraulic capacity.

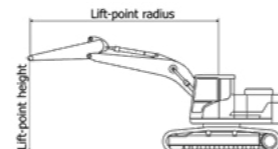

HW150A CR 2-PIECE BOOM

4.71m (15' 5") 2-Piece boom, 2.45m (8' 0") arm equipped with 3,250kg counter weight, dozer up.

Lift-point height m (ft)	Lift-point radius								At max. reach		
	3.0m (9.8ft)		4.5m (14.8ft)		6.0m (19.7ft)		7.5m (24.6ft)		Capacity	Reach	
	Over-front	Over-side	Over-front	Over-side	Over-front	Over-side	Over-front	Over-side	kg (lb)	m (ft)	
7.5m 24.6ft									*3,050	*3,050	4.49 (14.7)
6.0m 19.7ft			*3,710	*3,710					*6,720	*6,720	5.97 (19.6)
4.5m 14.8ft			*8,180	*8,180	*4,210	3,870	*3,880	2,460	*2,510	2,480	6.80 (22.3)
3.0m 9.8ft			*5,230	3,620	4,200	2,360	*2,310	1,760	*5,530	5,470	7.21 (23.7)
1.5m 4.9ft			*11,530	7,980	9,260	5,200	*5,090	3,880	*2,410	1,690	7.30 (23.9)
0.0m 0.0ft			6,290	3,360	4,080	2,250	*2,410	1,690	*5,310	3,730	
-1.5m -4.9ft			13,870	7,410	8,990	4,960	*5,310	3,730	*2,670	1,750	7.05 (23.1)
			*4,890	*4,890	6,120	3,210	3,990	2,180	*5,890	3,860	
			*10,780	*10,780	13,490	7,080	8,800	4,810	*3,210	1,980	6.45 (21.1)
			*8,930	5,760	6,080	3,180	3,980	2,160	*7,080	4,370	
			*19,690	12,700	13,400	7,010	8,770	4,760			

4.71m (15' 5") 2-Piece boom, 2.60m (8' 6") arm equipped with 3,250kg counter weight, dozer down.

Lift-point height m (ft)	Lift-point radius								At max. reach				
	1.5m (4.9ft)		3.0m (9.8ft)		4.5m (14.8ft)		6.0m (19.7ft)		7.5m (24.6ft)				
	Over-front	Over-side	Over-front	Over-side	Over-front	Over-side	Over-front	Over-side	Over-front	Over-side			
7.5m 24.6ft											*2,810	*2,810	4.73 (15.5)
6.0m 19.7ft			*3,420	*3,420							*6,190	*6,190	6.15 (20.2)
4.5m 14.8ft			*7,540	*7,540	*3,560	*3,560	*2,880	2,760	*2,330	*2,330	*5,140	*5,140	6.95 (22.8)
3.0m 9.8ft			*7,850	*7,850	*6,350	6,080	*5,140	4,700	*2,170	2,130	*4,780	4,700	7.36 (24.2)
1.5m 4.9ft			*4,060	*4,060	*3,780	2,750	*2,170	1,910	*2,250	1,840	*4,760	4,210	7.44 (24.4)
0.0m 0.0ft			*8,950	*8,950	*8,330	6,060	*2,160	1,910	*4,960	4,060	*2,480	1,900	7.20 (23.6)
-1.5m -4.9ft			*16,730	16,560	*11,220	8,950	*9,220	5,820	*5,470	4,190	*2,960	2,140	6.61 (21.7)
			*7,590	7,510	*5,090	4,060	*4,180	2,640	*6,530	4,720			
			*16,730	16,560	*11,220	8,950	*9,220	5,820					
			*6,200	3,780	4,080	2,520	*2,250	1,840					
			*13,670	8,330	8,990	5,560	*4,960	4,060					
			*4,980	*4,980	6,110	3,610	3,990	2,430					
			*10,980	*10,980	13,470	7,960	8,800	5,360					
			*8,600	6,560	6,060	3,570	3,960	2,420					
			*18,960	14,460	13,360	7,870	8,730	5,340					
					*5,860	3,640							
					*12,920	8,020							

4.71m (15' 5") 2-Piece boom, 2.60m (8' 6") arm equipped with 3,250kg counter weight, dozer up.

Lift-point height m (ft)	Lift-point radius								At max. reach				
	1.5m (4.9ft)		3.0m (9.8ft)		4.5m (14.8ft)		6.0m (19.7ft)		7.5m (24.6ft)				
	Over-front	Over-side	Over-front	Over-side	Over-front	Over-side	Over-front	Over-side	Over-front	Over-side			
7.5m 24.6ft											*2,810	*2,810	4.73 (15.5)
6.0m 19.7ft			*3,420	*3,420							*6,190	*6,190	6.15 (20.2)
4.5m 14.8ft			*7,540	*7,540	*3,560	*3,560	*2,880	2,490	*2,330	*2,330	*5,140	*5,140	6.95 (22.8)
3.0m 9.8ft			*7,850	*7,850	*6,350	6,080	*5,140	4,700	*2,170	1,910	*4,780	4,210	7.36 (24.2)
1.5m 4.9ft			*4,060	*4,060	*3,780	2,750	*2,170	1,910	*2,250	1,840	*4,760	4,210	7.44 (24.4)
0.0m 0.0ft			*8,950	*8,950	*8,330	6,060	*2,160	1,910	*4,960	4,060	*2,480	1,900	7.20 (23.6)
-1.5m -4.9ft			*16,730	14,590	*11,220	8,020	*9,220	5,220	*5,470	4,190	*2,960	2,140	6.61 (21.7)
			*7,590	6,620	*5,090	3,640	*4,180	2,370	*6,530	4,210			
			*16,730	14,590	*11,220	8,020	*9,220	5,220					
			*6,200	3,370	4,080	2,250	*2,250	1,640					
			*13,670	7,430	8,990	4,960	*4,960	3,620					
			*4,980	*4,980	6,110	3,200	3,990	2,170					
			*10,980	*10,980	13,470	7,050	8,800	4,780					
			*8,600	5,720	6,060	3,160	3,960	2,150					
			*18,960	12,610	13,360	6,970	8,730	4,740					
					*5,860	3,230							
					*12,920	7,120							

- Lifting capacity are based on ISO 10567.
- Lifting capacity does not exceed 75% of tipping load with the machine on firm level ground or 87% of full hydraulic capacity.
- The Lift-point is bucket pivot mounting pin on the arm (without bucket mass).
- (*) indicates load limited by hydraulic capacity.

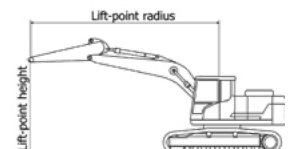

LIFTING CAPACITY



HW170A CR 2-PIECE BOOM

5.0m (16' 5") 2-Piece boom, 2.00 m (6' 7") arm equipped with 4,200kg counter weight, dozer down.

Lift-point height m (ft)	Lift-point radius						At max. reach		
	3.0m (9.8ft)		4.5m (14.8ft)		6.0m (19.7ft)		Capacity	Reach	
	Over-front	Over-side	Over-front	Over-side	Over-front	Over-side	kg (lb)	m (ft)	
7.5m 24.6ft							*4,790 *10,560	*4,790 *10,560	4.19 (13.8)
6.0m 19.7ft			*4,310 *9,500	*4,310 *9,500			*4,390 *9,680	3,240 7,140	5.75 (18.9)
4.5m 14.8ft			*4,930 *10,870	4,680 10,320	*4,350 *9,590	3,000 6,610	4,000 8,820	2,550 5,620	6.60 (21.7)
3.0m 9.8ft			*6,070 *13,380	4,350 9,590	4,560 10,050	2,880 6,350	3,570 7,870	2,250 4,960	7.03 (23.1)
1.5m 4.9ft			6,770 14,930	4,070 8,970	4,430 9,770	2,750 6,060	3,450 7,610	2,160 4,760	7.12 (23.4)
0.0m 0.0ft			6,630 14,620	3,940 8,690	4,340 9,570	2,680 5,910	3,600 7,940	2,240 4,940	6.87 (22.5)
-1.5m -4.9ft		*9,480 *20,900	7,320 16,140	6,630 14,620	3,950 8,710	2,690 5,930	4,140 9,130	2,570 5,670	6.24 (20.5)

5.0m (16' 5") 2-Piece boom, 2.00 m (6' 7") arm equipped with 4,200kg counter weight, dozer up.

Lift-point height m (ft)	Lift-point radius						At max. reach		
	3.0m (9.8ft)		4.5m (14.8ft)		6.0m (19.7ft)		Capacity	Reach	
	Over-front	Over-side	Over-front	Over-side	Over-front	Over-side	kg (lb)	m (ft)	
7.5m 24.6ft							*4,790 *10,560	*4,790 *10,560	4.19 (13.8)
6.0m 19.7ft			*4,310 *9,500	*4,310 *9,500			*4,390 *9,680	2,920 6,440	5.75 (18.9)
4.5m 14.8ft			*4,930 *10,870	4,220 9,300	*4,350 *9,590	2,700 5,950	4,000 8,820	2,290 5,050	6.60 (21.7)
3.0m 9.8ft			*6,070 *13,380	3,900 8,600	4,560 10,050	2,590 5,710	3,570 7,870	2,020 4,450	7.03 (23.1)
1.5m 4.9ft			6,770 14,930	3,620 7,980	4,430 9,770	2,460 5,420	3,450 7,610	1,930 4,250	7.12 (23.4)
0.0m 0.0ft			6,630 14,620	3,500 7,720	4,340 9,570	2,390 5,270	3,600 7,940	2,000 4,410	6.87 (22.5)
-1.5m -4.9ft		*9,480 *20,900	6,400 14,110	6,630 14,620	3,510 7,740	2,400 5,290	4,140 9,130	2,290 5,050	6.24 (20.5)

5.0m (16' 5") 2-Piece boom, 2.45 m (8' 0") arm equipped with 4,200kg counter weight, dozer down.

Lift-point height m (ft)	Lift-point radius								At max. reach		
	3.0m (9.8ft)		4.5m (14.8ft)		6.0m (19.7ft)		7.5m (24.6ft)		Capacity	Reach	
	Over-front	Over-side	Over-front	Over-side	Over-front	Over-side	Over-front	Over-side	kg (lb)	m (ft)	
7.5m 24.6ft									*2,760 *6,080	*2,760 *6,080	4.95 (16.2)
6.0m 19.7ft			*3,820 *8,420	*3,820 *8,420	*3,550 *7,830	3,070 6,770			*2,330 *5,140	*2,330 *5,140	6.31 (20.7)
4.5m 14.8ft			*4,470 *9,850	*4,470 *9,850	*4,010 *8,840	3,020 6,660			*2,180 *4,810	*2,180 *4,810	7.10 (23.3)
3.0m 9.8ft			*5,630 *12,410	4,410 9,720	*4,480 *9,880	2,880 6,350	*2,180 *4,810	2,020 4,450	*2,160 *4,760	2,020 4,450	7.50 (24.6)
1.5m 4.9ft			*6,770 *14,930	4,080 8,990	4,420 9,740	2,740 6,040	*2,940 *6,480	1,980 4,370	*2,260 *4,980	1,940 4,280	7.58 (24.9)
0.0m 0.0ft			6,600 14,550	3,910 8,620	4,310 9,500	2,640 5,820			*2,490 *5,490	2,010 4,430	7.35 (24.1)
-1.5m -4.9ft		*8,350 *18,410	7,170 15,810	6,560 14,460	3,880 8,550	4,280 9,440	2,620 5,780		*2,960 *6,530	2,250 4,960	6.77 (22.2)
-3.0m -9.8ft									*6,380 *14,070	3,970 8,750	

- Lifting capacity are based on ISO 10567.
- Lifting capacity does not exceed 75% of tipping load with the machine on firm level ground or 87% of full hydraulic capacity.
- The Lift-point is bucket pivot mounting pin on the arm (without bucket mass).
- (*) indicates load limited by hydraulic capacity.

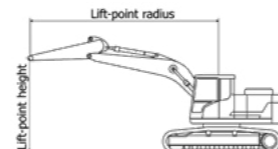

HW170A CR 2-PIECE BOOM

5.0m (16' 5") 2-Piece boom, 2.45 m (8' 0") arm equipped with 4,200kg counter weight, dozer up.

Lift-point height m (ft)	Lift-point radius						At max. reach		
	3.0m (9.8ft)		4.5m (14.8ft)		6.0m (19.7ft)		Capacity	Reach	
	Over-front	Over-side	Over-front	Over-side	Over-front	Over-side	kg (lb)	m (ft)	
7.5m 24.6ft			*4,040 *8,910	*4,040 *8,910			*3,280 *7,230	*3,280 *7,230	4.95 (16.2)
6.0m 19.7ft			*3,820 *8,420	*3,820 *8,420	*3,900 *8,600	2,770 6,110	*2,780 *6,130	2,510 5,530	6.31 (20.7)
4.5m 14.8ft			*4,470 *9,850	4,290 9,460	*4,010 *8,840	2,730 6,020	*2,600 *5,730	2,030 4,480	7.10 (23.3)
3.0m 9.8ft			*5,630 *12,410	3,950 8,710	*4,480 *9,880	2,590 5,710	*2,590 *5,710	1,810 3,990	7.50 (24.6)
1.5m 4.9ft			*6,770 *14,930	3,640 8,020	4,420 9,740	2,450 5,400	*2,700 *5,950	1,730 3,810	7.58 (24.9)
0.0m 0.0ft			6,600 14,550	3,470 7,650	4,310 9,500	2,350 5,180	*2,980 *6,570	1,790 3,950	7.35 (24.1)
-1.5m -4.9ft		*9,110 *20,080	6,260 13,800	6,560 14,460	3,430 7,560	4,280 9,440	*3,530 *7,780	2,010 4,430	6.77 (22.2)
-3.0m -9.8ft									

5.0m (16' 5") 2-Piece boom, 2.6 m (8' 6") arm equipped with 4,200kg counter weight, dozer down.

Lift-point height m (ft)	Lift-point radius						At max. reach		
	3.0m (9.8ft)		4.5m (14.8ft)		6.0m (19.7ft)		Capacity	Reach	
	Over-front	Over-side	Over-front	Over-side	Over-front	Over-side	kg (lb)	m (ft)	
7.5m 24.6ft			*3,810 *8,400	*3,810 *8,400			*2,920 *6,440	*2,920 *6,440	5.15 (16.9)
6.0m 19.7ft			*3,660 *8,070	*3,660 *8,070	*3,740 *8,250	3,090 6,810	*2,510 *5,530	*2,510 *5,530	6.47 (21.2)
4.5m 14.8ft			*4,310 *9,500	*4,310 *9,500	*3,900 *8,600	3,030 6,680	*2,360 *5,200	2,190 4,830	7.24 (23.7)
3.0m 9.8ft			*5,480 *12,080	4,430 9,770	*4,390 *9,680	2,890 6,370	*2,360 *5,200	1,960 4,320	7.63 (25.0)
1.5m 4.9ft			*6,660 *14,680	4,090 9,020	4,420 9,740	2,740 6,040	*2,470 *5,450	1,890 4,170	7.71 (25.3)
0.0m 0.0ft			6,590 14,530	3,900 8,600	4,300 9,480	2,630 5,800	*2,730 *6,020	1,940 4,280	7.48 (24.5)
-1.5m -4.9ft		*8,140 *17,950	7,130 15,720	6,540 14,420	3,850 8,490	4,270 9,410	*3,240 *7,140	2,170 4,780	6.91 (22.7)
-3.0m -9.8ft									

5.0m (16' 5") 2-Piece boom, 2.6 m (8' 6") arm equipped with 4,200kg counter weight, dozer up.

Lift-point height m (ft)	Lift-point radius						At max. reach		
	3.0m (9.8ft)		4.5m (14.8ft)		6.0m (19.7ft)		Capacity	Reach	
	Over-front	Over-side	Over-front	Over-side	Over-front	Over-side	kg (lb)	m (ft)	
7.5m 24.6ft			*3,810 *8,400	*3,810 *8,400			*3,480 *7,670	*3,480 *7,670	5.15 (16.9)
6.0m 19.7ft			*3,660 *8,070	*3,660 *8,070	*3,740 *8,250	2,790 6,150	*2,990 *6,590	2,420 5,340	6.47 (21.2)
4.5m 14.8ft			*4,310 *9,500	*4,310 *9,500	*3,900 *8,600	2,740 6,040	*2,830 *6,240	1,970 4,340	7.24 (23.7)
3.0m 9.8ft			*5,480 *12,080	3,970 8,750	*4,390 *9,680	2,600 5,730	*2,820 *6,220	1,750 3,860	7.63 (25.0)
1.5m 4.9ft			*6,660 *14,680	3,640 8,020	4,420 9,740	2,450 5,400	*2,950 *6,500	1,680 3,700	7.71 (25.3)
0.0m 0.0ft			6,590 14,530	3,460 7,630	4,300 9,480	2,340 5,160	*3,150 *6,940	1,730 3,810	7.48 (24.5)
-1.5m -4.9ft		*8,880 *19,580	6,210 13,690	6,540 14,420	3,410 7,520	4,270 9,410	3,520 7,760	1,930 4,250	6.91 (22.7)
-3.0m -9.8ft									

- Lifting capacity are based on ISO 10567.
- Lifting capacity does not exceed 75% of tipping load with the machine on firm level ground or 87% of full hydraulic capacity.
- The Lift-point is bucket pivot mounting pin on the arm (without bucket mass).
- (*) indicates load limited by hydraulic capacity.

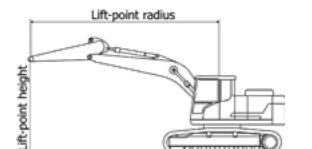

BUCKET SELECTION GUIDE & DIGGING FORCE

HW150A CR BUCKETS



SAE heaped m³ (yd³) ◆ 0.50 (0.65) ◆ 0.61 (0.80) 0.52 (0.68) 0.58 (0.76) 0.65 (0.85) 0.71 (0.93) ■ 0.45 (0.59) ◎ 0.55 (0.72)

Capacity m ³ (yd ³)		Width mm (in)		Weight kg (lb)	Tooth EA	Recommendation mm (ft.in)					
						3,250 kg CWT					
						4,600 (15' 1") Mono Boom			4,710 (2PCS) (15' 5") Mono Boom		
SAE heaped	CECE heaped	Without side cutters	With side cutters	2,000 (6' 7") Arm	2,450 (8' 0") Arm	2,600 (8' 6") Arm	2,000 (6' 7") Arm	2,450 (8' 0") Arm	2,600 (8' 6") Arm		
0.58 (0.76)	0.50 (0.65)	950 (37.4)	1,100 (43.7)	480 (1,060)	5	●	○	○	●	○	■
0.52 (0.68)	0.45 (0.59)	870 (34.3)	1,020 (40.2)	460 (1,010)	5	●	●	●	●	●	○
0.65 (0.85)	0.55 (0.72)	1,060 (41.7)	1,210 (47.6)	513 (1,130)	5	○	■	■	○	■	■
0.71 (0.93)	0.60 (0.78)	1,140 (44.9)	1,300 (51.2)	536 (1,180)	5	○	■	■	■	▲	▲
■ 0.45 (0.59)	0.40 (0.52)	1,520 (59.8)	1,520 (59.8)	410 (900)	0	●	●	●	●	●	●
◎ 0.55 (0.72)	0.45 (0.59)	1,800 (70.9)	1,800 (70.9)	585 (1,290)	0	●	○	○	●	○	■
◆ 0.50 (0.65)	0.45 (0.59)	762 (30.0)	821 (32.3)	439 (970)	4	●	●	●	●	●	●
◆ 0.61 (0.80)	0.54 (0.71)	914 (36.0)	974 (38.3)	490 (1,080)	5	●	○	○	○	■	■

- Heavy duty bucket
- ◎ Ditch cleaning bucket
- ◆ Hammerless tooth bucket

- : Applicable for materials with density of 2,100 kgf/m³ (3,500 lbf/yd³) or less
- : Applicable for materials with density of 1,800 kgf/m³ (3,000 lbf/yd³) or less
- : Applicable for materials with density of 1,500 kgf/m³ (2,500 lbf/yd³) or less
- ▲ : Applicable for materials with density of 1,200 kgf/m³ (2,000 lbf/yd³) or less
- : Not Recommended

HW170A CR BUCKETS

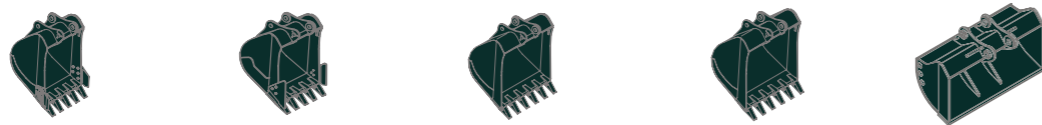

SAE heaped m³ (yd³) 0.70 (0.92) ◆ 0.73 (0.95) 0.89 (1.16) ■ 0.69 (0.90) ◎ 0.75 (0.90)

Capacity m ³ (yd ³)		Width mm (in)		Weight kg (lb)	Tooth EA	Recommendation mm (ft.in)		
						4,200 kg CWT		
						5,000 (16' 5") 2-Piece Boom		
SAE heaped	CECE heaped	Without Sidecutter	With Sidecutter	2,000 (6' 7") Arm	2,450 (8' 0") Arm	2,600 (8' 6") Arm		
0.70 (0.92)	0.60 (0.78)	1,020 (40.2")	1,100 (43.3")	600 (1,320)	5	○	■	■
0.76 (0.99)	0.65 (0.85)	1,090 (42.9")	1,170 (46.1")	620 (1,370)	5	■	▲	▲
0.89 (1.16)	0.77 (1.01)	1,250 (49.2")	1,325 (52.2")	680 (1,500)	6	▲	▲	-
■ 0.69 (0.90)	0.62 (0.81)	1,050 (41.3")	-	720 (1,590)	5	○	■	▲
◎ 0.75 (0.98)	0.65 (0.85)	1,760 (69.3")	-	540 (1,190)	0	○	■	■
◆ 0.73 (0.95)	0.67 (0.88)	914 (36.0")	946 (37.2")	620 (1,370)	5	○	■	▲
◆ 0.85 (1.11)	0.76 (0.99)	1,067 (42.0")	1,096 (43.1")	670 (1,480)	5	■	▲	▲

- Heavy duty bucket
- ◎ Ditch cleaning bucket
- ◆ Hammerless tooth bucket

- : Applicable for materials with density of 2,100 kgf/m³ (3,500 lbf/yd³) or less
- : Applicable for materials with density of 1,800 kgf/m³ (3,000 lbf/yd³) or less
- : Applicable for materials with density of 1,500 kgf/m³ (2,500 lbf/yd³) or less
- ▲ : Applicable for materials with density of 1,200 kgf/m³ (2,000 lbf/yd³) or less
- : Not Recommended

DIGGING FORCE

HW150A CR DIGGING FORCE

Boom	Length	mm (ft.in)	4,600 (15' 1") Mono			Remark
Arm	Length	mm (ft.in)	2,000 (6' 7")	2,450 (8' 0")	2,600 (8' 6")	
Bucket digging force	SAE	kN	87.8 [107]	87.9 [95.4]	87.9 [95.4]	[]: Power Boost
		kgf	8,956.9 [9720]	8,960.9 [9730]	8,960.9 [9730]	
		lbf	19,747 [21429]	19,755 [21451]	19,755 [21451]	
	ISO	kN	102.9 [111.7]	102.9 [111.7]	102.9 [111.7]	
		kgf	10,489.4 [11390]	10,494 [11390]	10,494 [11390]	
		lbf	23,125 [25111]	23,135 [25111]	23,135 [25111]	
Arm crowd force	SAE	kN	74.2 [80.6]	63.6 [69.0]	61.1 [66.3]	
		kgf	7,569.4 [8220]	6,485.2 [7040]	6,230.3 [6760]	
		lbf	16,688 [18122]	14,297 [15521]	13,735 [14903]	
	ISO	kN	77.9 [84.5]	66.3 [72.0]	63.6 [69.0]	
		kgf	7,942 [8620]	6,763.7 [7340]	6,485.9 [7040]	
		lbf	17,509 [19004]	14,911 [16182]	14,299 [15521]	

Boom	Length	mm (ft.in)	4,710 (15' 5") 2-Piece			Remark
Arm	Length	mm (ft.in)	2,000 (6' 7")	2,450 (8' 0")	2,600 (8' 6")	
Bucket digging force	SAE	kN	87.8 [95.3]	87.9 [95.4]	87.9 [95.4]	[]: Power Boost
		kgf	8,956.9 [9720]	8,960.9 [9730]	8,960.9 [9730]	
		lbf	19,747 [21429]	19,755 [21451]	19,755 [21451]	
	ISO	kN	102.9 [111.7]	102.9 [111.7]	102.9 [111.7]	
		kgf	10,489.4 [11390]	10,494 [11390]	10,494 [11390]	
		lbf	23,125 [25111]	23,135 [25111]	23,135 [25111]	
Arm crowd force	SAE	kN	74.2 [80.6]	63.6 [69.0]	61.1 [66.3]	
		kgf	7,569.4 [8220]	6,485.2 [7040]	6,230.3 [6760]	
		lbf	16,688 [18122]	14,297 [15521]	13,735 [14903]	
	ISO	kN	77.9 [84.5]	66.3 [72.0]	63.6 [69.0]	
		kgf	7,942 [8620]	6,763.7 [7340]	6,485.9 [7040]	
		lbf	17,509 [19004]	14,911 [16182]	14,299 [15521]	

Note : Arm weight includes bucket cylinder, linkage, and pin

HW170A CR DIGGING FORCE

Boom	Length	mm (ft.in)	5,000 (16' 5") 2-Piece			Remark
Arm	Length	mm (ft.in)	2,000 (6' 7")	2,450 (8' 0")	2,600 (8' 6")	
Bucket digging force	SAE	kN	98 [107]	98 [107]	98 [107]	[]: Power Boost
		kgf	10,008 [10,920]	9,992 [10,900]	10,026 [10,940]	
		lbf	22,060 [24,070]	22,030 [24,030]	22,100 [24,120]	
	ISO	kN	115 [125]	115 [125]	115 [126]	
		kgf	11,726 [12,790]	11,706 [12,770]	11,746 [12,810]	
		lbf	25,850 [28,200]	25,810 [28,150]	25,900 [28,240]	
Arm crowd force	SAE	kN	85 [93]	67 [73]	67 [73]	
		kgf	8,648 [9,430]	6,858 [7,480]	6,798 [7,420]	
		lbf	19,070 [20,790]	15,120 [16,490]	14,990 [16,360]	
	ISO	kN	89 [98]	70 [77]	70 [76]	
		kgf	9,118 [9,950]	7,178 [7,830]	7,106 [7,750]	
		lbf	20,100 [21,940]	15,830 [17,260]	15,670 [17,090]	

Note : Arm weight includes bucket cylinder, linkage, and pin

STANDARD / OPTION

ENGINE	STD	OPT
Cummins B 4.5 engine	●	
HYDRAULIC SYSTEM		
Advanced Load Sensing (LUDV)		
Power mode(P, S, E), Work mode(P, W, T), User mode	●	
Pressure Boost Function	●	
Attachment Flow Control	●	
3 attachment control modes (Push / Detent / Prop.)	●	
Engine Auto Idle	●	
Engine Auto Shutdown Control	●	
Electronic Fan Control	●	
20 km/h speed limit		●
35 km/h speed limit	●	
Hyundai Bio Hydraulic Oil (HBHO)		●
CAB & INTERIOR		
ISO Standard cabin		
Parallel type windshield wiper	●	
Radio / USB player	●	
Handsfree mobile phone system with USB	●	
12 volt power outlet (24V DC to 12V DC converter)	●	
Electric horn	●	
All-weather steel cab with 360° visibility	●	
Safety glass - Tempered glass with front laminated glass	●	
Safety glass windows	●	
Sliding fold-in front window	●	
Sliding side window(LH)	●	
Lockable door	●	
Hot & cool box	●	
Storage compartment	●	
Transparent cabin roof-cover	●	
Sun visor	●	
Door and cab locks, one key	●	
Pilot-operated slidable joystick	●	
Console box height adjust system	●	
Ashtray		●
Automatic climate control		
Air conditioner & heater	●	
Defroster	●	
Starting Aid (air grid heater) for cold weather	●	
Centralized monitoring		
8" LCD display	●	
Engine speed or Trip meter/Accel.		●
Engine coolant temperature gauge	●	
Max power	●	
Creep speed/Low speed/High speed	●	
Auto idle	●	
Overload warning with alarm	●	
Check Engine	●	
Air pre-cleaner		●
Air cleaner clogging	●	
ECO Gauges	●	
Fuel level gauge	●	
Hyd. oil temperature gauge	●	
Warnings	●	
Communication error indication	●	
Low battery	●	
Clock	●	
Cabin lights - Halogen		●
Cabin lights - LED		●
Cabin front window rain guard		●
Seat		
Mechanical Suspension with Heater	●	
Adjustable air suspension seat with heater		●
Operator Protective Structures		
General	●	
Wire Net	Front Guard	●
FOG (Falling Object Guard)	Front & Tops Guard	●
ISO 10262 Level 2	Top Guard	●
Cabin ROPS (ISO 12117-2)		
ROPS (Roll Over Protective Structure)	●	

MEMO

SAFETY	STD	OPT
2nd monitor		●
Battery master switch	●	
Rear view camera	●	
Rear & Mirror view camera		●
AAVM (Advanced Around View Monitoring)		●
Two working lights on Boom - Halogen	●	
Two working lights on Boom - LED		●
Travel alarm	●	
Rear work lamp		●
Beacon lamp		●
Automatic swing brake	●	
Safety lock valve for boom cylinder with overload warning device	●	
Safety lock valve for arm cylinder	●	
Swing Lock System		●
Four outside rearview mirror	●	
ATTACHMENT		
HW150A CR Booms		
4.60 m, 15' 1" Mono	●	
4.71 m, 15' 2" 2-Piece		●
HW170A CR Booms		
5.0 m, 16' 5" 2-Piece		
Arms		
2.00 m, 6' 7"		●
2.45 m, 8' 0"	●	
2.60 m, 8' 6"		●
2.45 m, w/o reinf		●
2.60 m, w/o reinf		●
OTHER		
Removable clean-out dust net for cooler	●	
Fuel pre-filter	●	
Self-diagnostics system	●	
Hi MATE (Remote Management System)	Mobile Satellite	●
Batteries (2 x 12V x 100 AH)	●	
Fuel filler pump (35 lpm)		●
Bucket line 3way		●
Single-acting piping kit (breaker, etc.)		●
Double-acting piping kit (clamshell, etc.)		●
Rotating Piping Kit		●
Quick coupler piping		●
Quick coupler		●
Accumulator for lowering work equipment	●	
Pattern change valve (2 patterns)		●
Fine Swing Control System		●
Ride control & Boom floating		●
Automatic digging brake		●
Joystick Steering		●
Tool kit		●
Auto cruiser system	●	
Lower Frame Toolbox - LH		
Lower Frame Toolbox - LH, RH		●
UNDERCARRIAGE		
Rear dozer blade	●	
Rear outrigger		●
Front outrigger and rear blade		●
Front blade and rear outrigger		●
Front and rear outrigger		●
Front and rear blade		●
Front grapple rest and rear blade		●
Front grapple rest and rear outrigger		●
Front bucket rest and rear blade		●
Front bucket rest and rear outrigger		●
Tires-dual (10.00-20-14PR tube)	●	
Tires-dual (10.00-20-16PR tube)		●
Tires-dual (10.00-20 solid)		●
Trailer hitch for rear dozer blade		●
Wheel Chock		●
Fenders (Mudguards) - General axle		●
Fenders (Mudguards) - Wide axle (HW170A CR Only)		●
General axle 2.5m	●	
Wide axle 2.7 m (HW170A CR Only)		●

* Standard and optional equipment may vary. Contact your Hyundai dealer for more information.
 The machine may vary according to International standards.
 * The photos may include attachments and optional equipment that are not available in your area.
 * Materials and specifications are subject to change without advance notice.
 * All imperial measurements rounded off to the nearest pound or inch.