



# R130S

## Standard Equipment

### ISO standard cabin

- All-weather steel cab with all-around visibility
- Safety glass windows
- Rise-up type windshield wiper
- Sliding fold-in front window
- Sliding side window
- Lockable door
- Accessory box & Ashtray

### Computer Aided Power Optimization (New CAPO) system

- 3-power mode, 2-work mode
- One touch deceleration system
- Auto deceleration system
- Auto overheat prevention system

### Self diagnostic system Centralized monitoring

- LCD display
- Engine speed
- Clock & Error code
- Gauges
- Fuel level gauge
- Engine coolant temperature gauge
- Hydraulic oil temperature gauge
- Warning
- Fuel level
- CPU
- Engine oil pressure
- Engine coolant temperature
- Hydraulic oil temperature
- Low battery
- Air cleaner clogging
- Indicator
- One touch decel

### Tool kit

- Door and cab locks, one key
- One outside rearview mirror
- Fully adjustable suspension seat
- Slidable joystick, pilot-operated
- 2 front working lights
- Electric horn
- Batteries (2 x 12V x 72 AH)
- Battery master switch
- Removable clean out screen for oil cooler
- Automatic swing brake
- Removable reservoir tank
- Fuel pre-filter
- Boom holding system
- Arm holding system
- Counterweight (1,600kg, 3,527lb)
- Mono boom (4.3m, 14' 1")
- Arm (2.26m, 7' 5")
- Standard bucket (0.45m<sup>3</sup>, 0.59yd<sup>3</sup>)
- Track shoes (500mm)
- Track rail guard
- Operator kit
- Radio/USB Play

## Optional Equipment

- Air-conditioner (5,000 kcal/hr, 20,000 BTU/hr)
- Sun visor for cabin inside
- Beacon lamp
- Single acting piping kit (breaker, etc)
- 12 volt power outlet (24V DC to 12V DC converter)
- Various optional arms
- Arm (1.96m, 6'5")

### Various optional buckets (SAE heaped)

- Bucket(0.65m<sup>3</sup>, 0.85yd<sup>3</sup>)

### Track shoes

- Triple grouser shoe (600 mm, 24")

### Cabin front protector

- Travel Alarm
- Fuel Filler Pump
- Hi MATE(Remote Management System)

\* Standard and optional equipment may vary. Contact your Hyundai dealer for more information.  
The machine shown may vary according to International standards. All US measurement rounded off to nearest pounds or inches.



Head Office(Sales Office)  
14F, GLOBAL R&D CENTER, 477 BUNDANG SUSEO-RO, BUNDANG-GU, SEONGNAM-SI, GYEONGGI-DO, 13553, KOREA

PLEASE CONTACT

# R130S

\* Photo may include optional equipment.



Engine Rated Power  
94 HP (70.1 kW) @1,950 rpm

Bucket Capacity  
0.45 / 0.65m<sup>3</sup>

Operating Weight  
12,100kg

# HYUNDAI

# BUILT FOR MAXIMUM POWER, PERFORMANCE AND RELIABILITY

A new chapter in construction equipment has begun.

## OPERATOR COMFORT



Ergonomically placed operator controls with spacious AC cabin & fully adjustable seat provides perfect working environment and reduces operator fatigue in long working hours.



## IMPROVED FUEL EFFICIENCY

Upgraded circuit design, added sensor controls & advanced hydraulics for variable load sensing have been designed for improved fuel efficiency.

## BETTER VISIBILITY



Cabin roof lights provide enhanced visibility and enable the operator to work at night with ease.

## BEST-IN CLASS PERFORMANCE



Hyundai's advanced CAPO technology added with hydraulic flow summation and regeneration ensures faster cycle time, additional bucket link reinforcement to support excellent bucket dig and arm crowd forces.

## INCREASED MACHINE DURABILITY



Idler area track reinforcement with heavy duty applications.

## NEW GENERATION STYLING



All new aesthetics with dual tone color.



# PERFORMANCE

R130S is designed for maximum performance to keep the operator working productivity.



## ENGINE

The 94 HP, Hyundai HM4.2 engine is built for power, reliability, efficiency and reduced emissions. The engine is manufactured to perform in wide range of heat, humidity and dust conditions without compromising productivity.

## HYDRAULICS

Hydraulic pump instilled in Hyundai is variable displacement axial piston type with electro hydraulic control function. This system provides wide range of flow at various workloads for paramount productivity. Open center design of Main Control Valve (MCV) with port relief valves & spools ensures fast response and maximum efficiency in extreme conditions. Travel & swing motor speeds provide excellent mobility for improved cycle time.

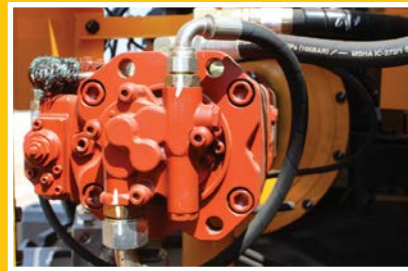

## SWING PRIORITY

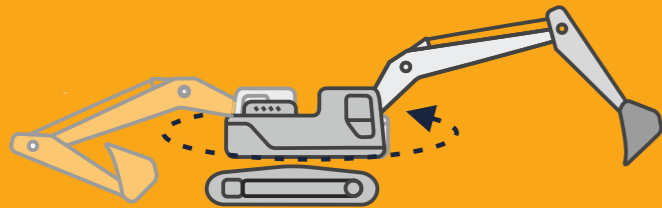

Swing priority spool is auto piloted which boosts higher hydraulic energy to swing circuitry. This leads to faster swing cycle which in turn results in more output & better performance.

## ARM REGENERATION

Arm regeneration system helps to recirculate hydraulic energy from return line and adds to pump supply line. It provides smooth operation of arm preventing cavitation and increasing performance of machine.

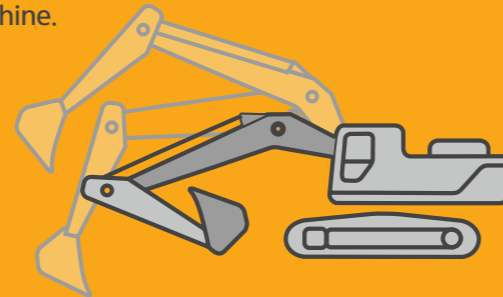

## NEGATIVE FLOW CONTROL



Pump flow is proportionally regulated with control lever stroke which saves fuel by regulating pump and engine. It maintains higher standby pressure for faster response and continuous oil flow for even temperature.

# PREFERENCE

Operating R130S is unique to every operator. Operators can fully customize their work environment.

## OPERATOR CONVENIENCE

You can easily adjust the seat, console and armrest settings to best suit your preferred comfort level. Spacious cabin with other preference settings that creates a higher grade working environment and reduces fatigue include the high capacity air conditioning system, and radio/USB player. Additional cabin lights as standard attachment enhances visibility while doing work at night time. Added distribution of air flow through front and rear aircon ducting facilitates increased airflow distribution inside the cabin which in turn ensures operator comfort to increase operator efficiency and capacity to improve production.



## FUEL FILLER PUMP



Optional fuel filler pump enables refueling of fuel tank ensuring clean fuel to the engine which in turn avoids fuel contamination from atmospheric air. Also, the time required to refill is reduced to ensure higher uptime for more productivity.

## EXTENDED MAINTENANCE INTERVAL



R130S is designed with long-life hydraulic filters up to 1,000 hrs, long-life hydraulic oil up to 5,000 hrs, more efficient cooling systems which extend service intervals, minimizing operating costs and reduce machine down time.

## EASY ACCESS & SERVICEABILITY

Easy access for maintenance means regular checks get done faster, giving you more uptime. Hyundai's SMART machines feature easy service access to increase uptime and keep maintenance to a minimum to reduce operating costs.



## Hi MATE (Remote Management System)

Hi MATE, Hyundai's proprietary remote management system, provides operators and dealer service personnel access to vital service and diagnostic information on the machine from any computer with internet access. Users can pinpoint machine location using digital mapping and set machine work boundaries, reducing the need for multiple service calls. Hi MATE saves time and money for the owner and dealer by promoting preventative maintenance and reducing machine downtime.

# PRECISION

Innovative hydraulic system technologies make R130S fast, smooth and easy to control.

## COMPUTER AIDED POWER OPTIMIZATION

The engine horsepower and hydraulic horsepower together in unison through the advanced CAPO (Computer Aided Power Optimization) system, flow for the job at hand. Operator can set their own preferences for boom or swing priority, power mode selection and optional work tools at the touch of a button.

The CAPO system also provides complete self-diagnostic features and digital gauges for important information like hydraulic oil temperature, coolant temperatures and fuel level. This system interfaces with multiple sensors placed throughout the hydraulic system as well as engine to provide the optimum level of engine power and hydraulic flow.

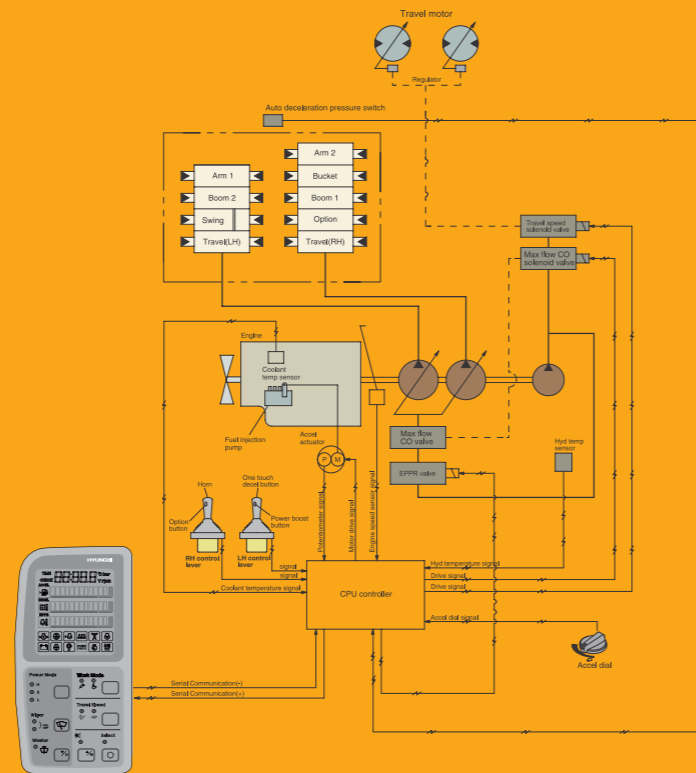

## DISPLAY CLUSTER

The instrument panel is installed in front of RH console box, making it easy to check all critical systems like hydraulic oil temperature, water and fuel temperature via easy-to-read indicators. Using a keypad you can make quick visual and diagnostic checks, increasing uptime and productivity.

Hyundai unique system offers wide range of mode options to choose from.

This helps in optimizing machine performance for various level of productivity needs ensuring fuel efficiency.



POWER MODE	H (High Power) Mode maximizes machine speed & power for mass production. S (Standard) Mode provides a reduced, fixed RPM for optimum performance & improved fuel economy L (Light Power) Mode optimizes the engine performance corresponding to the lighter work conditions.
WORK MODE	It allows the operator to select single flow attachments like bucket & breaker



## ONE TOUCH DECELERATION

One touch deceleration switch on top of LH joystick lowers the engine RPM when selected. Engine speed is recovered to its preselected RPM when it is selected again. This system saves fuel by regulating pump and engine.

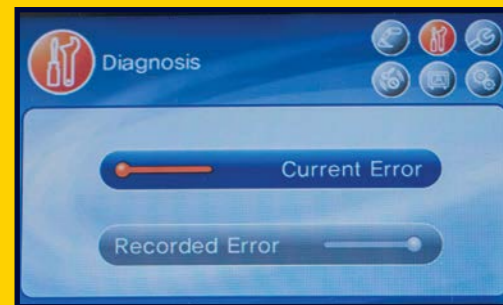

## SELF-DIAGNOSTICS SYSTEM

The MCU diagnoses problems in the CAPO system caused by machine malfunctions and displays the same on the cluster LCD monitor as error codes. The information via this device which includes engine rpm, main pump delivery pressure, battery voltage, hydraulic temperature and the status of electric switches allows the operator to know exact operating conditions of the machine. This makes it easier to troubleshoot any problems that occur.



## MAINTENANCE MANAGEMENT

This smart feature keeps a record of scheduled time interval for each maintenance area. It also keeps a real time update of the time duration left for the next scheduled maintenance for each and every maintenance area. This feature ensures maintenance of the machine by keeping the operator updated at all times.

## L MODE & MAX FLOW CUT OFF



L (Light Power) Mode adjusts engine power and hydraulic torque for optimum performance at improved fuel economy.

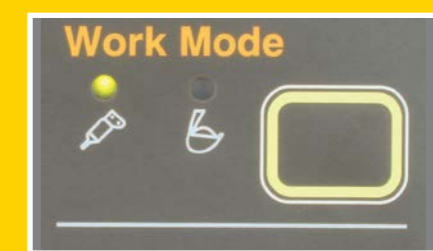

Max flow cut off system reduces pump flow for precise control during breaker use to ensure reduction in energy wastage.

# RELIABILITY

The robust frame structure and the attachments promise higher productivity.

## IDLER AREA REINFORCEMENT

Added reinforcement in idler area ensures machine durability in challenging environments and contribute towards a well-balanced & solid machine while operating in adverse terrains.



## BUCKET LINK REINFORCEMENT

Bucket link reinforcement supports excellent bucket dig and arm crowd forces.



## ATTACHMENTS - BUCKET

**GP Bucket** – Features high tensile strength steel with internal reinforcements. It is specially designed for light duty to moderate applications like earthwork and loading.



## STRUCTURE

The reinforced upper structure and lower frame are built to withstand tougher conditions for improved durability & reliability.



# NEW GENERATION STYLING AND SAFETY

Hyundai's R130S comes with stylish decals & unique dual tone counter weight & cabin making it peppier than ever before. And with that stylish dual tone look you can have a machine that's eye catching too.



## SAFETY - MORE THAN A PEACE OF MIND. TOTAL CONFIDENCE

Cabin is integrally welded with low-stress using high strength steel to provide enhanced protection. Handrails and steps are provided for easy operation. Anti-slip pads provide safety against skidding while operating machine.



- Auto engine overheat prevention function monitors coolant temperature & if high temperature is detected, the CPU controller automatically lowers the engine speed and hence cooling down the engine.
- Anti-restart system prevents starter from restarting during engine operation even if operator accidentally turns on start key again.
- Safety lever ensures safeguarding against machine movements by preventing hydraulic functions of machine until it is released.
- Counterbalance works as a hydrostatic brake and prevents machine against accidental roll down in steep gradients.
- Holding valve prevent attachments from drifting against gravity due to prolonged overhanging.

# SPECIFICATIONS

## ENGINE

MODEL	HYUNDAI HM4.2		
TYPE	Water Cooled, 4cylinder in line, direct injection turbocharged.		
Rated fly-wheel horse power	SAE	J1995 (gross)	94 HP (70.1 kW) @ 1,950 rpm
		J1349 (net)	91 HP (67.9 kW) @ 1,950 rpm
	DIN	6271/1 (gross)	95 PS (70.1 kW) @ 1,950 rpm
		6271/1 (net)	92 PS (67.9 kW) @ 1,950 rpm
Max. Torque	36.5 kgf.m (264 lbf.ft) @ 1,550 rpm		
Bore x stroke	105x120 mm		
Piston Displacement	4,160 cc		
Battery	2x12 V x 80Ah		
Starting Motor	24 V-4.7 kW		
Alternator	24V-55A		

## HYDRAULIC SYSTEM

### MAIN PUMP

Type	Two variable displacement piston pumps
Max. flow	2 x 112 lpm (29.6 US gpm/24.6 UK gpm)
Sub-pump for pilot circuit	Gear pump
Cross-sensing & fuel saving pump system	

### HYDRAULIC MOTORS

Travel	Two speed axial piston motor with counter balance valve and parking brake
Swing	Axial piston motor with automatic brake

### RELIEF VALVE SETTINGS

Implement circuits	330 kgf/cm <sup>2</sup> (4,690 psi)
Travel	330 kgf/cm <sup>2</sup> (4,690 psi)
Swing circuit	240 kgf/cm <sup>2</sup> (3,410 psi)
Pilot circuit	35 kgf/cm <sup>2</sup> (498 psi)
Service valve	Installed

### HYDRAULIC CYLINDERS

No. of cylinder - bore x rod x stroke	Boom: 2-95 x 70 x 1,015 mm (3.7"x 2.7"x 40.0")
	Arm: 1-110 x 75 x 1,070 mm (4.3"x 3.0" x 42.1")
	Bucket: 1-95 x 65 x 855 mm (3.7"x 2.6"x 33.7")

## DRIVE & BRAKES

Drive method	Fully hydrostatic type
Drive motor	Axial piston motor, in-shoe design
Reduction system	Planetary reduction gear
Max. drawbar pull	10,400 kgf (22,930 lbf)
Drive motor	5.5 kmph (3.4mph) / 3.4 kmph (2.1mph)
Reduction system	35° (70%)
Reduction system	Multi wet disc

## CONTROL

Pilot pressure operated joysticks and pedals with detachable lever provide almost effortless and fatigueless operation.

Pilot control	Two joysticks with one safety lever (LH): Swing and arm, (RH): Boom and bucket (ISO)
Traveling and steering	Two levers with pedals
Engine throttle	Electric, Dial type
External Lights	1 x Boom, 1 x Toolbox, 2 x Cabin

## SWING SYSTEM

### MAIN PUMP

Swing motor	Axial piston motor
Swing reduction	Planetary gear reduction
Swing bearing lubrication	Grease bathed
Swing brake	Multi wet disc
Swing speed	12 rpm

## COOLANT & LUBRICANT CAPACITY

REFILLING	LITER
Fuel tank	250
Engine coolant	20
Engine oil	11.5
Swing device	2.5
Final drive (each)	2.5
Hydraulic system (Including tank )	180
Final drive (each)	100

## UNDERCARRIAGE

The X-leg type center frame is integrally welded with reinforced box-section track frames. The undercarriage includes lubricated rollers, idlers, track adjusters with shock absorbing springs and sprockets and track chain with triple grouser shoes.

Center frame	X -leg type
Track frame	Pentagonal box type
No. of shoes on each side	41
No. of carrier roller on each side	1
No. of track roller on each side	6
No. of rail guard on each side	1

## OPERATING WEIGHT (APPROXIMATE)

Operating weight, including 4,300mm (14' 1") boom, 2,260mm(7' 5") arm, SAE heaped 0.45m<sup>3</sup>(0.59yd<sup>3</sup>) backhoe bucket, lubricant, coolant, fuel tank, hydraulic tank, operator and the standard equipment.

### MAJOR COMPONENT WEIGHT

Upper structure	3,300kg (7,280lb)
Counter weight	1,600kg (3,527lb)
Boom (with arm cylinder)	950kg (2,090lb)

### OPERATING WEIGHT

Shoes	Operating weight	Ground pressure
Counter weight	Width mm (in) kg (lb)	kgf/cm <sup>2</sup> (psi)
Triple grouser	*500 mm (20") 12,100(26,675)	0.42(5.98)

\* Standard equipment

## BUCKETS

All buckets are welded with high-strength steel.

### TYPES OF BUCKETS

SAE heaped

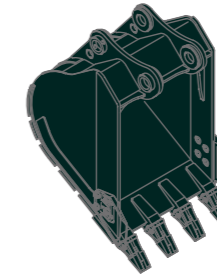

\*0.45 m<sup>3</sup> (0.59yd<sup>3</sup>)

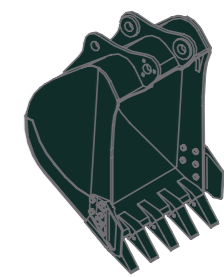

0.65 m<sup>3</sup> (0.85 yd<sup>3</sup>)

Type	Capacity m <sup>3</sup> (yd <sup>3</sup> )		Width mm (in)		Weight kg (lb)	Recommendation mm (ft.in)	
	SAE heaped	CECE heaped	Without side cutters	With side cutters		*4,300 (14' 1") Boom	
GP	*0.45 (0.59)	0.40 (0.52)	830 (32.7)	940 (37.0)	430 (950)	1,960 (6' 5") Arm	*2,260 (7' 5") Arm
	0.65 (0.85)	0.52 (0.68)	1,020 (40.2)	1,130 (44.5)	531 (1170)	●	●

\* Standard bucket

- Applicable for materials with density of 2,000 kg /m<sup>3</sup> (3,370 lb/ yd<sup>3</sup>) or less
- Applicable for materials with density of 1,600 kg /m<sup>3</sup> (2,700 lb/ yd<sup>3</sup>) or less
- ▲ Applicable for materials with density of 1,100 kg /m<sup>3</sup> (1,850 lb/ yd<sup>3</sup>) or less
- x Not Recommended

## ATTACHMENT

Booms and arms are welded with a low-stress, full-box section design. 4,300 mm (14' 4") mono boom and 1,960 mm (6' 5"), 2,260 mm (7' 5") arms are available. Buckets are all-welded, high-strength steel implements.



1,960 mm (6' 5")



\*2,260 mm (7' 5")

Arm	Length	Weight	mm (ft.in)		
			1,960 (6' 5")	*2,260 (7' 5")	
Bucket digging force	SAE	kN	78.5	78.5	
			kgf	8,000	8,000
				lbf	17,640
	ISO	kN	90.2	90.2	
			kgf	9,200	9,200
				lbf	20,280
Arm crowd force	SAE	kN	60.2	55.7	
			kgf	6,140	5,680
				lbf	13,540
	ISO	kN	62.9	58.1	
			kgf	6,410	5,920
				lbf	14,130

\* Standard arm

# DIMENSIONS & WORKING RANGES

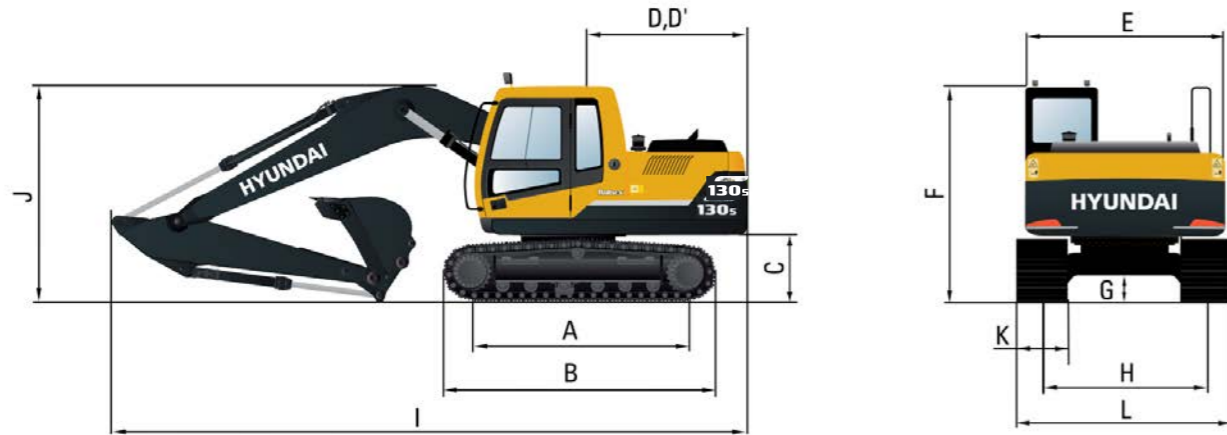

DIMENSIONS	mm (ft.in)
A Tumbler distance	2,610 (8' 7")
B Overall length of crawler	3,340 (10' 11")
C Ground clearance of counterweight	900 (2' 11")
D Tail Swing Radius	2,130 (7' 0")
D' Rear-end length	2,110 (6' 11")
E Overall width of upperstructure	2,475 (8' 1")
F Overall height of cab	2,800 (9' 2")
G Min. ground clearance	440 (1' 5")
H Track gauge	1,990 (6' 6")

DIMENSIONS	mm (ft.in)	
Boom length	*4,300 (14' 1")	
Arm length	1,960 (6' 5")	*2,260 (7' 5")
I Overall length	7,240 (23' 9")	7,270 (23' 10")
J Overall height of boom	2,550 (8' 4")	2,720 (8' 11")
K Track shoe width	*500 (20")	600 (24")
L Overall width	2,490 (8' 2")	2,590 (8' 6")

\* Standard equipment

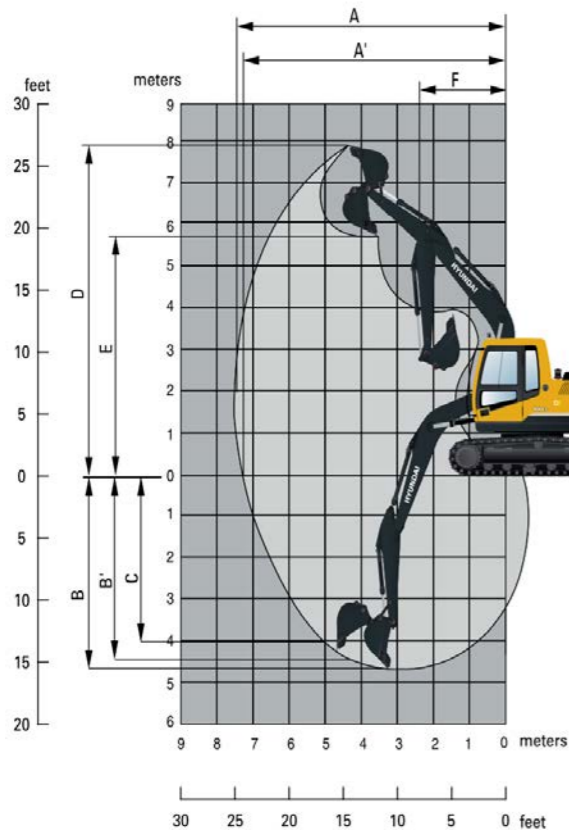

DIMENSIONS	mm (ft.in)	
Boom length	*4,300 (14' 1")	
Arm length	1,960 (6' 5")	*2,260 (7' 5")
A Maximum digging reach	7,460 (24' 6")	7,740 (25' 5")
A' Maximum digging reach on ground	7,320 (24' 0")	7,610 (25' 0")
B Maximum digging depth	4,770 (15' 8")	5,090 (16' 8")
B' Maximum digging depth (8' level)	4,510 (14' 10")	4,870 (16' 0")
C Maximum vertical digging depth	4,070 (13' 4")	4,430 (14' 6")
D Maximum digging height	7,900 (25' 11")	8,070 (26' 6")
E Maximum dumping height	5,540 (18' 2")	5,710 (18' 9")
F Minimum swing radius	2,340 (7' 8")	2,380 (7' 10")

\* Standard equipment

# LIFTING CAPACITIES

## LIFTING CAPACITIES R130S SMART

Rating over-front Rating over-side or 360 degree

		Boom: 4.3 m (14' 1") / Arm: 2.26 m (7' 5") / Shoe: 500mm (20") triple grouser										
Lift point height m (ft)		Lift point radius								At max. reach		
		1.5 m (4.9 ft)		3.0 m (9.8 ft)		4.5 m (14.8 ft)		6.0 m (19.7 ft)		Capacity	Reach	
												m (ft)
6.0 m (19.7 ft)	kg					*2,750	*2,750			*2,390	*2,390	4.61
	lb					*6,060	*6,060			*5,270	*5,270	(15.1)
4.5 m (14.8 ft)	kg					*2,730	*2,730			*2,130	1,920	5.76
	lb					*6,020	*6,020			*4,700	4,230	(18.9)
3.0 m (9.8 ft)	kg			*4,250	*4,250	*3,280	2,780	2,250	1,760	2,050	1,600	6.35
	lb			*9,370	*9,370	*7,230	6,130	4,960	3,880	4,520	3,530	(20.8)
1.5 m (4.9 ft)	kg			*6,400	4,750	3,390	2,600	2,180	1,690	1,910	1,480	6.54
	lb			*14,110	10,470	7,470	5,730	4,810	3,730	4,210	3,260	(21.5)
Ground	kg			6,240	4,490	3,240	2,460	2,130	1,640	1,950	1,500	6.38
Line	lb			13,760	9,900	7,140	5,420	4,700	3,620	4,300	3,310	(20.9)
-1.5 m (-4.9 ft)	kg	*4,670	*4,670	6,200	4,460	3,190	2,410			2,210	1,700	5.83
	lb	*10,300	*10,300	13,670	9,830	7,030	5,310			4,870	3,750	(19.1)
-3.0 m (-9.8 ft)	kg	*8,950	*8,950	*6,270	4,560	3,250	2,470			3,010	2,300	4.75
	lb	*19,730	*19,730	*13,820	10,050	7,170	5,450			6,640	5,070	(15.6)



		Boom: 4.3 m (14' 1") / Arm: 2.26 m (7' 5") / Shoe: 600mm (24") triple grouser										
Lift point height m (ft)		Lift point radius								At max. reach		
		1.5 m (4.9 ft)		3.0 m (9.8 ft)		4.5 m (14.8 ft)		6.0 m (19.7 ft)		Capacity	Reach	
												m (ft)
6.0 m (19.7 ft)	kg					*2,750	*2,750			*2,390	*2,390	4.61
	lb					*6,060	*6,060			*5,270	*5,270	(15.1)
4.5 m (14.8 ft)	kg					*2,730	*2,730			*2,130	1,970	5.76
	lb					*6,020	*6,020			*4,700	4,340	(18.9)
3.0 m (9.8 ft)	kg			*4,250	*4,250	*3,280	2,850	2,320	1,810	*2,090	1,640	6.35
	lb			*9,370	*9,370	*7,230	6,280	5,110	3,990	*4,610	3,620	(20.8)
1.5 m (4.9 ft)	kg			*6,400	4,880	3,480	2,670	2,250	1,740	1,970	1,520	6.54
	lb			*14,110	10,760	7,670	5,890	4,960	3,840	4,340	3,350	(21.5)
Ground	kg			6,410	4,610	3,330	2,530	2,190	1,690	2,000	1,550	6.38
Line	lb			14,130	10,160	7,340	5,580	4,830	3,730	4,410	3,420	(20.9)
-1.5 m (-4.9 ft)	kg	*4,670	*4,670	6,380	4,580	3,280	2,490			2,270	1,750	5.83
	lb	*10,300	*10,300	14,070	10,100	7,230	5,490			5,000	3,860	(19.1)
-3.0 m (-9.8 ft)	kg	*8,950	*8,950	*6,270	4,680	3,350	2,540			3,100	2,370	4.75
	lb	*19,730	*19,730	*13,820	10,320	7,390	5,600			6,830	5,220	(15.6)

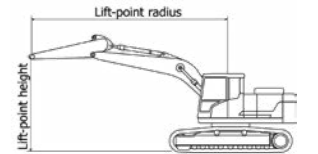









- Lifting capacity is based on SAE J1097, ISO 10567.
- Lifting capacity of the Robex Series does not exceed 75% of the tipping load with the machine on firm, level ground or 87% of full hydraulic capacity.
- The Lift-point is bucket pivot mounting pin on the arm (without bucket mass).
- \*Indicates the load limited by hydraulic capacity.













# LIFTING CAPACITIES

## LIFTING CAPACITIES R130S SMART

 Rating over-front    
  Rating over-side or 360 degree

Boom: 4.3 m (14' 1") / Arm: 1.96 m (6' 5") / Shoe: 500mm (20") triple grouser												
Lift point height m (ft)	Lift point radius								At max. reach			
	1.5 m (4.9 ft)		3.0 m (9.8 ft)		4.5 m (14.8 ft)		6.0 m (19.7 ft)		Capacity		Reach m (ft)	
												
6.0 m (19.7 ft)	kg									*2,660	*2,660	4.20
	lb									*5,860	*5,860	(13.8)
4.5 m (14.8 ft)	kg					*2,970	2,880			*2,330	2,090	5.43
	lb					*6,550	6,350			*5,140	4,610	(17.8)
3.0 m (9.8 ft)	kg			*4,710	*4,710	*3,490	2,750	2,230	1,740	2,190	1,710	6.06
	lb			*10,380	*10,380	*7,690	6,060	4,920	3,840	4,830	3,770	(19.9)
1.5 m (4.9 ft)	kg			6,430	4,660	3,360	2,570	2,170	1,680	2,030	1,580	6.26
	lb			14,180	10,270	7,410	5,670	4,780	3,700	4,480	3,480	(20.5)
Ground Line	kg			6,220	4,470	3,230	2,450	2,130	1,640	2,080	1,610	6.09
	lb			13,710	9,850	7,120	5,400	4,700	3,620	4,590	3,550	(20.0)
-1.5 m (-4.9 ft)	kg	*5,120	*5,120	6,220	4,470	3,200	2,420			2,400	1,840	5.51
	lb	*11,290	*11,290	13,710	9,850	7,050	5,340			5,290	4,060	(18.1)
-3.0 m (-9.8 ft)	kg			*5,890	4,600					3,460	2,640	4.36
	lb			*12,990	10,140					7,630	5,820	(14.3)

Boom: 4.3 m (14' 1") / Arm: 1.96 m (6' 5") / Shoe: 600mm (24") triple grouser												
Lift point height m (ft)	Lift point radius								At max. reach			
	1.5 m (4.9 ft)		3.0 m (9.8 ft)		4.5 m (14.8 ft)		6.0 m (19.7 ft)		Capacity		Reach m (ft)	
												
6.0 m (19.7 ft)	kg									*2,660	*2,660	4.20
	lb									*5,860	*5,860	(13.8)
4.5 m (14.8 ft)	kg					*2,970	2,950			*2,330	2,140	5.43
	lb					*6,550	6,500			*5,140	4,720	(17.8)
3.0 m (9.8 ft)	kg			*4,710	*4,710	*3,490	2,820	2,290	1,790	2,260	1,760	6.06
	lb			*10,380	*10,380	*7,690	6,220	5,050	3,950	4,980	3,880	(19.9)
1.5 m (4.9 ft)	kg			6,610	4,790	3,450	2,640	2,240	1,730	2,090	1,620	6.26
	lb			14,570	10,560	7,610	5,820	4,940	3,810	4,610	3,570	(20.5)
Ground Line	kg			6,390	4,600	3,320	2,520	2,190	1,690	2,140	1,650	6.09
	lb			14,090	10,140	7,320	5,560	4,830	3,730	4,720	3,640	(20.0)
-1.5 m (-4.9 ft)	kg	*5,120	*5,120	6,400	4,600	3,290	2,490			2,470	1,900	5.51
	lb	*11,290	*11,290	14,110	10,140	7,250	5,490			5,450	4,190	(18.1)
-3.0 m (-9.8 ft)	kg			*5,890	4,730					3,560	2,710	4.36
	lb			*12,990	10,430					7,850	5,970	(14.3)

- Lifting capacity is based on SAE J1097, ISO 10567.
- Lifting capacity of the Robex Series does not exceed 75% of the tipping load with the machine on firm, level ground or 87% of full hydraulic capacity.
- The Lift-point is bucket pivot mounting pin on the arm (without bucket mass).
- \*Indicates the load limited by hydraulic capacity.

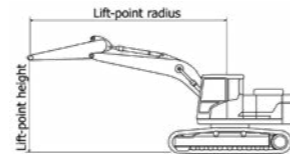

# R130S



\*Photo may include optional equipment.