

ENGINE	STD	OPT
Perkins / 1204F-E44TAN	●	
HYDRAULIC SYSTEM		
Intelligent Power Control (IPC)		
3-power mode, 2-work mode, user mode	●	
Variable Power Control	●	
Pump Flow Control	●	
Attachment Mode Flow Control		●
Engine Auto Idle	●	
Engine Auto Shutdown Control	●	
Electronic Fan Control	●	
CAB & INTERIOR		
ISO Standard cabin		
Rise-up type windshield wiper	●	
Radio / USB player	●	
Handsfree mobile phone system with USB	●	
12 volt power outlet (24V DC to 12V DC converter)	●	
Electric horn	●	
All-weather steel cab with 360° visibility	●	
Safety glass - Tempered glass	●	
Safety glass - Tempered glass with front laminated glass		●
Sliding fold-in front window	●	
Sliding side window(LH)	●	
Lockable door	●	
Hot & cool box	●	
Storage compartment & Ashtray	●	
Transparent cabin roof-cover	●	
Sun visor	●	
Door and cab locks, one key	●	
Mechanical suspension seat with heater	●	
Pilot-operated slidable joystick	●	
Console box height adjust system	●	
Automatic climate control		
Air conditioner & heater	●	
Defroster	●	
Starting Aid (air grid heater) for cold weather	●	
Centralized monitoring		
8" LCD display	●	
Engine speed or Trip meter/Accel.	●	
Engine coolant temperature gauge	●	
Max power	●	
Low speed/High speed	●	
Auto idle	●	
Overload warning with alarm		●
Check Engine	●	
Air cleaner clogging	●	
Indicators	●	
ECO Gauges	●	
Fuel level gauge	●	
Hyd. oil temperature gauge	●	
Fuel warmer	●	
Warnings	●	
Communication error	●	
Low battery	●	
Clock	●	
Cabin lights		●
Cabin front window rain guard		●
Cabin roof-steel cover		●
Seat		
Adjustable air suspension seat with heater		●
Cabin FOPS		
FOPS(Falling Object Protective Structure) ISO 10262 Level 2	Front & Top Guard	●
	Top Guard	●
Cabin ROPS		
ROPS (Roll Over Protective Structures) - ISO 12117-2		●

SAFETY	STD	OPT
Battery master switch	●	
Rearview camera		●
AAVM (Advanced Around View Monitoring)		●
Four front working lights (2 boom mounted, 2 front frame mounted)	●	
Travel alarm		●
Rear work lamp		●
Beacon lamp		●
Automatic swing brake	●	
Boom holding system	●	
Arm holding system	●	
Safety lock valve for boom cylinder with overload warning device		●
Safety lock valve for arm cylinder		●
Swing Lock System		●
Three outside rearview mirror	●	
OTHER		
Booms		
4.6 m, 15' 1"	●	
4.1 m, 13' 5"		●
4.9 m, 16' 1" 2-Piece boom		●
Arms		
1.9 m, 6' 3"		●
2.1 m, 6' 11"		●
2.5 m, 8' 2"	●	
3.0 m, 9' 10"		●
Removable clean-out dust net for cooler	●	
Removable reservoir tank	●	
Fuel pre-filter	●	
Fuel warmer		●
Self-diagnostics system	●	
Hi MATE (Remote Management System)	Mobile	●
	Satellite	●
Batteries (2 x 12V x 100 AH)	●	
Fuel filler pump (20 L/min)		●
Single-acting piping kit (breaker, etc.)		●
Double-acting piping kit (clamshell, etc.)		●
Rotating Piping Kit		●
Quick coupler piping		●
Quick coupler		●
Boom floating control		●
Accumulator for lowering work equipment	●	
Pattern change valve (2 patterns)		●
Fine Swing Control System		●
Tool kit		●
UNDERCARRIAGE		
Lower frame under cover (Additional)		●
Lower frame under cover (Normal)	●	
Dozer blade		●
Track shoes		
Triple grousers shoes (600mm, 24")	●	
Triple grousers shoe (700 mm, 28")		●
Triple grousers shoe (800 mm, 32")		●
Double grousers shoe (700 mm, 28")		●
Track rail guard	●	
Full track rail guard		●

* Standard and optional equipment may vary. Contact your Hyundai dealer for more information.
 The machine may vary according to International standards.
 * The photos may include attachments and optional equipment that are not available in your area.
 * Materials and specifications are subject to change without advance notice.
 * All imperial measurements rounded off to the nearest pound or inch.

HX140 L

With Tier4 final / Stage IV Engine installed

* Photo may include optional equipment.



Head Office(Sales Office)
 14F, GLOBAL R&D CENTER, 477 BUNDANG SUSEO-RO, BUNDANG-GU, SEONGNAM-SI, GYEONGGI-DO, 13553, KOREA

2026. FEB

Gross Power
 SAE J1995 / 124Hp (92.6kW) at 1,950rpm

Net Power
 SAE J1349 / 116HP (87kW) at 1,950rpm

Travel Speed
 5.6km/hr (3.5mph) / 3.3km/hr (2.1mph)

Operating Weight
 14,200kg / 31,310lb

HYUNDAI



RULE THE GROUND

The HX Series excavators are products of HHI's spirit of initiative, creativity, and strong drive. HHI's engineers, who are the best in the industry, have worked tirelessly to offer a zero-defect product. The new HX Series reflects customers' needs in the field gleaned by thorough monitoring. They maximize fuel efficiency and performance proven by rigorous field tests and quality control.



*Photo may include optional equipment.

RULE THE GROUND

HX140

The HX series exceeds customer's expectation!
Become a true leader on the ground with HHI's HX series.



WORK MAX, WORTH MAX

- ECO Gauge
- IPC (Intelligent Power Control)
- New Variable Power Control
- Electronic Viscous Fan Clutch
- Attachment Flow Control **Option**
- New Cooling System with Increased Air Flow
- Enlarged Air Inlet with Grill Cover
- Cycle Time Improvement
- Boom Floating Control **Option**



MORE RELIABLE, MORE SUSTAINABLE

- Durable Cooling Module
- Reinforced Pin, Bush, and Polymer Shim
- Reinforced Durability of Upper and Lower Structure and Attachments
- Hi-grade (High-pressure) Hoses



INFOTAINMENT FRONTIER

- Intelligent and Wide Cluster
- Haptic Control
- Proportional Auxiliary Hydraulic System
- New Audio System
- New Air Conditioning System



MODERN COMFORT, SIMPLE AND SAFE SOLUTION

- AAVM (Advanced Around View Monitoring) Camera System **Option**
- Easy Access to DEF/AdBlue® Supply System
- Hi MATE (Remote Management System) **Option**
- Swing Lock System **Option**
- Fine Swing Control **Option**



*Photo may include optional equipment.

WORK MAX, WORTH MAX

Fuel Efficient System, Allows Great Performance

The HX Series has an eco-friendly, high-performance engine which ensures both excellent fuel efficiency and high power. With outstanding operating performance proven by rigorous tests at various work sites, it will satisfy any customer's needs.

90%
Reduction in PM & NOx
(Compared to 9 Series)



ECO Gauge

Eco Gauge enable economic operation of machines. The gauge level and color displays engine torque and fuel efficiency level. On top of that, the status of fuel consumption such as average rate and the total amount of fuel consumed are displayed. Hourly and daily based fuel consumption can be checked in the detailed menu as well.

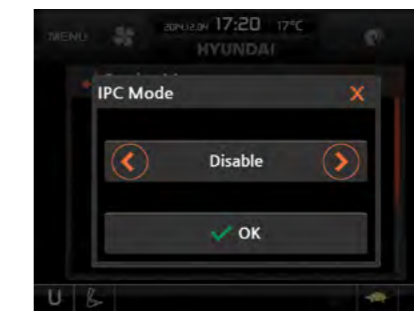

IPC (Intelligent Power Control)

The IPC controls Power depending on work environments. Its mode can be selected and released on the monitor. On the excavation mode, pump flow can be easily controlled by a lever, reducing fuel consumption.

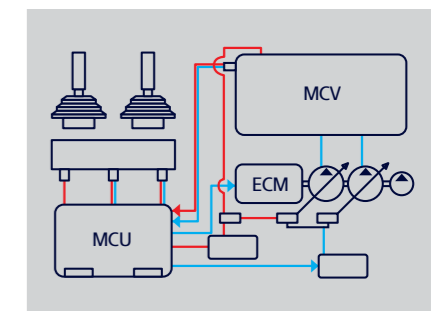

New Variable Power Control

The HX Series minimizes equipment input and output control signals to improve fuel efficiency. Its three-stage Power mode ensures the highest performance in any operating environment.

- * P(power) mode: Maximizes speed and power of the equipment for heavy load work.
- * S(standard) mode: Optimizes performance and fuel efficiency of the equipment for general load work.
- * E(economy) mode: Improves the control system for light load work.



*Photo may include optional equipment.

Cycle Time Improvement

The HX Series provides higher productivity on the site by faster operation: it loads trucks up to 5% faster and levels up to 2~5% faster than the 9 Series.

Boom Floating Control **Option**

In order to achieve efficient leveling work by arm-in and arm-out operation with the boom fixed, the HX Series applies boom floating control, allowing stable operation even in high-load work.



Attachment Flow Control

Option

The HX Series improves pump flow rate by independent control of two pumps. It optimizes attachments for effective flow rate setting depending on attachments (ten breaker types and ten crusher types), enabling various operations matching the site environments.



New Cooling System with Increased Air Flow

With the three-floor stacked cooling module improving air inflow, the HX Series provides excellent cooling performance by increasing heat dissipation and can be easily cleaned.

Electronic Viscous Fan Clutch

The electronic fan clutch reduces noise during operation by precisely controlling RPM depending on the hydraulic oil and coolant temperature of the working vehicle, and minimizes fuel consumption. It is also possible to shorten the warm up time of hydraulic oil.

Enlarged Air Inlet with Grill Cover

Enlarged vent hole of the air inlet side cover and fine net grill to prevent penetration of foreign materials further improve durability.

MORE RELIABLE, MORE SUSTAINABLE

New Exterior Design for Robustness and Safety

The true value of the HX Series lies in its durability. The robust upper and lower frame structure that can endure external shock and high-load work and the attachments whose performance was proven by rigorous tests further show the real value of the HX Series in tough working environments and promise higher productivity.

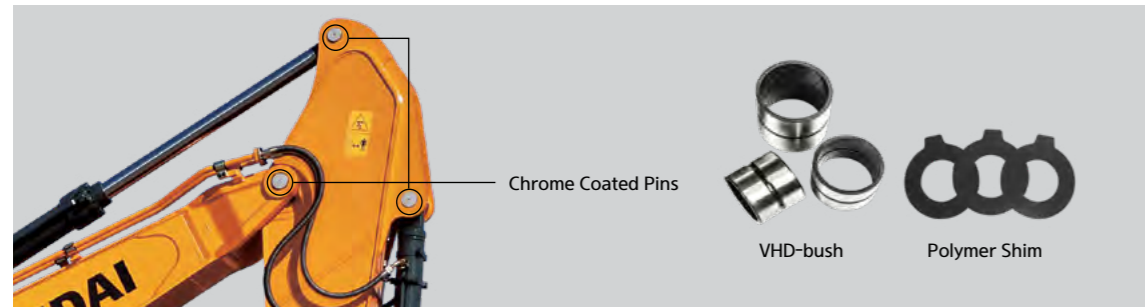

Reinforced Pin, Bush, and Polymer Shim

The HX series improves lubricity of connecting parts between the equipment and attachments. Gaps with attachments are minimized by wear-resistant long-life pins, bushes, and polymer shims, supporting the highest performance with invariable durability.



Durable Cooling Module

The HX Series has a durable cooling module that passed stringent tests, demonstrating the highest productivity in tough working environments.



Reinforced Durability of Upper and Lower Structure and Attachments

The upper and lower structure and attachments of the HX Series have higher durability than demanded on the site, as proven through numerous tests including road tests and virtual simulation. The wear resistance of the bucket has been improved by use of new material.



Hi-grade (High-pressure) Hoses

The HX Series uses high-pressure hoses with improved heat and pressure resistance, greatly increasing the durability of the equipment.



INFOTAINMENT FRONTIER

Enhanced Instrument Panel for Easier Monitoring

Many electronic functions are concentrated on the most convenient spot for operators to ensure work efficiency. The highly-advanced infotainment system, a product of HHI's intensive information technology, enables both productivity and pleasant work at the same time! The HX Series of HHI provides higher value and pleasure to customers.



Intelligent and Wide Cluster

The 8-inch capacitive-type display (like smartphone display) of the HX Series is 15% larger than the previous model, delivering excellent legibility. The centralized switches on the display allow convenience of checking the urea level and temperature outside the cabin. The audio AUX, air conditioner, heater interoperation, wiper, lamp, overload warning, travel, alarm and inclination sensor also maximize operator's convenience.

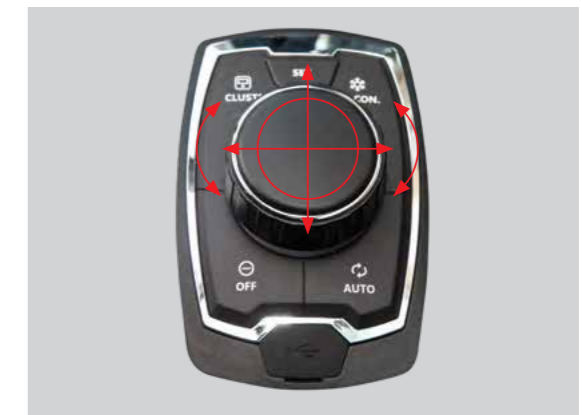

Haptic Control

The integrated jog shuttle-type haptic controller applies to the accelerator, remote air conditioner controller, and operate cluster, allowing convenient operation. In the event of failure of the haptic switch, the emergency mode is activated on the cluster to ensure fail-safe function.



New Audio System

Radio player, USB-based MP3 player, integrated Bluetooth hands-free feature, and built-in microphone allow convenient phone calls while in work and in transit. The radio player was moved to the right side from the rear, allowing easier access.

Proportional Auxiliary Hydraulic System

- Opt: Proportional control switch for better speed control
- Enlarge the operation convenience



New Air Conditioning System

With further improved air conditioning and heating, the HX Series increases the APTC capacity by 15% to provide a pleasant environment for operators all the time. The ventilation was designed such that warm and cool air even reach operators' faces (increasing their work satisfaction) or allowing pleasant working environment.

MODERN COMFORT, SIMPLE AND SAFE SOLUTION

New Cabin for More Comfort

Low noise, low vibration, and ergonomic design make the cabin space more comfortable and pleasant! With focus on safety and convenience of operators, the HX Series allows rapid and safe equipment inspection anytime and anywhere, providing an optimal environment for operators to work.



AAVM (Advanced Around View Monitoring) Camera System **Option**

The HX Series has a state-of-the-art AAVM video camera system to secure field of vision for operators in all directions, thereby preventing accidents. Operators can easily check the workplace in the front and rear and to the right and left.



*AVM (Around View Monitoring): Secure field of vision in all directions by nine views including 3D bird's eye view and 2D/4CH view.

*IMOD (Intelligent Moving Object Detection): Inform when people or dangerous objects are detected within the range of operation (recognition distance: 5 m).



Easy Access to DEF/AdBlue® Supply System

The DEF/AdBlue® tank is installed inside the tool box and its inlet is remotely located for easy access and convenient supply. Warning of overfill is given by a red lamp signal. The DEF/AdBlue® supply module is attached on the side of the fuel tank for easy maintenance and filter replacement.



Hi MATE (Remote Management System) **Option**

Hi MATE, Hyundai's proprietary remote management system, provides operators and dealer service personnel access to vital service and diagnostic information on the machine from any computer with internet access. Users can pinpoint machine location using digital mapping and set machine work boundaries, reducing the need for multiple service calls. Hi MATE saves time and money for the owner and dealer by promoting preventative maintenance and reducing machine downtime.

* Operation of the system may be affected by the condition of telecommunication signal



*Photo may include optional equipment.

Swing Lock System **Option**

Swing Lock System is provided to maintain stability when swing movement needs to be limited, improving operating speed and productivity.

Fine Swing Control **Option**

Fine swing control is available for customer's convenience when users want to control fine swing.

SPECIFICATIONS

ENGINE		
Maker / Model	PERKINS / 1204F-E44TAN	
Type	4-cycle turbocharged, charger air cooled diesel engine	
Rated flywheel horse power	SAE J1995 (gross)	124 Hp (92.6 kW) at 1,950 rpm
	J1349 (net)	116 HP (87 kW) at 1,950 rpm
DIN	6271/1 (gross)	126 PS (92.6 kW) at 1,950 rpm
	6271/1 (net)	118 PS (87 kW) at 1,950 rpm
Max. torque	54 kgf · m (391 lbf · ft) / 1,400 rpm	
Bore × stroke	105 × 127 mm (4.13" × 5")	
Piston displacement	4,400 cc (269 cu in)	
Batteries	2 × 12 V × 80 Ah	
Starting motor	24V, 4.5 kW	
Alternator	24V, 100 Amp	

HYDRAULIC SYSTEM	
MAIN PUMP	
Type	Variable displacement tandem axis piston pumps
Max. flow	2 × 126.8 l/min
Sub-pump for pilot circuit	Gear pump

Cross-sensing and fuel saving pump system

HYDRAULIC MOTORS	
Travel	Two speed axial pistons motor with brake valve and parking brake
Swing	Axial piston motor with automatic brake

RELIEF VALVE SETTING	
Implement circuits	350 kgf/cm ² (4980psi)
Travel	350 kgf/cm ² (4980psi)
Power boost (boom, arm, bucket)	380 kgf/cm ² (5400psi)
Swing circuit	285 kgf/cm ² (4054psi)
Pilot circuit	40 kgf/cm ² (570psi)
Service valve	Installed

HYDRAULIC CYLINDERS	
No. of cylinder bore X stroke	Boom: Ø120 × 1,290 mm
	Arm: Ø140 × 1,510 mm
	Bucket: Ø120 × 1,055 mm

DRIVES & BRAKES	
Drive method	Fully hydrostatic type
Drive motor	Axial piston motor, in-shoe design
Reduction system	Planetary reduction gear
Max. drawbar pull	12,000 kgf (26,455 lbf)
Max. travel speed (high / low)	5.6 km/hr (3.5 mph) / 3.3 km/hr (2.1 mph)
Gradeability	35° (70%)
Parking brake	Multi wet disc

CONTROL	
Pilot pressure operated joysticks and pedals with detachable lever provide almost effortless and fatigueless operation.	
Pilot control	Two joysticks with one safety lever (LH): Swing and arm(RH)Boom and bucket
Traveling and steering	Two levers with pedals
Engine throttle	Electric, Dial type

SWING SYSTEM	
Swing motor	Fixed displacement axial piston motor
Swing reduction	Planetary gear reduction
Swing bearing lubrication	Grease-bathed
Swing brake	Multi wet disc
Swing speed	11.6 rpm

SERVICE REFILL CAPACITIES			
Re-filling	liter	US gal	UK gal
Fuel tank	270.0	71.3	59.4
Engine coolant	15.5	4.1	3.4
Engine oil	10.5	2.8	2.3
Swing device	2.5	0.66	0.55
Final drive (each)	2.2	0.60	0.50
Hydraulic system (including tank)	210.0	55.5	46.2
Hydraulic tank	124.0	32.8	27.3
DEF/AdBlue®	19	5	4.2

UNDERCARRIAGE	
The X-leg type center frame is integrally welded with reinforced box-section track frames. The undercarriage includes lubricated rollers, idlers, track adjusters with shock absorbing springs and sprockets, and a track chain with double or triple grouser shoes.	
Center frame	X - leg type
Track frame	Pentagonal box type
No. of shoes on each side	46 EA
No. of carrier roller on each side	1 EA
No. of track roller on each side	7 EA
No. of rail guard on each side	1 EA

OPERATING WEIGHT (APPROXIMATE)	
Operating weight, including 4,600mm (15' 1") boom, 2,500mm (8' 2") arm, SAE heaped 0.58m ³ (0.76 yd ³) bucket, lubricant, coolant, full fuel tank, full hydraulic tank, and all standard equipments.	

OPERATING WEIGHT			
Shoes	Operating weight		Ground pressure
Type	Width mm (in)	kg (lb)	kgf/cm ² (psi)
500 (20")	HX140 L	13,990 (30,840)	0.43 (6.11)
	HX140 LD	14,810 (32,650)	0.46 (6.54)
Triple grouser 600 (24")	HX140 L	14,200 (31,310)	0.37 (5.26)
	HX140 LD	15,020 (33,110)	0.39 (5.55)
	HX140 L	14,410 (31,770)	0.32 (4.55)
800 (32")	HX140 L	14,410 (31,770)	0.32 (4.55)
	HX140 HW	17,100 (37,700)	0.33 (4.69)
Double grouser 710 (28")	HX140 HW	16,865 (37,180)	0.37 (5.26)

AIR CONDITIONING SYSTEM	
The air condition system for the machine contains the fluorinated greenhouse gas with global warming potential of R134a. (Global Warming Potential : 1430)	
The system hold 0.65kg refrigerant consisting of a CO ₂ equivalent 0.93kg metric tonne. For more information, Please refer to the manual.	

BUCKET SELECTION GUIDE & DIGGING FORCE

BUCKETS

SAE heaped m ³ (yd ³)	0.23 (0.30)	0.40 (0.52)	0.52 (0.68)	0.65 (0.85)	◆ 0.45 (0.59)	◆ 0.55 (0.72)
		0.46 (0.60)	0.58 (0.76)	0.71 (0.93)		

Capacity m ³ (yd ³)	Width mm (in)	Weight kg (lb)	Recommendation mm (ft.in)					
			4,600 (15' 1") Boom				4,100 (13' 5") Boom	
			1,900 (6' 3") Arm	2,100 (6' 11") Arm	2,500 (8' 2") Arm	3,000 (9' 10") Arm	1,900 (6' 3") Arm	2,100 (6' 11") Arm
0.23 (0.30)	220(20.5)	335(740)	●	●	●	■	●	●
0.40 (0.52)	250(29.5)	410(900)	●	●	●	■	●	●
0.46 (0.60)	280(33.1)	435(960)	●	●	●	▲	●	●
0.52 (0.68)	310(36.0)	460(1,010)	●	●	●	-	●	●
0.58 (0.76)	340(39.4)	480(1,060)	●	●	■	-	●	●
0.65 (0.85)	370(43.5)	500(1,100)	■	■	▲	-	●	■
0.71 (0.93)	400(46.9)	540(1,190)	▲	▲	-	-	■	▲
◆ 0.45 (0.59)	350(59.8)	410(900)	●	●	■	-	●	●
◆ 0.55 (0.72)	300(70.9)	585(1,290)	■	■	▲	-	●	●

◆ Ditching bucket

◆ Slope finishing bucket

● : Applicable for materials with density of 2,000 kgf/m³ (3,370 lbf/yd³) or less

■ : Applicable for materials with density of 1,600 kgf/m³ (2,700 lbf/yd³) or less

▲ : Applicable for materials with density of 1,100 kgf/m³ (1,850 lbf/yd³) or less

ATTACHMENT

Booms and arms are welded, a low-stress, full-box section design.

4.1 m (13' 5"), 4.6 (15' 1") mono booms & 4.9 m (16' 9") hydraulic adjustable boom and 1.9 m (6' 3"): 2.1 m (6' 11"): 2.5 m (8' 2") & 3.0 m (9' 1") arms are available.

DIGGING FORCE							
Arm	Length	mm (ft.in)	1,900 (6' 3")	2,100 (6' 11")	2,500 (8' 2")	3,000 (9' 10")	Remark
	Weight	kg (lb)	560 (1,230)	580 (1,280)	610 (1,340)	670 (1,480)	
Bucket digging force	SAE	kN	87.3[94.8]	87.3[94.8]	87.3[94.8]	87.3[94.8]	[] : Power Boost
		kgf	8,900[9,660]	8,900[9,660]	8,900[9,660]	8,900[9,660]	
		lbf	19,620[21,300]	19,620[21,300]	19,620[21,300]	19,620[21,300]	
	ISO	kN	102[110.8]	102[110.8]	102[110.8]	102[110.8]	
		kgf	10,400[11,290]	10,400[11,290]	10,400[11,290]	10,400[11,290]	
		lbf	22,930[24,890]	22,930[24,890]	22,930[24,890]	22,930[24,890]	
Arm crowd force	SAE	kN	76.5[83.1]	73.6[79.9]	62.8[68.2]	55.9[60.7]	
		kgf	7,800[8,470]	7,500[8,140]	6,400[6,950]	5,700[6,190]	
		lbf	17,200[18,670]	16,530[17,950]	14,110[15,320]	12,570[13,640]	
	ISO	kN	80.4[87.3]	77.5[84.1]	65.7[71.4]	57.9[62.8]	
		kgf	8,200[8,900]	7,900[8,580]	6,700[7,270]	5,900[6,410]	
		lbf	18,080[19,630]	17,420[18,910]	14,770[16,040]	13,010[14,120]	

Note : Arm weight includes bucket cylinder, linkage, and pin

DIMENSIONS & WORKING RANGE

HX140 L DIMENSIONS

4.6 m (15' 1"), 4.1 m (13' 5") BOOM and 1.9 m (6' 3"), 2.1 m (6' 11"), 2.5 m (8' 2"), 3.0 m (9' 10") ARM

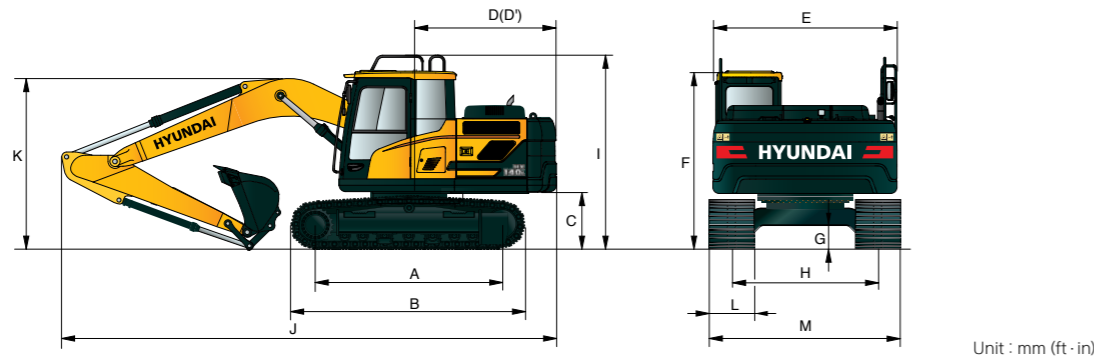

A	Tumbler distance	3,000 (9' 10")
B	Overall length of crawler	3,708 (12' 2")
C	Ground clearance of counterweight	940 (3' 1")
D	Tail swing radius	2,330 (7' 7")
D'	Rear-end length	2,330 (7' 7")
E	Overall width of upperstructure	2,475 (8' 1")
F	Overall height of cab	2,860 (9' 5")
G	Min. ground clearance	440 (1' 5")
H	Track gauge	2,000 (6' 7")
I	Overall height of guardrail	3,100 (10' 2")

Boom length	4,600 (15' 1")				4,100 (13' 5")	
Arm length	1,900 (6' 3")	2,100 (6' 11")	2,500 (8' 2")	3,000 (9' 10")	1,900 (6' 3")	2,100 (6' 11")
J Overall length	7,820 (25' 7")	7,850 (25' 8")	7,820 (25' 7")	7,790 (25' 6")	7,320 (24' 0")	7,350 (24' 1")
K Overall height of boom	2,650 (8' 7")	2,760 (9' 0")	2,780 (9' 1")	3,110 (10' 2")	2,600 (8' 5")	2,790 (9' 2")
L Track shoe width	500 (20")		600 (24")		700 (28")	
M Overall width	2,500 (8' 2")		2,600 (8' 6")		2,700 (8' 10")	

HX140 L WORKING RANGE

Unit : mm (ft · in)

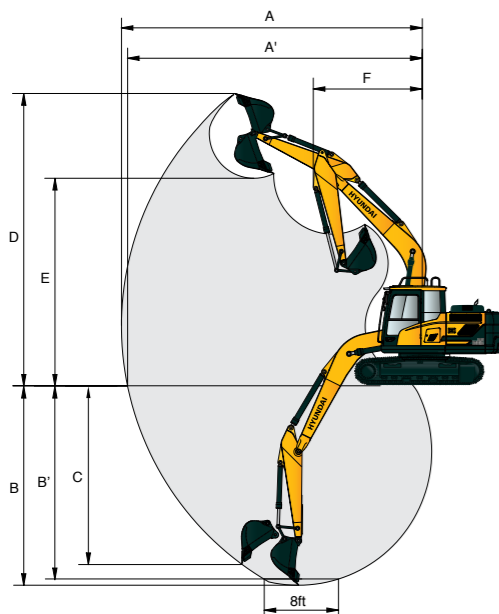

Boom length	4,600 (15' 1")				4,100 (13' 5")	
Arm length	1,900 (6' 3")	2,100 (6' 11")	2,500 (8' 2")	3,000 (9' 10")	1,900 (6' 3")	2,100 (6' 11")
A Max. digging reach	7,750 (25' 5")	7,920 (25' 11")	8,330 (27' 4")	8,790 (28' 10")	7,260 (23' 10")	7,420 (24' 4")
A' Max. digging reach on ground	7,600 (24' 11")	7,770 (25' 6")	8,180 (26' 10")	8,650 (28' 4")	7,090 (23' 3")	7,260 (23' 10")
B Max. digging depth	4,950 (16' 2")	5,150 (16' 10")	5,550 (18' 3")	6,050 (19' 10")	4,540 (14' 11")	4,740 (15' 7")
B' Max. digging depth (8' level)	4,680 (15' 4")	4,900 (16' 1")	5,340 (17' 6")	5,870 (19' 3")	4,280 (14' 1")	4,490 (14' 9")
C Max. vertical wall digging depth	4,650 (15' 3")	4,900 (16' 1")	5,330 (17' 6")	5,850 (19' 2")	4,240 (13' 11")	4,350 (14' 3")
D Max. digging height	8,100 (26' 7")	8,180 (26' 10")	8,500 (27' 11")	8,780 (28' 10")	7,700 (25' 3")	7,770 (25' 6")
E Max. dumping height	5,670 (18' 7")	5,750 (18' 10")	6,060 (19' 11")	6,330 (20' 9")	5,260 (17' 3")	5,340 (17' 6")
F Min. swing radius	2,630 (8' 8")	2,670 (8' 9")	2,650 (8' 8")	2,680 (8' 10")	2,350 (7' 9")	2,460 (8' 1")

HX140 LD DIMENSIONS

4.6 m (15' 1"), 4.1 m (13' 5") BOOM and 1.9 m (6' 3"), 2.1 m (6' 11"), 2.5 m (8' 2"), 3.0 m (9' 10") ARM

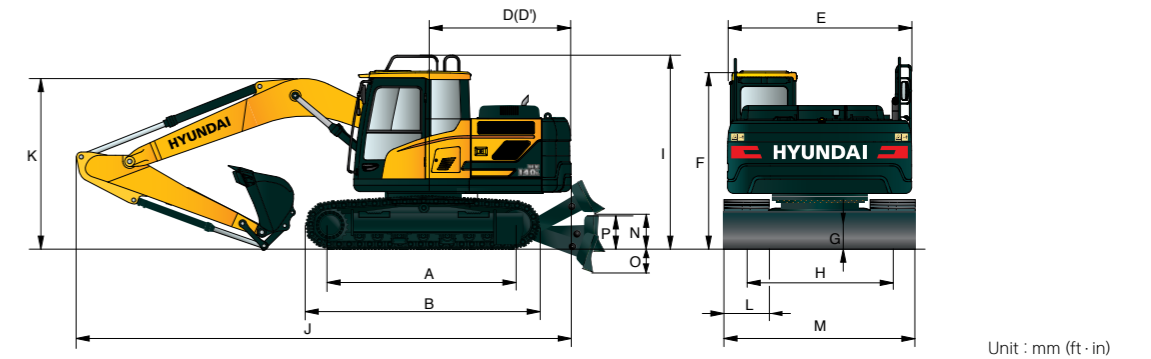

A	Tumbler distance	3,000 (9' 10")
B	Overall length of crawler	3,708 (12' 2")
C	Ground clearance of counterweight	940 (3' 1")
D	Tail swing radius	2,330 (7' 7")
D'	Rear-end length	2,330 (7' 7")
E	Overall width of upperstructure	2,475 (8' 1")
F	Overall height of cab	2,960 (9' 9")
G	Min. ground clearance	440 (1' 5")
H	Track gauge	2,000 (6' 7")
I	Overall height of guardrail	3,180 (10' 5")
N	Ground clearance of blade up	560 (1' 10")
O	Depth of dozer blade	500 (1' 8")
P	Height of blade	575 (1' 11")

Boom length	4,600 (15' 1")				4,100 (13' 5")	
Arm length	1,900 (6' 3")	2,100 (6' 11")	2,500 (8' 2")	3,000 (9' 10")	1,900 (6' 3")	2,100 (6' 11")
J Overall length	8,130 (26' 7")	8,160 (26' 7")	8,130 (26' 7")	8,100 (26' 6")	7,630 (25' 0")	7,660 (25' 1")
K Overall height of boom	2,650 (8' 7")	2,760 (9' 0")	2,780 (9' 1")	3,110 (10' 2")	2,600 (8' 5")	2,790 (9' 2")
L Track shoe width	500 (20")		600 (24")		700 (28")	
M Overall width	2,500 (8' 2")		2,600 (8' 6")		2,700 (8' 10")	

HX140 LD WORKING RANGE

Unit : mm (ft · in)

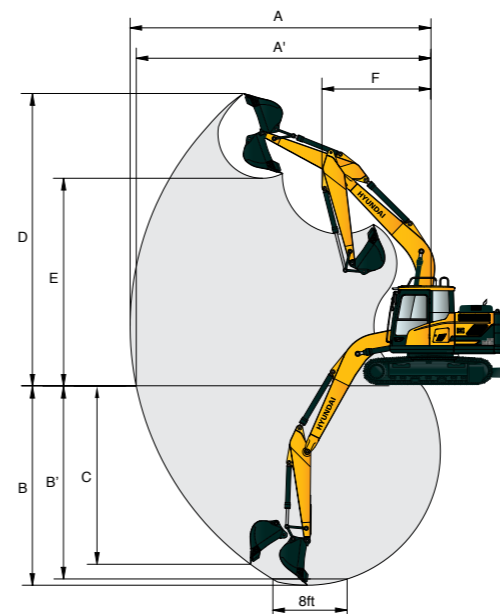

Boom length	4,600 (15' 1")				4,100 (13' 5")	
Arm length	1,900 (6' 3")	2,100 (6' 11")	2,500 (8' 2")	3,000 (9' 10")	1,900 (6' 3")	2,100 (6' 11")
A Max. digging reach	7,750 (25' 5")	7,920 (25' 11")	8,330 (27' 4")	8,790 (28' 10")	7,260 (23' 10")	7,420 (24' 4")
A' Max. digging reach on ground	7,600 (24' 11")	7,770 (25' 6")	8,180 (26' 10")	8,650 (28' 4")	7,090 (23' 3")	7,260 (23' 10")
B Max. digging depth	4,950 (16' 2")	5,150 (16' 10")	5,550 (18' 3")	6,050 (19' 10")	4,540 (14' 11")	4,740 (15' 7")
B' Max. digging depth (8' level)	4,680 (15' 4")	4,900 (16' 1")	5,340 (17' 6")	5,870 (19' 3")	4,280 (14' 1")	4,490 (14' 9")
C Max. vertical wall digging depth	4,650 (15' 3")	4,900 (16' 1")	5,330 (17' 6")	5,850 (19' 2")	4,240 (13' 11")	4,350 (14' 3")
D Max. digging height	8,100 (26' 7")	8,180 (26' 10")	8,500 (27' 11")	8,780 (28' 10")	7,700 (25' 3")	7,770 (25' 6")
E Max. dumping height	5,670 (18' 7")	5,750 (18' 10")	6,060 (19' 11")	6,330 (20' 9")	5,260 (17' 3")	5,340 (17' 6")
F Min. swing radius	2,630 (8' 8")	2,670 (8' 9")	2,650 (8' 8")	2,680 (8' 10")	2,350 (7' 9")	2,460 (8' 1")

DIMENSIONS & WORKING RANGE

HX140 HW DIMENSIONS

4.6 m (15' 1"), 4.1 m (13' 5") BOOM and 1.9 m (6' 3"), 2.1 m (6' 11"), 2.5 m (8' 2"), 3.0 m (9' 10") ARM

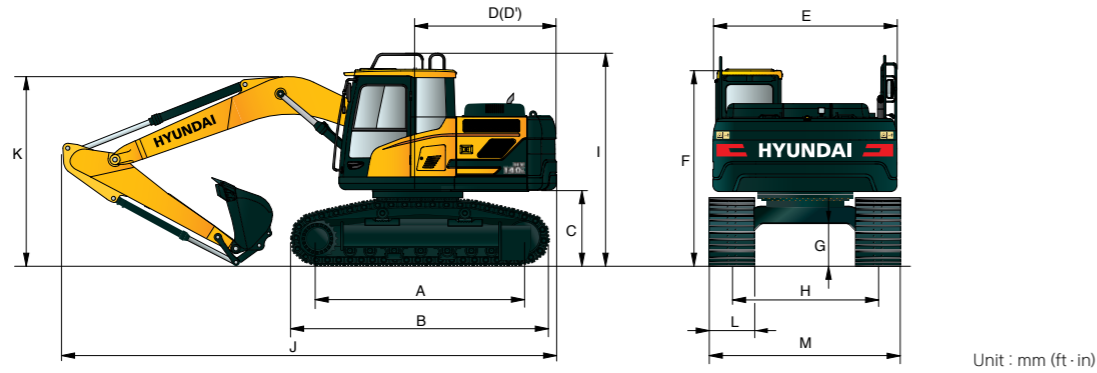

A	Tumbler distance	3,030 (9' 11")
B	Overall length of crawler	3,740 (12' 3")
C	Ground clearance of counterweight	1,200 (3' 11")
D	Tail swing radius	2,330 (7' 7")
D'	Rear-end length	2,330 (7' 7")
E	Overall width of upperstructure	2,475 (8' 1")
F	Overall height of cab	3,220 (10' 7")
G	Min. ground clearance	600 (1' 12")
H	Track gauge	2,040 (6' 8")
I	Overall height of guardrail	3,440 (11' 3")

Boom length	4,600 (15' 1")				4,100 (13' 5")		
Arm length	1,900 (6' 3")	2,100 (6' 11")	2,500 (8' 2")	3,000 (9' 10")	1,900 (6' 3")	2,100 (6' 11")	
J	Overall length	7,770 (25' 5")	7,830 (25' 7")	7,790 (25' 6")	7,860 (25' 8")	7,220 (23' 8")	7,290 (23' 11")
K	Overall height of boom	2,750 (9' 0")	2,860 (9' 4")	2,830 (9' 3")	3,120 (10' 2")	2,650 (8' 1")	2,850 (9' 4")
L	Track shoe width	700 (28")				800 (32")	
M	Overall width	2,740 (8' 12")		2,840 (9' 4")			

HX140 HW WORKING RANGE

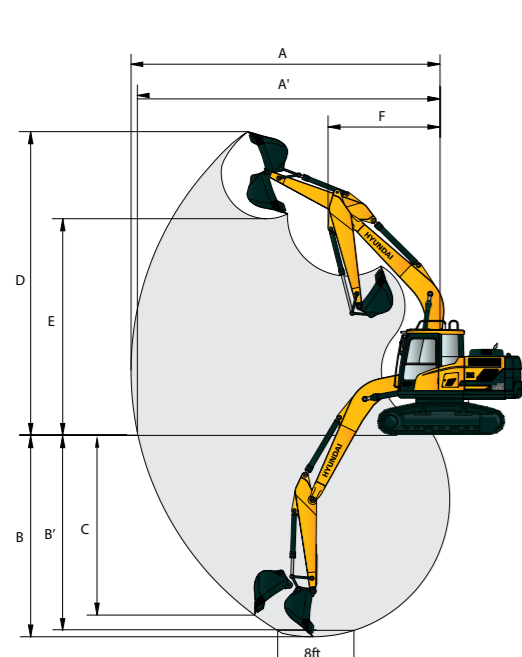

Boom length	4,600 (15' 1")				4,100 (13' 5")		
Arm length	1,900 (6' 3")	2,100 (6' 11")	2,500 (8' 2")	3,000 (9' 10")	1,900 (6' 3")	2,100 (6' 11")	
A	Max. digging reach	7,750 (25' 5")	7,920 (25' 11")	8,330 (27' 4")	8,790 (28' 10")	7,260 (23' 10")	7,420 (24' 4")
A'	Max. digging reach on ground	7,540 (24' 9")	7,710 (25' 4")	8,110 (26' 7")	8,580 (28' 2")	7,020 (23' 10")	7,200 (23' 7")
B	Max. digging depth	4,690 (15' 5")	4,890 (16' 1")	5,290 (17' 4")	5,790 (19' 0")	4,280 (14' 1")	4,480 (14' 8")
B'	Max. digging depth (8' level)	4,420 (14' 6")	4,640 (15' 3")	5,080 (16' 8")	5,610 (18' 5")	4,020 (13' 2")	4,230 (13' 11")
C	Max. vertical wall digging depth	4,390 (14' 5")	4,640 (15' 3")	5,070 (16' 8")	5,590 (18' 4")	3,980 (13' 1")	4,090 (13' 5")
D	Max. digging height	8,360 (27' 5")	8,440 (27' 8")	8,760 (28' 9")	9,040 (29' 7")	7,960 (26' 1")	8,030 (26' 4")
E	Max. dumping height	5,930 (19' 5")	6,010 (19' 8")	6,320 (20' 9")	6,590 (21' 7")	5,520 (18' 1")	5,600 (18' 4")
F	Min. swing radius	2,630 (8' 8")	2,670 (8' 9")	2,650 (8' 8")	2,680 (8' 10")	2,350 (7' 9")	2,460 (8' 1")

HX140 L 2-PIECE BOOM DIMENSIONS

4.9 m (16' 1") 2-PIECE BOOM and 1.9 m (6' 3"), 2.1 m (6' 11"), 2.5 m (8' 2"), 3.0 m (9' 10") ARM

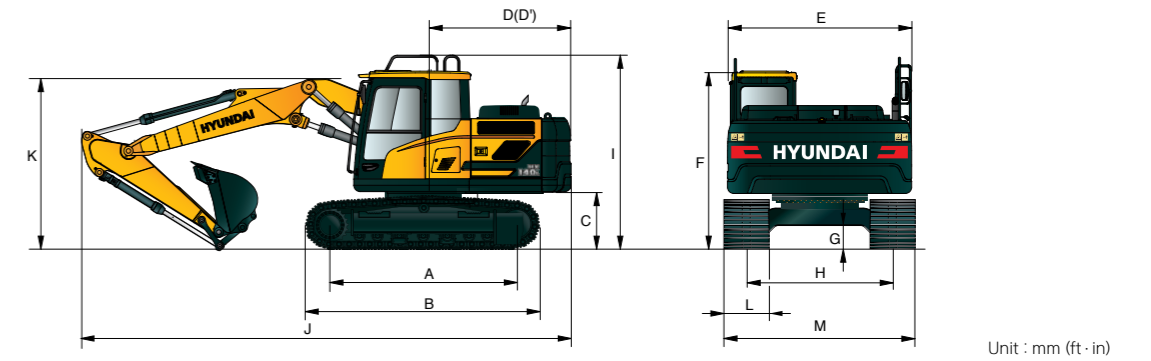

A	Tumbler distance	3,000 (9' 10")
B	Overall length of crawler	3,750 (12' 4")
C	Ground clearance of counterweight	940 (3' 1")
D	Tail swing radius	2,330 (7' 7")
D'	Rear-end length	2,330 (7' 7")
E	Overall width of upperstructure	2,500 (8' 2")
F	Overall height of cab	2,870 (9' 4")
G	Min. ground clearance	440 (1' 5")
H	Track gauge	2,000 (6' 7")
I	Overall height of guardrail	3,100 (10' 2")

Boom length	4,900 (16' 1") 2-Piece boom			
Arm length	1,900 (6' 3")	2,100 (6' 11")	2,500 (8' 2")	
J	Overall length	8,160 (26' 8")	8,170 (26' 8")	8,150 (26' 8")
K	Overall height of boom	2,830 (9' 3")	2,940 (9' 6")	2,960 (9' 7")
L	Track shoe width	500 (20")	600 (24")	700 (28")
M	Overall width	2,500 (8' 2")	2,600 (8' 6")	2,700 (8' 10")

HX140 L 2-PIECE BOOM WORKING RANGE

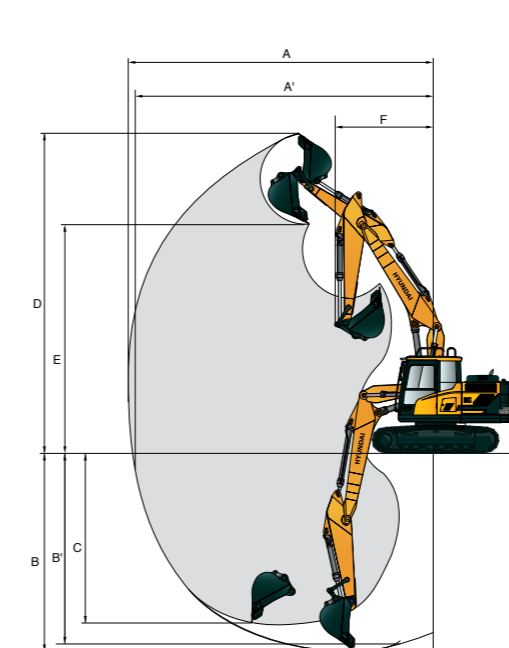

Boom length	4,900 (16' 1") 2-Piece boom			
Arm length	1,900 (6' 3")	2,100 (6' 11")	2,500 (8' 2")	
A	Max. digging reach	8,140 (26' 8")	8,320 (27' 4")	8,720 (28' 7")
A'	Max. digging reach on ground	8,000 (26' 3")	8,180 (26' 10")	8,590 (28' 2")
B	Max. digging depth	5,110 (16' 9")	5,310 (17' 5")	5,710 (18' 9")
B'	Max. digging depth (8' level)	5,000 (16' 5")	5,190 (17' 0")	5,610 (18' 5")
C	Max. vertical wall digging depth	4,490 (14' 9")	4,660 (15' 3")	5,120 (16' 10")
D	Max. digging height	8,810 (28' 11")	8,890 (29' 2")	9,270 (30' 5")
E	Max. dumping height	6,330 (20' 9")	6,410 (21' 0")	6,780 (22' 3")
F	Min. swing radius	2,670 (8' 9")	2,830 (9' 3")	2,690 (8' 10")

LIFTING CAPACITY

Rating over-front Rating over-side or 360 degree

HX140 L

Boom : 4.6 m (15' 1") / Arm : 1.9 m (6' 3") / Bucket : 0.58 m³ (0.76 yd³) SAE heaped / Shoe : 600 mm (24") triple grouser

Load point height m (ft)	Load radius								At max. reach		
	1.5 m (5 ft)		3.0 m (10 ft)		4.5 m (15 ft)		6.0 m (20 ft)		Capacity	Reach	
6.0 m (20 ft)	kg				*3,340	*3,340			*3,170	2,350	5.95
	lb				*7,360	*7,360			*6,990	5,180	(19.5)
4.5 m (15 ft)	kg				*3,550	*3,550			2,820	1,760	6.90
	lb				*7,830	*7,830			6,220	3,880	(22.6)
3.0 m (10 ft)	kg			*6,270	*6,270	*4,440	3,510	3,480	2,480	1,520	7.37
	lb			*13,820	*13,820	*9,790	7,740	7,670	5,470	3,350	(24.2)
1.5 m (5 ft)	kg			*8,490	6,040	5,400	3,270	3,380	2,390	1,450	7.45
	lb			*18,720	13,320	11,900	7,210	7,450	5,270	3,200	(24.4)
Ground Line	kg			*8,230	5,790	5,200	3,100	3,300	2,510	1,520	7.17
	lb			*18,140	12,760	11,460	6,830	7,280	5,530	3,350	(23.5)
-1.5 m (-5 ft)	kg	*6,670	*6,670	*9,690	5,800	5,140	3,050		2,960	1,810	6.48
	lb	*14,700	*14,700	*21,360	12,790	11,330	6,720		6,530	3,990	(21.3)
-3.0 m (-10 ft)	kg	*10,970	*10,970	*8,330	5,930	5,220	3,110		*3,690	2,670	5.15
	lb	*24,180	*24,180	*18,360	13,070	11,510	6,860		*8,140	5,890	(16.9)

Boom : 4.6 m (15' 1") / Arm : 2.5 m (8' 2") / Bucket : 0.58 m³ (0.76 yd³) SAE heaped / Shoe : 600 mm (24") triple grouser

Load point height m (ft)	Load radius								At max. reach			
	1.5 m (5 ft)		3.0 m (10 ft)		4.5 m (15 ft)		6.0 m (20 ft)		Capacity	Reach		
6.0 m (20 ft)	kg								*2,810	1,920	6.69	
	lb								*6,190	4,230	(21.9)	
4.5 m (15 ft)	kg							*2,770	2,270	2,440	1,500	7.53
	lb							*6,110	5,000	5,380	3,310	(24.7)
3.0 m (10 ft)	kg			*4,930	*4,930	*3,830	3,570	*3,380	2,190	2,170	1,310	7.95
	lb			*10,870	*10,870	*8,440	7,870	*7,450	4,830	4,780	2,890	(26.1)
1.5 m (5 ft)	kg			*8,030	6,240	*5,010	3,300	3,380	2,070	2,100	1,250	8.03
	lb			*17,700	13,760	*11,050	7,280	7,450	4,560	4,630	2,760	(26.3)
Ground Line	kg			*8,780	5,800	5,200	3,090	3,270	1,970	2,180	1,300	7.77
	lb			*19,360	12,790	11,460	6,810	7,210	4,340	4,810	2,870	(25.5)
-1.5 m (-5 ft)	kg	*5,740	*5,740	*9,910	5,700	5,080	2,990	3,220	1,920	2,500	1,500	7.15
	lb	*12,650	*12,650	*21,850	12,570	11,200	6,590	7,100	4,230	5,510	3,310	(23.5)
-3.0 m (-10 ft)	kg	*8,760	*8,760	*9,040	5,770	5,100	3,000		3,340	2,030	6.01	
	lb	*19,310	*19,310	*19,930	12,720	11,240	6,610		7,360	4,480	(19.7)	
-4.5 m (-15 ft)	kg			*6,590	6,030							
	lb			*14,530	13,290							

Boom : 4.6 m (15' 1") / Arm : 3.0 m (9' 10") / Bucket : 0.58 m³ (0.76 yd³) SAE heaped / Shoe : 600 mm (24") triple grouser

Load point height m (ft)	Load radius										At max. reach			
	1.5 m (5 ft)		3.0 m (10 ft)		4.5 m (15 ft)		6.0 m (20 ft)		7.5 m (25 ft)		Capacity	Reach		
6.0 m (20 ft)	kg										*2,540	1,650	7.25	
	lb										*5,600	3,640	(23.8)	
4.5 m (15 ft)	kg										2,180	1,320	8.02	
	lb										4,810	2,910	(26.3)	
3.0 m (10 ft)	kg					*3,280	*3,280	*3,020	2,210	*1,660	1,430	1,960	1,160	8.41
	lb					*7,230	*7,230	*6,660	4,870	*3,660	3,150	4,320	2,560	(27.6)
1.5 m (5 ft)	kg			*6,980	6,440	*4,540	3,350	3,400	2,080	*2,190	1,380	1,890	1,100	8.49
	lb			*15,390	14,200	*10,010	7,390	7,500	4,590	*4,830	3,040	4,170	2,430	(27.9)
Ground Line	kg			*9,240	5,850	5,210	3,100	3,260	1,960	*2,120	1,330	1,960	1,140	8.25
	lb			*20,370	12,900	11,490	6,830	7,190	4,320	*4,670	2,930	4,320	2,510	(27.1)
-1.5 m (-5 ft)	kg	*5,290	*5,290	*9,910	5,650	5,060	2,960	3,180	1,890		2,200	1,290	7.67	
	lb	*11,660	*11,660	*21,850	12,460	11,160	6,530	7,010	4,170		4,850	2,840	(25.2)	
-3.0 m (-10 ft)	kg	*7,720	*7,720	*9,440	5,670	5,030	2,940	3,180	1,880		2,800	1,680	6.64	
	lb	*17,020	*17,020	*20,810	12,500	11,090	6,480	7,010	4,140		6,170	3,700	(21.8)	
-4.5 m (-15 ft)	kg	*11,300	*11,300	*7,670	5,850	*4,890	3,050							
	lb	*24,910	*24,910	*16,910	12,900	*10,780	6,720							

- Lifting capacity are based on ISO 10567.
- Lifting capacity of the ROBEX series does not exceed 75% of tipping load with the machine on firm, level ground or 87% of full hydraulic capacity.
- The load point is a hook located on the back of the bucket.
- (*) indicates load limited by hydraulic capacity.

Rating over-front Rating over-side or 360 degree

HX140 LD

Boom : 4.6 m (15' 1") / Arm : 1.9 m (6' 3") / Bucket : 0.58 m³ (0.76 yd³) SAE heaped / Shoe : 600 mm (24") triple grouser

Load point height m (ft)	Load radius								At max. reach				
	1.5 m (5 ft)		3.0 m (10 ft)		4.5 m (15 ft)		6.0 m (20 ft)		Capacity	Reach			
6.0 m (20 ft)	kg								*3,340	*3,340	5.95		
	lb								*7,360	*7,360	(19.5)		
4.5 m (15 ft)	kg								*3,550	*3,550	6.90		
	lb								*7,830	*7,830	(22.6)		
3.0 m (10 ft)	kg			*6,270	*6,270	*4,440	3,700	3,780	2,300	3,700	2,710	1,620	7.37
	lb			*13,820	*13,820	*9,790	8,160	8,330	5,070	8,330	5,970	3,570	(24.2)
1.5 m (5 ft)	kg			*8,490	6,380	*5,520	3,460	3,680	2,210	3,680	2,610	1,550	7.45
	lb			*18,720	14,070	*12,170	7,630	8,110	4,870	8,110	5,750	3,420	(24.4)
Ground Line	kg			*8,230	6,130	5,650	3,290	3,590	2,130	3,590	2,750	1,630	7.17
	lb			*18,140	13,510	12,460	7,250	7,910	4,700	7,910	6,060	3,590	(23.5)
-1.5 m (-5 ft)	kg	*6,670	*6,670	*9,690	6,140	5,590	3,240				3,230	1,930	6.48
	lb	*14,700	*14,700	*21,360	13,540	12,320	7,140				7,120	4,250	(21.3)
-3.0 m (-10 ft)	kg	*10,970	*10,970	*8,330	6,270	*5,520	3,300				*3,690	2,830	5.15
	lb	*24,180	*24,180	*18,360	13,820	*12,170	7,280				*8,140	6,240	(16.9)

Boom : 4.6 m (15' 1") / Arm : 2.5 m (8' 2") / Bucket : 0.58 m³ (0.76 yd³) SAE heaped / Shoe : 600 mm (24") triple grouser

Load point height m (ft)	Load radius								At max. reach				
	1.5 m (5 ft)		3.0 m (10 ft)		4.5 m (15 ft)		6.0 m (20 ft)		Capacity	Reach			
6.0 m (20 ft)	kg								*2,810	2,040	6.69		
	lb								*6,190	4,500	(21.9)		
4.5 m (15 ft)	kg							*2,770	2,410	2,660	1,600	7.53	
	lb							*6,110	5,310	5,860	3,530	(24.7)	
3.0 m (10 ft)	kg			*4,930	*4,930	*3,830	3,770	*3,380	2,320	2,380	1,400	7.95	
	lb			*10,870	*10,870	*8,440	8,310	*7,450	5,110	5,250	3,090	(26.1)	
1.5 m (5 ft)	kg			*8,030	6,580	*5,010	3,490	3,680	2,210	2,300	1,340	8.03	
	lb			*17,700	14,510	*11,050	7,690	8,110	4,870	5,070	2,950	(26.3)	
Ground Line	kg			*8,780	6,140	5,640	3,280	3,570	2,110	2,400	1,400	7.77	
	lb			*19,360	13,540	12,430	7,230	7,870	4,650	5,290	3,090	(25.5)	
-1.5 m (-5 ft)	kg	*5,740	*5,740	*9,910	6,040	5,530	3,180	3,510	2,060	2,730	1,610	7.15	
	lb	*12,650	*12,650	*21,850	13,320	12,190	7,010	7,740	4,540	6,020	3,550	(23.5)	
-3.0 m (-10 ft)	kg	*8,760	*8,760	*9,040	6,110	5,550	3,200			*3,540	2,170	6.01	
	lb	*19,310	*19,310	*19,930	13,470	12,240	7,050			*7,800	4,780	(19.7)	
-4.5 m (-15 ft)	kg			*6,590	6,370								
	lb			*14,530	14,040								

Boom : 4.6 m (15' 1") / Arm : 3.0 m (9' 10") / Bucket : 0.58 m³ (0.76 yd³) SAE heaped

