

# Robex 170W-9

With Tier 3 Engine installed

\* Photo may include optional equipment.



Head Office(Sales Office)  
14F, GLOBAL R&D CENTER, 477 BUNDANG SUSEO-RO, BUNDANG-GU, SEONGNAM-SI, GYEONGGI-DO, 13553, KOREA

PLEASE CONTACT

# Pride at Work

Hyundai Construction Equipment strives to build state-of-the-art earthmoving equipment to give every operator maximum performance, more precision, versatile machine preferences, and proven quality. Take pride in your work with Hyundai!



## Robex 170w-9

### Machine Walk-Around

#### Engine Technology

Proven and reliable, fuel efficient HYUNDAI HE6.7 engine  
Electronically controlled for optimum fuel-to-air ratio and clean, efficient combustion  
Low noise / Auto engine warm up feature / Anti-restart feature

#### Hydraulic System Improvements

New patented hydraulic control system for improved controllability / Improved control valve design for added efficiency and smoother operation / New auto boom and swing priority system for optimum speed / New auto power boost feature for additional power when needed / Improved arm-in flow regeneration system for added speed and efficiency

#### Pump Compartment

Industry-leading, powerful, reliable Kawasaki designed, variable volume tandem axial piston pumps  
New compact solenoid block equipped with 4 solenoid valves, 1 EPPR valve, 1 check valve, accumulator and pilot filter - controls, power boost, boom priority, safety lock, arm-in regeneration control, creep, swing logic valve control  
Remotely mounted fuel, engine oil and case drain filters for maximum convenience while servicing

#### Improved Steering Column

Slim-profile steering column capable of telescoping 60 mm and tilting 30 degrees

#### Carrier

Heavy duty carrier frame with two speed powershift transmission  
Heavy duty drive line and axles  
Front axle oscillation +/- 7 degrees with ram lock  
Wet disc brake with no digging effect (front & rear)  
Automatic parking brake - spring applied, hydraulically released

#### Enhanced Operator Cab

##### Improved visibility

Enlarged cab with improved visibility / See-through upper skylight for visibility and ventilation  
Larger right-side glass, now one piece, for better right visibility  
Safety glass windows on all sides - less expensive than (polycarbonate) and won't scratch or fade  
Closeable sunshade for operator convenience / Reduced front window seam for improved operator view

##### Improved Cab Construction

New steel tube construction for added operator safety, protection and durability  
New window open/close mechanism designed with cable and spring lift assist and single latch release

##### Improved Suspension Seat / Console Assembly

Ergonomic joysticks with auxiliary control buttons for attachment use. Now with new sleek styling  
Heated suspension (standard) or optional air ride suspension with heat  
New joystick consoles - now adjustable in height by way of dial at bottom  
Adjustable arm rests - turn dial to raise or lower for optimum comfort

##### Advanced 7" Color Cluster

New color LCD display with easy-to-read digital gauges for hydraulic oil temperature, water temperature, and fuel  
Simplified design makes adjustment and diagnostics easier. Also, new enhanced features such as rear-view camera are integrated into monitor.

3 power modes : (P) Power, (S) Standard, (E) Economy, 2 work modes : Dig & Attachment, (U) User mode for operator preference  
Enhanced self-diagnostic features with GPS download capability

One pump flow or two pump flow for optional attachment now selectable through the cluster / New anti-theft system with password capability

Boom speed and arm regeneration are selectable through the monitor.

Auto power boost is now available - selectable (on/off) through the monitor.

Powerful air conditioning and heat with auto climate control, 20% more heat and air output than 7A series!

Hi-MATE (Remote Management System) works through GPS/Satellite technology to ultimately provide better customer service and support.

\*Photo may include optional equipment.

# Preference

Operating a 9 Series is unique to every operator. Operators can fully customize their work environment and operating preferences to fit their individual needs.



\*Photo may include optional equipment.



## Wide Cabin with Excellent Visibility

The newly designed cabin was conceived for more space, a wider field of view and operator comfort. Special attention was given to a clear, open and convenient interior with plenty of visibility on the machine surroundings and the job at hand. This well balanced combination of precision aspects put the operator in the perfect position to work safely and securely.

## Operator Comfort

In a 9 series cabin you can easily adjust the seat, console and armrest settings to best suit your preferred comfort level. Seat and console position and height can be set together and independent from each other. Improved steering wheel telescope and tilt functions provide operators improved access. A fully automatic, high capacity airconditioning system maintains a constant preferred temperature. During cold weather conditions, the PTC cab heater provides immediate heat at startup for added operator comfort.



## Reduced Stress

Work is stressful enough. Your work environment should be stress free. Hyundai's 9 series provides improved cab amenities, additional space and a comfortable seat to minimize stress to the operator. A powerful climate control system provides the operator with optimum air temperature. An advanced audio system with USB player, AM/FM stereo and MP3 capabilities, plus remotely located controls is perfect for listening to music favorites. Operators can even talk on the phone with the hands-free cell phone feature.



## Operator - Friendly Cluster

The advanced new cluster with 7 inch wide color LCD screen and toggle switch allows the operator to select his personal machine preferences. Power and work mode selection, self diagnostics, rear-view camera, maintenance check lists, start-up machine security, and video functions were integrated into the cluster to make the machine more versatile and the operator more productive.



# Precision

Innovative hydraulic system technologies make the 9 Series excavator fast, smooth and easy to control.



\*Photo may include optional equipment.

## Computer Aided Power

The engine horsepower and hydraulic horsepower work together in unison through the advanced CAPO(Computer Aided Power Optimization) system.

This system interfaces with multiple sensors placed throughout the hydraulic system, as well as the electronically controlled engine, to provide the optimum level of engine power and hydraulic flow for the job at hand.

Operators can set their own preferences for boom or swing priority, power mode selection and optional work tools at the touch of a button. The CAPO system also provides complete self diagnostic features and digital gauges for important information like hydraulic oil temperature, water temperature and fuel level.

### Power Mode

Three unique power modes provide the operator with custom power, speed and fuel economy.

P (Power Max) mode maximizes machine speed and power for mass production.

S (Standard) mode provides a reduced, fixed rpm for optimum performance and improved fuel economy. For maximum fuel savings and improved control, E (Economy) mode provides precise flow and engine power based on load demand.

### Work Mode

The work mode allows the operator to select single flow attachments like a hydraulic breaker or bi-directional flow attachments like a crusher. Flow settings unique to each attachment can be programmed from within the cluster.

### User Mode

Some jobs require more precise machine settings. Using the versatile U (User) mode, the operator can customize engine speed, pump output, idle speed and other machine settings according to personal preferences.

## Improved Hydraulic System



To achieve optimum precision, Hyundai redesigned the hydraulic system to provide the operator with super fine touch and improved controllability. Improved pump flow control reduces flow when controls are not being used to minimize fuel consumption.

Improved spool valves in the control valve are engineered to provide more precise flow to each function with less effort.

Improved hydraulic valves, precision-designed variable volume piston pumps, fine-touch pilot controls, and enhanced travel functions make any operator running a 9

series look like a smooth operator. Newly improved features include arm-in and boom-down flow regeneration, improved control valve technology and innovative auto boom and swing priority for optimal performance in any application.



## Auto Boom-swing Priority

This smart function automatically and continuously looks for the ideal hydraulic flow balance for the boom and swing functions of the machine. The advanced CAPO system monitors the hydraulic system and adjusts its settings to maximize performance and productivity.

# Performance

9 Series is designed for maximum performance to keep the operator working productively.



## Fully Independent Outrigger System

R170W-9 can be equipped with four independent outriggers (front and rear) or two independent outriggers and a dozer blade (front or rear). Each outrigger and the dozer blade are controlled by a switch and the dozer lever. Each outrigger is equipped with cylinder guards for added protection.

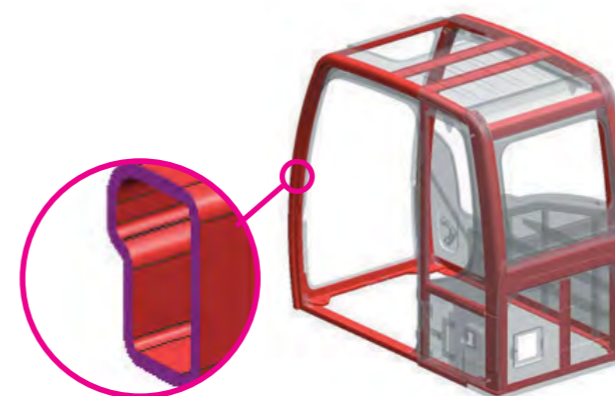

## Structural Strength

The 9 series cabin structure has been fitted with stronger but slimmer tubing for more safety and better visibility. Low-stress and high strength steel was integrally welded to form a strong and stable lower frame. Structural durability was evaluated and tested by means of FEM (Finite Elements Method) analysis and long-term durability tests.

## New and Improved Travel System

Auto cruise control system reduces operator fatigue by maintaining a fixed speed when driving distances. A new auto ram lock system is available to improve operating safety. A new creep speed travel system improves maneuverability and fine control. A new optional forward / reverse travel pedal control allows operators to choose to use the travel pedal control while in work mode or lever control when in travel mode.



Auto cruise control system    Auto ram lock system    Creep speed travel system



## HYUNDAI HE 6.7 ENGINE

The Tier III, six cylinder, 4 cycle, turbo-charged, charge air cooled, HYUNDAI HE 6.7 engine provides maximum power, reliability, optimum fuel economy, and reduced emissions. Electronically controlled fuel injection and diagnostic capabilities add to the engine's efficiency and serviceability.

\*Photo may include optional equipment.

# Profitability

9 Series is designed to maximize profitability through improved efficiencies, enhanced service features and longer life components.



\*Photo may include optional equipment.

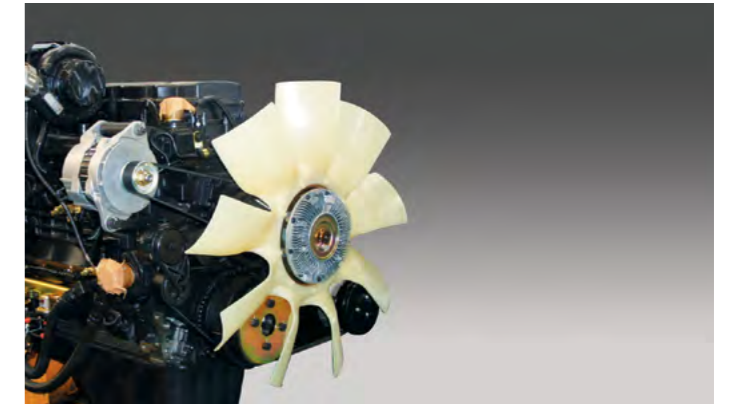

## Fuel Efficiency

9 series excavators are engineered to be extremely fuel efficient. New innovations like the variable speed fan clutch, overload prevention control, two-stage auto decel system, and the new economy mode, conserve fuel and reduce the impact on the environment.



## Hi-MATE (Remote Management System)

Hi-MATE, Hyundai's proprietary remote management system, provides operators and dealer service personnel access to vital service and diagnostic information on the machine from any computer with internet access. Users can pinpoint machine location using digital mapping and set machine work boundaries, reducing the need for multiple service calls. Hi-MATE saves time and money for the owner and dealer by promoting preventative maintenance and reducing machine downtime.



## Easy Access

Ground-line access to filters, lube fittings, fuses, machine computer components and wide open compartments makes service more convenient on the 9S Series.



## Long-Life Components

9 series excavators were designed with bushings designed for long-life lube intervals (250 hrs) & polymer shims (wear resistant, noise reducing), long-life hydraulic filters (1,000hrs), long-life hydraulic oil (5,000hrs), more efficient cooling systems and integrated preheating systems which extend service intervals, minimize operating costs and reduce machine down time.

# Specifications

## ENGINE

MODEL	HYUNDAI HE6.7		
Type	Water-cooled, 4-cycle diesel, 6-cylinder in-line, Direct injection, Turbocharged, Charge air cooled, Low emission		
Rated flywheel horsepower	SAE	J1995 (gross)	163 HP (122kW) at 2,100 rpm
		J1349 (net)	153 HP (114kW) at 2,100 rpm
	DIN	6271/1 (gross)	165 PS (122kW) at 2,100 rpm
		6271/1 (net)	155 PS (114kW) at 2,100 rpm
Max. torque	75 kgf·m(542 lbf·ft) at 1,400 rpm		
Bore X stroke	107 x 124 mm (4.21" x 4.88")		
Piston displacement	6,700 cc (409 in <sup>3</sup> )		
Batteries	2 x 12 V x 100 AH		
Starting motor	24V-4.5kW		
Alternator	24V-70 Amp		

## HYDRAULIC SYSTEM

MAIN PUMP	
Type	Two variable displacement piston pumps
Rated flow	2 X 168 L /min (44.4 US gpm/37 UK gpm)
Sub-pump for pilot circuit	Gear pump

Cross-sensing and fuel saving pump system

HYDRAULIC MOTORS	
Travel	Two-speed axial pistons motor with brake valve and parking brake
Swing	Axial piston motor with automatic brake

RELIEF VALVE SETTING	
Implement circuits	350 kgf/cm <sup>2</sup> (4,970 psi)
Travel	380 kgf/cm <sup>2</sup> (5,400 psi)
Power boost (boom, arm, bucket)	380 kgf/cm <sup>2</sup> (5,400 psi)
Swing circuit	285 kgf/cm <sup>2</sup> (4,050 psi)
Pilot circuit	40 kgf/cm <sup>2</sup> (570 psi)
Service valve	installed

HYDRAULIC CYLINDERS	
No. of cylinder bore X stroke	Boom : 2-115 x 1090 mm (4.5" x 42.9")
	Arm : 1-120 x 1355 mm (4.7" x 53.3")
	Bucket : 1-110 x 995 mm (4.3" x 39.2")
	Blade : 2-110 x 235 mm (4.3" x 9.3")
	Outrigger : 2-125 x 463 mm (4.9" x 18.2")
	2-PCS boom : 2-115 x 960 mm (4.1" x 37.8")
	Adjust(boom) : 1-160 x 650 mm (6.3" x 25.6")

## DRIVES & BRAKES

4-wheel hydrostatic drive. Constant mesh, helical gear transmission provides 2 forward and reverse travel speeds.

Max. drawbar pull	11,000 kgf (24,250 lbf)	
Travel speed	1st	10 km/h
	2nd	36 km/h
Gradeability	35°(70 %)	

Service Brake :  
 - Independent dual brake, front and rear axle full hydraulic power brake.  
 - Spring released and hydraulic applied wet type multiple disc brake.  
 Parking Brake :  
 - Spring applied and hydraulic released wet disc brake type in transmission.

## CONTROL

Pilot pressure operated joysticks and pedals with detachable lever provide almost effortless and fatigueless operation.

Pilot control	Two joysticks with one safety lever (LH): Swing and arm, (RH): Boom and bucket (ISO)
Engine throttle	Electric, Dial type

## AXLE & WHEEL

Full floating front axle is supported by center pin for ocillation. It can be locked by ocillation lock cylinders. Rear axle is fixed on the lower chassis.

Tires	10.00-20-14PR, Dual(tube type)
(optional)	10.00-20, Dual(solid type)

## SWING SYSTEM

Swing motor	Fixed displacement axial pistons motor
Swing reduction	Planetary gear reduction
Swing bearing lubrication	Grease-bathed
Swing brake (option)	Multi wet disc (pin lock type)
Swing speed	11 rpm

## STEERING SYSTEM

Hydraulically actuated, orbitrol type steering system actuates on front wheels through the steering cylinders.

Min. turning radius	6,300 mm (20' 8")
---------------------	-------------------

## COOLANT & LUBRICANT CAPACITY

Refilling	liter	US gal	UK gal	
Fuel tank	270	71.3	59.4	
Engine coolant	19.5	5.2	4.3	
Engine oil	24	6.3	5.3	
Swing device - gear oil	5	1.3	1.1	
Axle	Front	15.5	4.1	3.4
	Rear	17.5	4.6	3.9
Hydraulic system (including tank)	270	71.3	59.4	
Hydraulic tank	160	42.3	35.2	

## UNDERCARRIAGE

Reinforced box-section frame is all-welded, low-stress. Dozer blade and outriggers are available. A pin-on design.

Dozer blade	A very useful addition for leveling and back filling or clean-up work.
Outrigger	Indicated for max. operation stability when digging and lifting. Can be mounted on the front/or the rear.

## OPERATING WEIGHT (APPROXIMATE)

Operating weight, including 5,100mm (16' 9") Mono boom, 2,200mm (7' 3") arm, SAE heaped 0.76m<sup>3</sup> (0.99yd<sup>3</sup>) backhoe bucket, lubricant, coolant, full fuel tank, hydraulic tank and the standard equipment.

MAJOR COMPONENT WEIGHT	
Upperstructure	4,590kg (10,120 lb)
Mono boom(with arm cylinder)	1,240kg (2,730 lb)
Hydraulic adjustable boom (with adjust cylinder and arm cylinder)	1,780kg (3,920 lb)

OPERATING WEIGHT		
Undercarriage	Mono boom	Hyd. adjustable boom
Rear dozer blade	17,300 (38,140)	17,770 (39,180)
Rear outrigger	17,450 (38,470)	17,920 (39,510)
Front outrigger and rear blade	18,420 (40,610)	18,890 (41,650)
Front blade and rear outrigger	18,360 (40,480)	18,830 (41,510)
Four outrigger	18,600 (41,010)	19,070 (42,040)

## AIR CONDITIONING SYSTEM

The air condition system for the machine contains the fluorinated greenhouse gas with global warming potential of R134a. (Global Warming Potential : 1430)

The system hold 0.75kg refrigerant consisting of a CO<sub>2</sub> equivalent 1.07kg metric tonne. For more information, Please refer to the manual.

## BUCKETS

All buckets are welded with high-strength steel.



SAE heaped m<sup>3</sup> (yd<sup>3</sup>)

Capacity m <sup>3</sup> (yd <sup>3</sup> )		Width mm (in)		Weight kg (lb)	Recommendation mm (ft-in)				
SAE heaped	CECE heaped	Without sidecutters	With sidecutters		5,100 (16' 9") Mono Boom			5,100 (16' 1") Hydraulic Adjustable Boom	
					2,200 (7' 3") Arm	2,600 (8' 6") Arm	3,100 (10' 2") Arm	2,200 (7' 3") Arm	2,600 (8' 6") Arm
0.39 (0.51)	0.34(0.44)	620(24.4)	740(29.1)	410(900)	●	●	●	●	●
0.50 (0.65)	0.44(0.58)	760(29.9)	880(34.6)	470(1040)	●	●	■	●	●
0.64 (0.84)	0.55(0.72)	920(36.2)	1,040(40.9)	510(1120)	●	●	■	●	■
0.76 (0.99)	0.65(0.85)	1,060(41.7)	1,180(46.5)	570(1260)	●	■	■	●	■
0.89 (1.16)	0.77(1.01)	1,220(48.0)	1,340(52.8)	610(1340)	■	▲	-	■	▲
1.05 (1.37)	0.90(1.18)	1,400(55.1)	1,520(59.8)	680(1500)	▲	-	-	▲	-
○ 0.69 (0.90)	0.62(0.81)	990(39.0)	-	700(1540)	●	▲	▲	■	▲

○ Heavy duty bucket

●: Applicable for materials with density of 2,000 kg /m<sup>3</sup> (3,370 lb/ yd<sup>3</sup>) or less  
 ■: Applicable for materials with density of 1,600 kg /m<sup>3</sup> (2,700 lb/ yd<sup>3</sup>) or less  
 ▲: Applicable for materials with density of 1,100 kg /m<sup>3</sup> (1,850 lb/ yd<sup>3</sup>) or less

## ATTACHMENT

Booms and arms are welded with a low-stress, full-box section design. 5.1m (16' 9") boom, 5.1m (16' 1") Hydraulic Adjustable Boom and 2.2m (7' 3"), 2.6m (8' 6"), 3.1m (10' 2") arms.

## DIGGING FORCE

Boom	Length	mm (ft-in)	5,100 (16' 9")			Remarks
	Weight	kg (lb)	1,240 (2,730)			
Arm	Length	mm (ft-in)	2,200 (7' 3")	2,600 (8' 6")	3,100 (10' 2")	Remarks
	Weight	kg (lb)	750 (1,560)	810 (1,790)	890 (1,960)	
Bucket digging force	SAE	kN	107.9 [117.2]	107.9 [117.2]	107.9 [117.2]	[ ]: Power Boost
		kgf	11,000 [11,940]	11,000 [11,940]	11,000 [11,940]	
		lbf	24,250 [26,330]	24,250 [26,330]	24,250 [26,330]	
	ISO	kN	123.6 [134.2]	123.6 [134.2]	123.6 [134.2]	
		kgf	12,600 [13,680]	12,600 [13,680]	12,600 [13,680]	
		lbf	27,780 [30,160]	27,780 [30,160]	27,780 [30,160]	
Arm crowd force	SAE	kN	87.2 [94.7]	77.3 [83.9]	69.0 [74.9]	
		kgf	8,890 [9,650]	7,880 [8,560]	7,030 [7,630]	
		lbf	19,600 [21,280]	17,270 [18,860]	15,500 [16,830]	
	ISO	kN	91.0 [98.8]	80.3 [87.2]	71.4 [77.5]	
		kgf	9,280 [10,080]	8,190 [8,890]	7,280 [7,900]	
		lbf	20,460 [22,210]	18,060 [19,600]	16,050 [17,430]	

Note: Boom weight includes arm cylinder, piping, and pin  
 Arm weight includes bucket cylinder, linkage, and pin

# Dimensions & Working Range

## R170W-9 DIMENSIONS

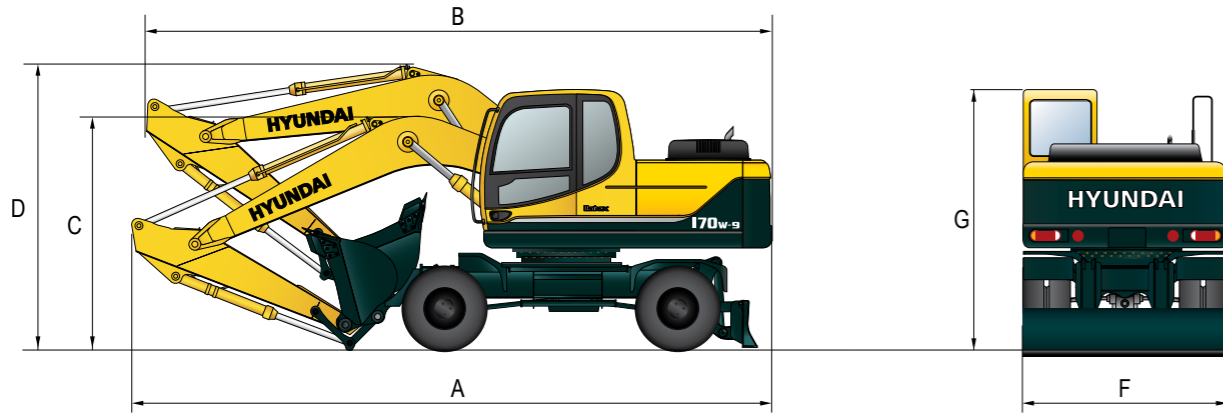

Unit : mm (ft-in)

	5,100 (16' 9")		
Mono Boom			
Arm	2,200 (7' 3")	2,600 (8' 6")	3,100 (11' 1")
A Overall length of shipping position	8,650 (28' 5")	8,730 (28' 8")	8,760 (28' 9")
B Overall length of traveling position	8,590 (28' 2")	8,400 (27' 7")	8,480 (27' 10")
C Height of attachment(shipping position)	3,060 (10' 0")	3,020 (9' 11")	3,150 (10' 4")
D Height of attachment(traveling position)	3,610 (11' 10")	3,940 (12' 11")	3,900 (12' 10")
F Overall width	2,500 (8' 2")	2,500 (8' 2")	2,500 (8' 2")
G Height of cabin	3,190 (10' 6")	3,190 (10' 6")	3,190 (10' 6")

## R170W-9 WORKING RANGE

Unit : mm (ft-in)

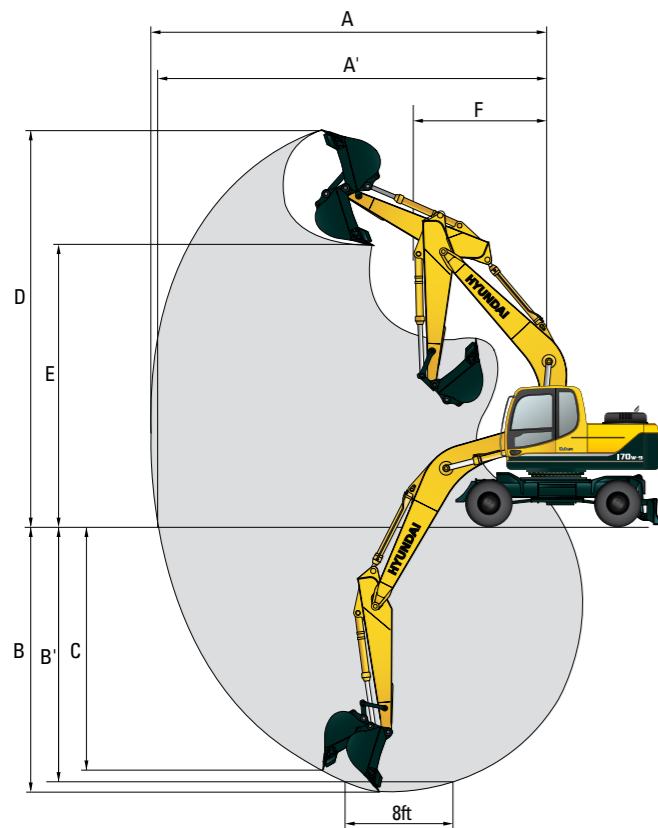

	5,100 (16' 9")		
Boom length			
Arm length	2,200 (7' 3")	2,600 (8' 6")	3,100 (10' 2")
A Max. digging reach	8,690 (28' 6")	9,020 (29' 7")	9,450 (31' 0")
A' Max. digging reach on ground	8,480 (27' 10")	8,810 (28' 11")	9,250 (30' 4")
B Max. digging depth	5,420 (17' 9")	5,820 (19' 1")	6,320 (20' 9")
B' Max. digging depth (8' level)	5,200 (17' 1")	5,620 (18' 5")	6,130 (20' 1")
C Max. vertical wall digging depth	4,890 (16' 1")	5,140 (16' 10")	5,470 (17' 11")
D Max. digging height	8,990 (29' 6")	9,070 (29' 9")	9,220 (30' 3")
E Max. dumping height	6,350 (20' 10")	6,460 (21' 2")	6,620 (21' 9")
F Min. swing radius	3,180 (10' 5")	3,170 (10' 5")	3,160 (10' 4")

## R170W-9 ADJUSTABLE BOOM

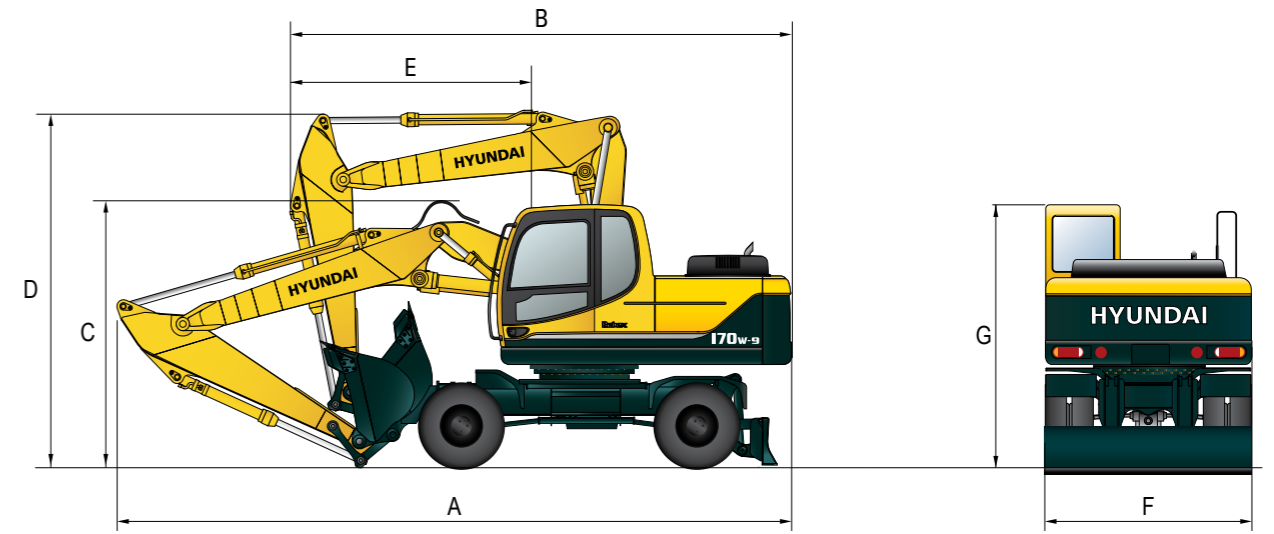

Unit : mm (ft-in)

	5,100 (16' 9")	
Hydraulic adjustable Boom		
Arm	2,200 (7' 3")	2,600 (8' 6")
A Overall length of shipping position	8,650 (28' 5")	8,750 (28' 8")
B Overall length of traveling position	6,630 (21' 9")	6,620 (21' 9")
C Height of attachment(shipping position)	2,900 (9' 6")	2,920 (9' 7")
D Height of attachment(traveling position)	3,980 (13' 1")	3,960 (13' 0")
E End of attachment to steering wheel	3,300 (10' 10")	3,290 (10' 10")
F Overall width	2,500 (8' 2")	2,500 (8' 2")
G Height of cabin	3,190 (10' 6")	3,190 (10' 6")

## R170W-9 ADJUSTABLE BOOM WORKING RANGE

Unit : mm (ft-in)

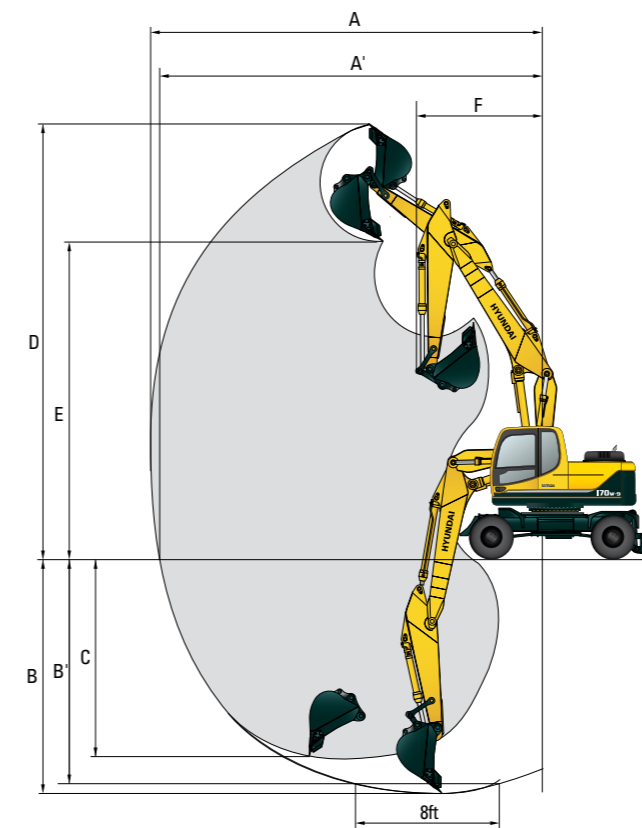

	5,100 (16' 9")	
Boom length		
Arm length	2,200 (7' 3")	2,600 (8' 6")
A Max. digging reach	8,760 (28' 9")	9,110 (29' 11")
A' Max. digging reach on ground	8,550 (28' 1")	8,910 (29' 3")
B Max. digging depth	5,220 (17' 2")	5,620 (18' 5")
B' Max. digging depth (8' level)	5,120 (16' 10")	5,520 (18' 1")
C Max. vertical wall digging depth	4,430 (14' 6")	4,780 (15' 8")
D Max. digging height	9,630 (31' 7")	9,820 (32' 3")
E Max. dumping height	6,930 (22' 9")	7,130 (23' 5")
F Min. swing radius	3,100 (10' 2")	2,970 (9' 9")

# Undercarriage

# Lifting Capacity

Rating over-front Rating over-side or 360 degree

**R170W-9 WITH REAR DOZER AND FRONT REST**

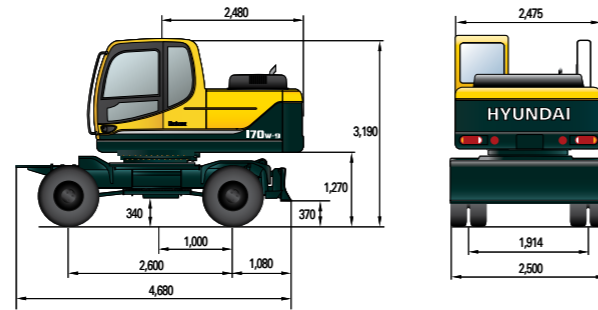

**R170W-9 WITH REAR OUTRIGGER AND FRONT REST**

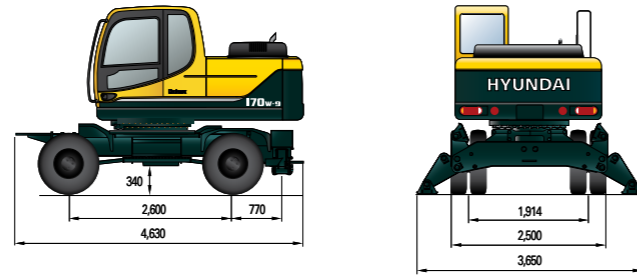

**R170W-9 WITH REAR DOZER AND FRONT OUTRIGGER**

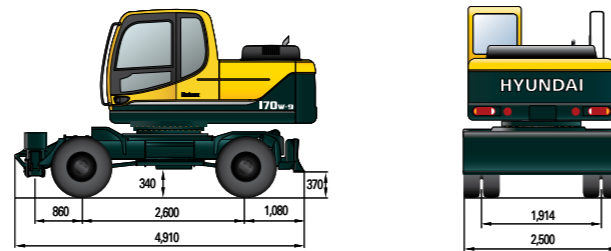

**R170W-9 WITH REAR AND FRONT OUTRIGGER**

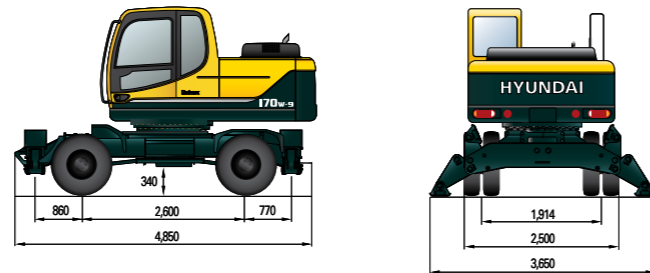

**R170W-9 WITH REAR OUTRIGGER AND FRONT DOZER**

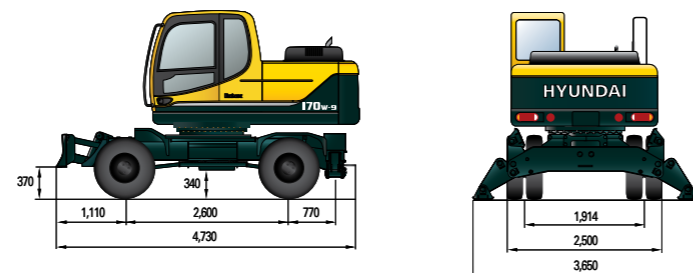

## R170W-9 MONO BOOM

Boom : 5.1 m (16' 9") / Arm : 2.2 m (7' 3") / Bucket : 0.76 m<sup>3</sup> (0.99 yd<sup>3</sup>) SAE heaped / With rear dozer blade down

Load point height m (ft)	Load radius								At max. reach		
	1.5 m (5 ft)		3.0 m (10 ft)		4.5 m (15 ft)		6.0 m (20 ft)		Capacity		Reach m (ft)
7.5 m (25 ft)	kg								*3710	3020	5.89 (19.3)
	lb								*8180	6660	
6.0 m (20 ft)	kg						*3340	2830	*3660	2080	7.15 (23.5)
	lb						*7360	6240	*8070	4590	
4.5 m (15 ft)	kg				*4730	4550	*4170	2770	*3690	1680	7.86 (25.8)
	lb				*10430	10030	*9190	6110	*8140	3700	
3.0 m (10 ft)	kg		*9740	7880	*6000	4190	*4690	2630	3430	1500	8.19 (26.9)
	lb		*21470	17370	*13230	9240	*10340	5800	7560	3310	
1.5 m (5 ft)	kg				*7180	3850	*5230	2470	3380	1460	8.19 (26.9)
	lb				*15830	8490	*11530	5450	7450	3220	
Ground	kg		*7660	6950	*7720	3660	5520	2360	3580	1540	7.87 (25.8)
	lb		*16890	15320	*17020	8070	12170	5200	7890	3400	
-1.5 m (-5 ft)	kg	*7650	*7650	*11110	7010	*7510	3620	*5380	2330	*3950	1820 (7.18)
	lb	*16870	*16870	*24490	15450	*16560	7980	*11860	5140	*8710	4010 (23.6)
-3.0 m (-10 ft)	kg	*12010	*12010	*9250	7190	*6410	3700			*3660	2540 (5.95)
	lb	*26480	*26480	*20390	15850	*14130	8160			*8070	5600 (19.5)

Boom : 5.1 m (16' 9") / arm : 2.6 m (8' 6") / Bucket : 0.76 m<sup>3</sup> (0.99 yd<sup>3</sup>) SaE heaped / With rear dozer blade down

Load point height m (ft)	Load radius								At max. reach				
	1.5 m (5 ft)		3.0 m (10 ft)		4.5 m (15 ft)		6.0 m (20 ft)		7.5 m (25 ft)		Capacity		Reach m (ft)
7.5 m (25 ft)	kg										*3360	2640	6.37 (20.9)
	lb										*7410	5820	
6.0 m (20 ft)	kg						*3250	2870			*3360	1880	7.53 (24.7)
	lb						*7170	6330			*7410	4140	
4.5 m (15 ft)	kg						*3830	2790			*3420	1530	8.20 (26.9)
	lb						*8440	6150			*7540	3370	
3.0 m (10 ft)	kg		*8540	8180	*5530	4240	*4400	2630	*2990	1740	3190	1370	8.52 (28.0)
	lb		*18830	18030	*12190	9350	*9700	5800	*6590	3840	7030	3020	
1.5 m (5 ft)	kg		*7620	7180	*6830	3860	*5010	2460	*3710	1660	3140	1330	8.52 (28.0)
	lb		*16800	15830	*15060	8510	*11050	5420	*8180	3660	6920	2930	
Ground	kg		*8230	6890	*5750	3630	*5420	2330	*3250	1610	3300	1390	8.22 (27.0)
	lb		*18140	15190	*12690	8000	*11950	5140	*7170	3550	7280	3060	
-1.5 m (-5 ft)	kg	*7190	*7190	*11280	6890	*7570	3550	5420	2270		3780	1620	7.56 (24.8)
	lb	*15850	*15850	*24870	15190	*16690	7830	11950	5000		8330	3570	
-3.0 m (-10 ft)	kg	*10590	*10590	*9950	7030	*6760	3590	*4660	2320		*3700	2180	6.43 (21.1)
	lb	*23350	*23350	*21940	15500	*14900	7910	*10270	5110		*8160	4810	
-4.5 m (-15 ft)	kg			*6800	*6800								
	lb			*14990	*14990								

Boom : 5.1 m (16' 9") / arm : 2.6 m (8' 6") / Bucket : 0.76 m<sup>3</sup> (0.99 yd<sup>3</sup>) SaE heaped / With rear dozer blade down

Load point height m (ft)	Load radius								At max. reach				
	1.5 m (5 ft)		3.0 m (10 ft)		4.5 m (15 ft)		6.0 m (20 ft)		7.5 m (25 ft)		Capacity		Reach m (ft)
7.5 m (25 ft)	kg										*3000	2250	6.96 (22.8)
	lb										*6610	4960	
6.0 m (20 ft)	kg						*2970	2920			*3030	1650	8.02 (26.3)
	lb						*6550	6440			*6680	3640	
4.5 m (15 ft)	kg						*3420	2820	*2310	1810	*3110	1360	8.65 (28.4)
	lb						*7540	6220	*5090	3990	*6860	3000	
3.0 m (10 ft)	kg			*7140	*7140	*4940	4320	*4030	2650	*3220	1740	2910	1220 (8.95)
	lb			*15740	*15740	*10890	9520	*8880	5840	*7100	3840	6420	2690 (29.4)
1.5 m (5 ft)	kg			*10650	7380	*6370	3910	*4720	2450	3850	1640	2860	1170 (8.95)
	lb			*23480	16270	*14040	8620	*10410	5400	8490	3620	6310	2580 (29.4)
Ground	kg	*4330	*4330	*8780	6880	*7320	3620	*5240	2300	3760	1570	2990	1220 (8.67)
	lb	*9550	*9550	*19360	15170	*16140	7980	*11550	5070	8290	3460	6590	2690 (28.4)
-1.5 m (-5 ft)	kg	*6700	*6700	*10760	6780	*7570	3490	5360	2210		3360	1400	8.05 (26.4)
	lb	*14770	*14770	*23720	14950	*16690	7690	11820	4870		7410	3090	
-3.0 m (-10 ft)	kg	*9430	*9430	*10640	6870	*7070	3490	*4990	2220		*3620	1820	7.01 (23.0)
	lb	*20790	*20790	*23460	15150	*15590	7690	*11000	4890		*7980	4010	
-4.5 m (-15 ft)	kg	*13120	*13120	*8110	7120	*5400	3640				*3220	3090	5.23 (17.2)
	lb	*28920	*28920	*17880	15700	*11900	8020				*7100	6810	

- Lifting capacity is based on ISO 10567.
- Lifting capacity of the Robex Series does not exceed 75% of the tipping load with the machine on firm, level ground or 87% of full hydraulic capacity.
- The load point is a hook located on the back of the bucket.
- (\*) indicates the load limited by hydraulic capacity.

