

# HX1000A L

Crawler Excavators

\* Photo may include optional equipment.



Head Office(Sales Office)  
14F, GLOBAL R&D CENTER, 477 BUNDANG SUSEO-RO, BUNDANG-GU, SEONGNAM-SI, GYEONGGI-DO, 13553, KOREA

PLEASE CONTACT

Rated power  
629 hp (469 kW) @ 2,000 rpm

Bucket capacity  
5.4 ~ 6.8 m<sup>3</sup>

Operating Weight  
97.9 ~ 100.2 t

# HYUNDAI HX1000A L CRAWLER EXCAVATOR MADE FOR THE TOUGHEST APPLICATIONS

Lift your business to the next level with the HX1000A L HYUNDAI excavator.

Strong undercarriage, and the highest engine power and hydraulic flow in the market, with total control of the fuel consumption, to offer the lowest possible cost per ton.



\* Photo may include optional equipment.

# WHAT'S NEWEST AND BEST

## HX1000AL

### HIGH PRODUCTIVITY AND LOW COST OF OWNERSHIP

Delivers higher productivity and reduced fuel consumption in an efficient and comfortable work environment.

### RELIABILITY

Designed for the toughest applications and the most abrasive materials.

### SAFETY

Your safety is our priority: 360° camera system, large side mirrors, powerful LED work lights, anti-slip steps and platforms, guard rails on upper structure.

### MASS EXCAVATION

2 Heavy Duty (HD) front combinations available to match various conditions. Mass excavation front with large bucket size or heavy-duty fronts when long reach is needed.

### SWING BEARINGS

Unique design of crossed bearings, for better stress distribution, and increased lifetime.

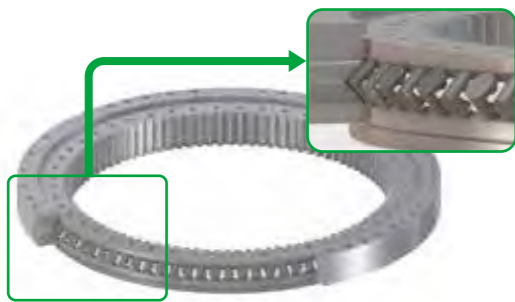

### UNDERCARRIAGE DURABILITY

Heavy-duty undercarriage, with large rollers and sprocket, enhanced frame for the toughest applications

### EASY MAINTENANCE

Automatic greasing system as standard, all filters easily accessible, compressor with air gun as option, everything designed for easy maintenance.

### ADVANCED FILTRATION

Highest efficiency filters & cleaners remove water, dust & particles to protect your investment optimally.

### COMFORT

One of the most spacious cabs in the market, with low noise & vibration levels and excellent all-round visibility. Fully adjustable heated air-suspension seat, air conditioning with climate control as standard.

### OPERATE AT EASE

All important information is at your fingertips with the new easy-to-use 8" touch screen. Exclusive jog shuttle switch, 4 work & 4 power modes, proportional control.

### ENGINE

Exceptionally powerful – with high torque at low revs – the Perkins 2806J engine combines reliability and low environmental impact. This Stage V compliant 6-cylinder engine delivers 469 kW at 2,000 rpm.

### EXCELLENT FUEL EFFICIENCY

The Smart Power Control (SPC) system increases fuel efficiency by adjusting the power to meet the application's needs. The system delivers the exact amount of oil needed to avoid any loss of energy.



\* Photo may include optional equipment.

# THE BEST PRODUCTIVITY AND FUEL EFFICIENCY

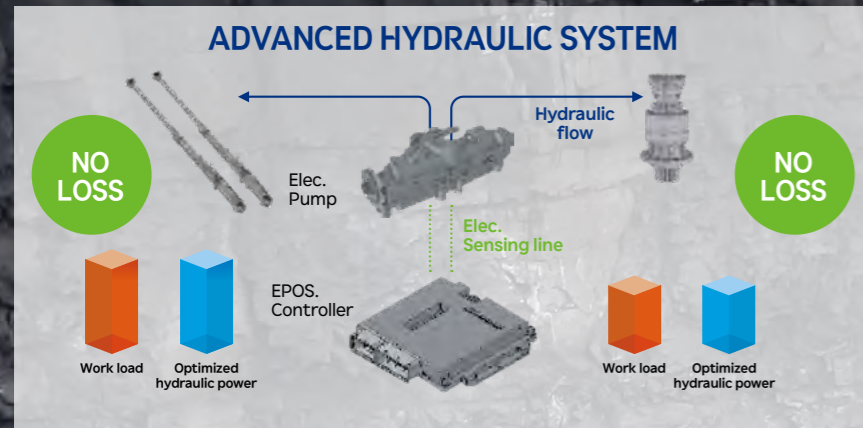
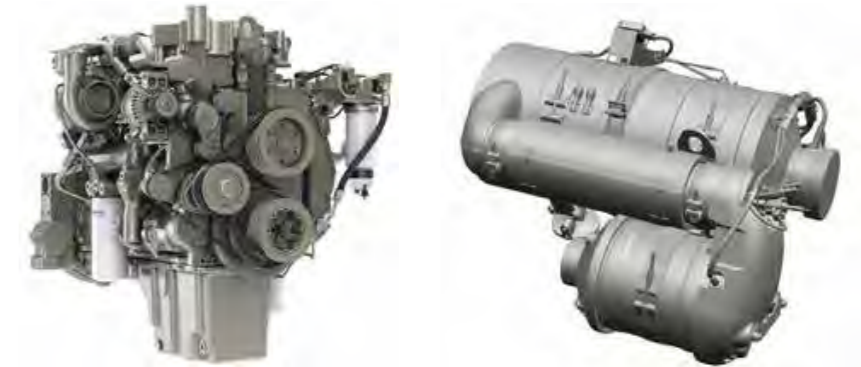

Photo may include optional equipment.

## The power to raise productivity

- The HX1000AL is equipped with the latest generation of Perkins engine
- Stage V compliant, this engine boasts extremely low emissions because reducing our environmental impact is paramount to us
- Exhaust gases are purified by Selective Catalytic Reduction (SCR) technology, a Diesel Oxidation Catalyst (DOC) and a Diesel Particulate Filter (DPF)



## Efficient Fuel Management

- Choice of 4 power modes and 4 working modes guarantees optimum performance in all conditions
- Smart Power Control (SPC3) system: reduces engine speed and adjusts pump torque according to work conditions. The system automatically adjusts engine power and hydraulic output to improve fuel efficiency and reduce emissions. 2 systems (Variable Speed Control and Pump Torque Control) work together to improve efficiency while maintaining productivity.
- Engine auto-shut-off: shuts down the engine after the machine has been idling for a specified time. The operator can set the delay before shut-off via the touchscreen

## Asymmetric Turbocharger

High-efficiency asymmetric turbocharger uses a design with 2 different sized scrolls to stream exhaust across the turbine wheel at different velocities.

## The most Advanced Hydraulic System

This new electronic main pump accurately calculates the amount of pump flow required for each actuator, thereby maximizing productivity (faster operation) and avoiding unnecessary fuel loss.

# NEW EXTERIOR DESIGN FOR ROBUSTNESS AND SAFETY



\* Photo may include optional equipment.

# RELIABILITY

In your profession, you need equipment you can depend on. At HYUNDAI, we put durability and reliability at the core of our machines' development. Our materials and structures undergo stringent testing for strength and resilience under the most extreme conditions.

### QUALITY-PROVEN MAIN COMPONENTS

Manufactured with the finest quality main components customized precisely for large equipment, this new machine offers Best-in-Class power and durability.

### STRUCTURE

HYUNDAI offers a whole new structure designed specifically for mining operations, keeping your excavator running at all times in rugged harsh environments.

### HEAVY-DUTY FRONT

The boom and arm have been specially developed for the toughest applications, such as quarrying or mass excavation, which considerably enhances the overall durability of the machine.

### CROSSED ROLLER SWING BEARINGS

Unique crossed bearing design provides longer lifetime by distributing stress more evenly.

### UNDERCARRIAGE

Our heavy-duty undercarriage further increases the durability of your machine.

### HEAVY-DUTY SPROCKET

Our heavy-duty sprocket further increases your machine's durability.

### BOOM

- Boom foot design to increase the pin strength and decrease one-sided wear of pin.
- Flat steel plate for dispersing machine stress.
- Welding design to increase welding part lifetime.
- Inner reinforced plate changed to disperse stress.

### ARM

- Bottom steel plate to increase strength of arm structure.
- Arm center boss to lower stress.
- Arm welding design to decrease stress.



Protected hydraulic system



Heavy-duty under cover



Frame



Crossed roller swing bearings



Undercarriage

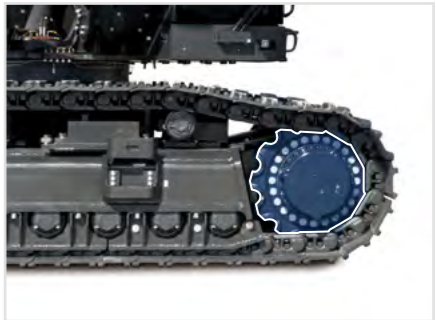

Heavy-duty sprocket

1. 8" touch screen
2. Cup holder
3. Joysticks and switches are integrated in adjustable control consoles
4. Improved visibility on the bottom right
5. Separate seat height adjustment lever and cushion tilting function
6. Straight ergonomic pedals
7. Flat, spacious, easy-to-clean floor



\* Photo may include optional equipment.

# EASY CONTROL

## BEST-IN-CLASS OPERATOR ENVIRONMENT

The HX1000AL is designed to provide you with the best possible working conditions. The sophisticated state-of-the-art cab is pressurized and compliant with level 2 FOPS protection when equipped with FOPS guard for your safety. A high-quality heated seat with air suspension provides maximum operator comfort.

## CAB SUSPENSION

The cab's suspension system (CabSus mount) dampens vibrations and provides outstanding protection against impact. This system absorbs shocks and vibrations much more effectively than a conventional silentblock suspension system.

## HYUNDAI SMART TOUCH

The wide 8" touchscreen provides easy scrolling through the different menus, including power settings and auxiliary hydraulics settings. It also allows you to connect a Bluetooth device or listen to your favorite radio station.

## 360° ALL-AROUND VIEW CAMERA (AVM) SYSTEM

The 360° camera system gives you full view of the machine's surroundings.

## HYUNDAI SMART KEY

- We bring automotive standards and comfort to construction machinery
- Search function
  - Coming/leaving home light function
  - Remote door opening
  - Keyless engine start

## ERGONOMICALLY DESIGNED PEDALS

Ergonomically designed travel pedals placed in the middle. Pedal angle adjusted to relieve pressure on ankle and joints, reducing fatigue and lightening the operator's load.



# COMFORTABLE OPERATION

The ergonomic controls and the easy-to-view color monitor place the machine firmly in your hands.



1. HYUNDAI Smart Key
2. Shear buttons
3. Breaker/booster button
4. Starter switch (Start/Stop button)
5. Engine speed control dial
6. Travel speed selector switch
7. Light switch
8. Cab work light switch
9. After-treatment system switch
10. Bluetooth control panel
11. Air conditioning and heating control panel

\* Photo may include optional equipment.

## DYNAMIC POWER MANAGEMENT

- Automatic travel speed range selection (slow/fast)
- A one-touch deceleration button immediately reduces engine speed to low idle
- Auto-idling starts 4 seconds (adjustable) after all controls are returned to neutral – reducing fuel consumption and noise levels in the cab



## "BREAKER ASSIST" MODE

During boom down operation, the boom moves down freely under its own weight. The result is reduced shock and vibration and longer breaker service life

## EXPERT FINGERTIP CONTROL

- The new multi-function 8" touchscreen displays all useful information in a visual and intuitive format
- At a glance, you can check the machine's status and settings to achieve optimal efficiency
- HYUNDAI's unique jog shuttle switch gives you easy and precise control over all machine functions
- Highly sensitive and low-effort joysticks enable you to work safely, smoothly and confidently
- The proportional thumb switches on the joysticks can be mounted horizontally or vertically, as the operator prefers, for optimal control of hydraulic attachments for optimal control of hydraulic attachments

## 4 WORK MODES AND 4 POWER MODES + BOOM / SWING PRIORITY CONTROL

Delivers the needed power according to your specific application while minimizing fuel consumption:

- 1-way mode, 2-way mode, digging mode and lifting mode
- Power plus mode, power mode, standard mode, economy mode
- Boom / swing priority control allows you to control operating modes with just 1 button – resulting in more comfortable and productive operation optimized for various work environments

## BOOM PRIORITY MODE

Hydraulic Power

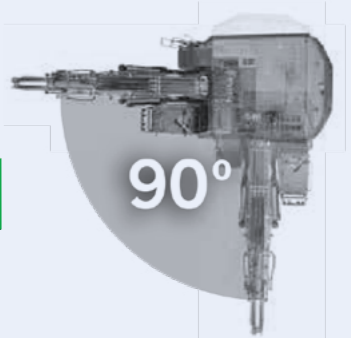

## SWING PRIORITY MODE

Hydraulic Power

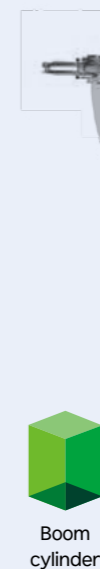

# HX1000A<sub>L</sub> SIMPLE MAINTENANCE



#### AIR COMPRESSOR

Air gun in your cab helps you keep the environment clean and comfortable.



#### WIDE CATWALK

Maintenance is made easier with 520 mm catwalk.

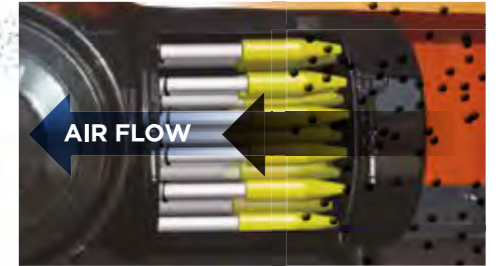

#### HEAVY-DUTY AIR CLEANER

2-stage air cleaner protects engine from dust and contaminating particles – avoids downtime and is easy to maintain.

#### REVERSIBLE FAN

- Rotating cooling fan in reverse direction is possible.
- Able to blow away dust on radiator and oil cooler easily to save time & effort.

#### CENTRALIZED FUEL FILTRATION SYSTEM

Water separator, pre-fuel filter and main filter are grouped together to increase engine life and prevent machine failures, making machine inspection or maintenance much easier with one simple access.

#### ELECTRIC FUEL TRANSFER PUMP (ETP)

Use this switch to easily refill fuel for your machine after its inspection or repair.

#### AUTO GREASE SYSTEM (AGS)

This new auto grease filling device helps reduce maintenance time significantly and prevents unexpected downtime.

# HX1000AL SPECIFICATIONS

Engine	
Make	Perkins
Model	2806J
Number of cylinders	6
Rated power, gross (hp per SAE J1995)	629 hp (469 kW) @ 2,000 rpm
Max. torque, gross (SAE J1995)	2,951 Nm (2,177 lbf*ft) @ 1,300 rpm
Displacement	18.1L (1,105 in <sup>3</sup> )
Bore and stroke	145 mm x 183 mm (5.7 in. x 7.2 in.)
Starter	9.0 kW (24 V, 12 hp)
Battery	2 x 12 V, 200 AH
Alternator	24 V, 115 A
Air cleaner	Double elements & precleaner

Hydraulics	
Main pumps	3 x 523 L/min. (3 x 138 gpm)
Pilot pump(Gear pump)	60 L/min. (15.9 gpm)

Working Pressure	
Boom/arm/bucket (normal mode)	367 kg/cm <sup>2</sup> (5,220 psi)
Travel	375 kg/cm <sup>2</sup> (5,334 psi)
Swing	300 kg/cm <sup>2</sup> (4,267 psi)

Undercarriage	
Upper rollers (each track)	3
Lower rollers (each track)	9
Number of shoes (links per side)	51

Swing Mechanism	
Swing speed	0 - 6.1 rpm
Swing torque	31,850 kgf*m (230,276 lbf*ft)

Drive System	
Travel speed [low – high]	2.6 – 4.3 km/h (1.6 – 2.7 mph)
Traction force, max. (drawbar pull)	60.6 ton (133,600 lb)
Max. gradability (limited by engine lubrication)	35° (70%)

Environment	
Sound level (2000/14/EC)	109 dB(A)
Cabin sound level (ISO 6396)	71 dB(A)

Refill Capacities	
Fuel tank	1,100 L (290.6 gal)
DEF tank	47 L (12.4 gal.)
Cooling system (radiator capacity)	105.1 L (27.5 gal.)
Engine oil (with filler)	65 L (17.2 gal.)
Swing drive (each)	2 x 8 L (2 x 2.1 gal.)
Final drive (each side)	25 L (6.6 gal)
Hydraulic system	880 L (232 gal)
Hydraulic tank	533 L (141 gal.)

Hydraulic Cylinders	
Boom (2) bore x rod diameter x stroke	215 mm x 150 mm x 1,905mm (with 8.40m boom) (8.5 in x 5.9 in x 75.0 in)
	215 mm x 150 mm x 1,910mm (with 7.25m boom) (8.5 in x 5.9 in x 75.2 in)
Arm (1) bore x rod diameter x stroke	240 mm x 170 mm x 2,020 mm (9.4 in x 6.7 in x 79.5 in)
Bucket (1) bore x rod diameter x stroke	210 mm x 145 mm x 1,530mm (with 8.40m boom) (8.3 in x 5.7 in x 60.2 in)
	225 mm x 160 mm x 1,530mm (with 7.25m boom) (8.3 in x 6.3 in x 60.2 in)

The piston rods and cylinder bodies are made of high-strength steel. A shock-absorbing mechanism is fitted in all cylinders to ensure shock-free operation and extended piston life.

NOTE: Where applicable, dimensions are in accordance with Society of Automotive Engineers (SAE) and ISO standards. Specifications and design are subject to change without notice. All dimensions are given for HYUNDAI excavators equipped with standard tracks and the standard front as listed. Pictures of HYUNDAI excavators may show other than standard equipment. All dimensions are shown in inches. Respective metric dimensions are enclosed by parentheses. HYUNDAI equipment is manufactured with a Quality Management System that is in compliance with ISO 9001:2008.

# HX1000AL DIMENSIONS

DIMENSIONS			
Boom length		8,400 mm (27' 7")	7,250 mm (23' 9")
Arm length		3,750 mm (12' 4")	2,900 mm (9' 6")
Bucket type (SAE)		5.4 m <sup>3</sup> (7.06 yd <sup>3</sup> )	6.8 m <sup>3</sup> (8.89 yd <sup>3</sup> )
Tail swing radius	A <sub>1</sub>	4,620 mm (15' 2")	
Tail swing overhang (rear)	A <sub>2</sub>	1,395 mm (4' 7")	
Tail swing overhang (side)	A <sub>3</sub>	2,465 mm (8' 2")	
Shipping height (boom)	B	5,450 mm (17' 11")	5,090 mm (16' 8")
Shipping height (hose)	C	5,550 mm (18' 3")	5,150 mm (16' 11")
Shipping length	D	14,550 mm (47' 9")	13,800 mm (45' 3")
Shipping width (without step)	E	3,440 mm (11' 4")	
Counterweight clearance*	F	1,560 mm (5' 1")	
Cabin height	G	3,615 mm (11' 10")	
Upper structure width	without catwalks	3,410 mm (11' 2")	
	with catwalks	4,450 mm (14' 7")	
Cabin height above house	I	-	
Cabin width	J	1,010 mm (3' 4")	
Tumbler distance	K	5,100 mm (16' 9")	
Overall track length	L	6,341 mm (20' 10")	
Undercarriage width (without step)	retracted	3,440 mm (11' 4")	
	extended	4,200 mm (13' 10")	
Undercarriage width (with step)	retracted	3,732 mm (12' 3")	
	extended	4,492 mm (14' 9")	
Track gauge (extended)	N	3,550 mm (11' 8")	
Track shoe width	O	650 mm (26")	
Track height	P	1,350 mm (4' 6")	
Ground body clearance*	Q	860 mm (2' 10")	

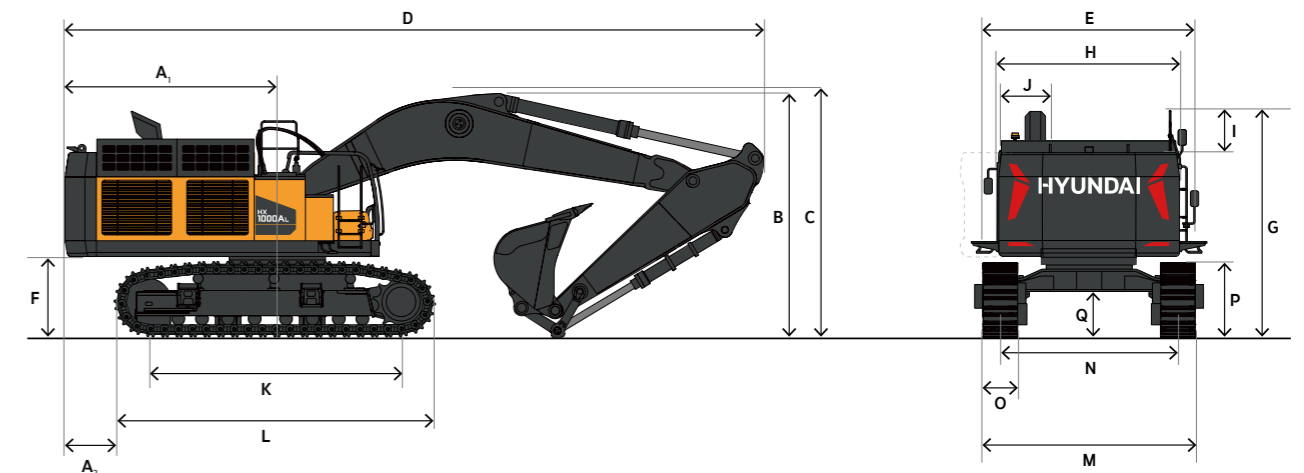

# HX1000AL WORKING RANGE

WORKING RANGE			
Boom length		8,400 mm (27' 7")	7,250 mm (23' 9")
Arm length		3,750 mm (12' 4")	2,900 mm (9' 6")
Bucket type (SAE, PCSA)		5.4 m <sup>3</sup> (7.06 yd <sup>3</sup> )	6.8 m <sup>3</sup> (8.89 yd <sup>3</sup> )
Max. digging reach	A	14,275 mm (46' 10")	12,430 mm (40' 9")
Max. digging reach (ground)	B	14,000 mm (45' 11")	12,110 mm (39' 9")
Max. digging depth	C	8,795 mm (28' 10")	7,260 mm (23' 10")
Max. loading height	D	9,440 mm (31' 0")	8,100 mm (26' 7")
Min. loading height	E	4,210 mm (13' 10")	3,910 mm (12' 10")
Max. digging height	F	13,840 mm (45' 5")	12,425 mm (40' 9")
Max. bucket pin height	G	11,862 mm (38' 11")	10,515 mm (34' 6")
Max. vertical wall depth	H	4,470 mm (14' 8")	2,965 mm (9' 9")
Max. radius vertical	I	12,265 mm (40' 3")	10,995 mm (36' 1")
Max. depth to 8' line	J	8,665 mm (28' 5")	7,110 mm (23' 4")
Min. radius to 8' line	K	5,290 mm (17' 4")	4,410 mm (14' 6")
Min. digging reach	L	3,365 mm (11' 0")	1,970 mm (6' 6")
Min. swing radius	M	6,295 mm (20' 8")	5,345 mm (17' 6")
Bucket angle (DEG)	d	143.8°	145.3°
Digging force, bucket (PCSA)	ISO	42,960 kgf (94,711 lbf)	48,200 kgf (106,263 lbf)
Digging force, arm		36,730 kgf (80,976 lbf)	40,800 kgf (89,949 lbf)
Operating weight		98,200 kg (216,494 lb)	97,900 kgf (215,833 lbf)
Ground pressure		1.37 kg/cm <sup>2</sup> (19.5 psi)	

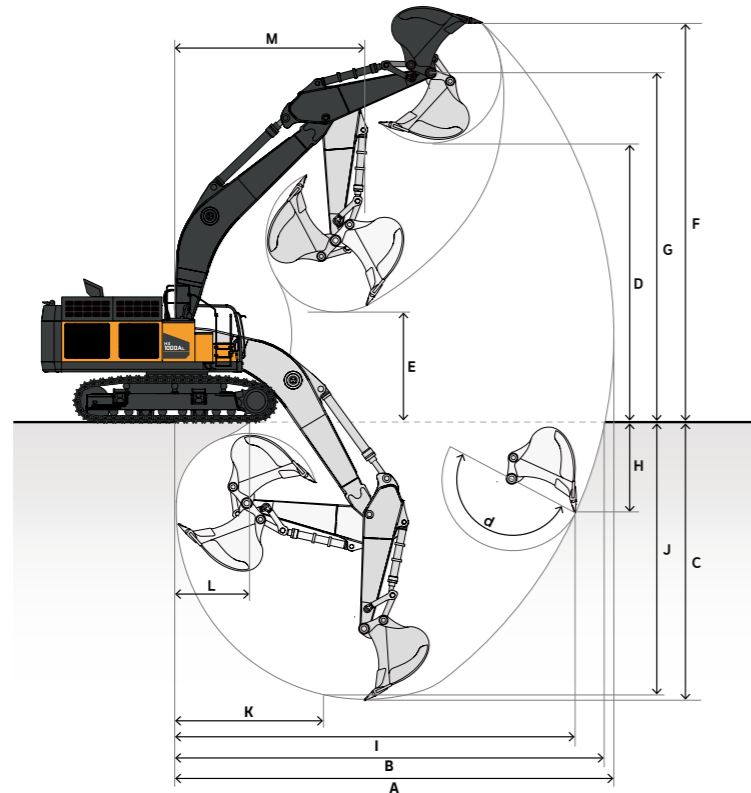

# HX1000AL BUCKET

TYPE	Capacity, m <sup>3</sup> (yd <sup>3</sup> ) - SAE	Width, mm(in)	Weight, kg(lb)	8,400mm Boom	7,250mm Boom
				3,750mm Arm	2,900mm Arm
S CLASS	5.4 (7.06)	1,940 (76)	5,214 (11,495)	D	A
	6.8 (8.89)	2,320 (91)	5,732 (12,637)	-	C

• S Class (Severe Duty): Designed for mass excavation in high-density, harsh mining and quarry environments. Built with high-strength, abrasion-resistant materials.

\*Capacity based on ISO 10567 and SAE J296, arm length without quick change clamp

- Equipped with bolt-on wear shrouds
- Equipped with bolt-on teeth
- Equipped with bolt-on cutting edge
- These recommendations are given as a guide only and based on typical operating conditions.

Please consult with your HYUNDAI dealer to properly match buckets and attachments for the application.

### Maximum Suitable Material Density

- A : Suitable for materials with density of 2,100kg/m<sup>3</sup> (3,500lb/yd<sup>3</sup>) or less
- B : Suitable for materials with density of 1,800kg/m<sup>3</sup> (3,000lb/yd<sup>3</sup>) or less
- C : Suitable for materials with density of 1,500kg/m<sup>3</sup> (2,500lb/yd<sup>3</sup>) or less
- D : Suitable for materials with density of 1,200kg/m<sup>3</sup> (2,000lb/yd<sup>3</sup>) or less
- Not recommended

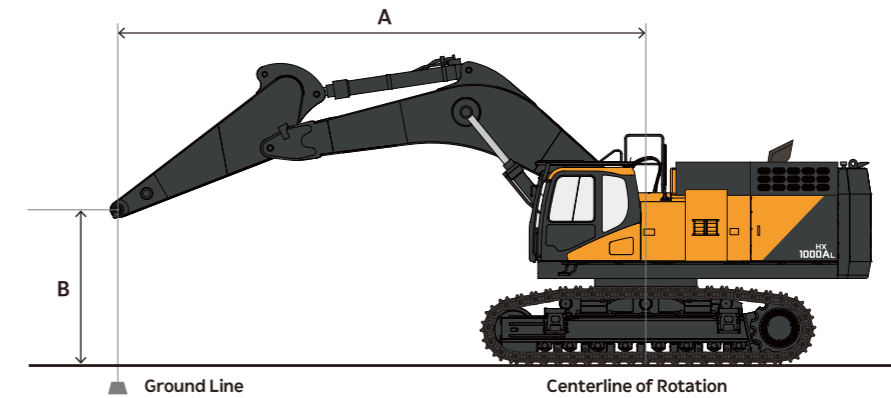

# HX1000AL LIFTING CAPACITY

Rating over-front Rating over-side or 360 degree

## HX1000AL

Boom: 8,400 mm (27' 7"), Arm: 3,750 mm (12' 4"), Counterweight: 11,300 kg (24,860 lb.), 900 mm (36") Double Grouser, No Dozer, Bucket: None, Unit: kg (lb.)

A (ft. or m)		15' (4.5 m)		20' (6.0 m)		25' (7.5 m)		30' (9.0 m)		35' (10.5 m)		Max. Reach		A
10.5 m	kg											* 14660	* 14660	9.05 m
35'	lb											(* 32320)	(* 32320)	(29.70')
9.0 m	kg											* 13920	* 13920	10.17 m
30'	lb											(* 30690)	(* 30690)	(33.36')
9.8ft	kg					* 18480	* 18480	* 16760	* 16760	* 15770	15360	* 13640	* 13640	10.97 m
25'	lb					(* 40750)	(* 40750)	(* 36950)	(* 36950)	(* 34770)	(33860)	(* 30070)	(* 30070)	(35.98')
8.2ft	kg					* 20440	* 20440	* 17820	* 17820	* 16200	15000	* 13680	12710	11.50 m
20'	lb					(* 45060)	(* 45060)	(* 39280)	(* 39280)	(* 35710)	(33070)	(* 30160)	(28030)	(37.75')
6.6ft	kg					* 22680	* 22680	* 19100	18520	* 16870	14510	* 14010	11850	11.83 m
15'	lb					(* 50010)	(* 50010)	(* 42110)	(40830)	(* 37200)	(31990)	(* 30880)	(26120)	(38.80')
4.9ft	kg					* 24720	23040	* 20340	17670	* 17570	14000	* 14640	11380	11.95 m
10'	lb					(* 54500)	(50790)	(* 44840)	(38970)	(* 38730)	(30870)	(* 32270)	(25090)	(39.21')
3.3ft	kg					* 26100	22010	* 21270	16990	* 18090	13570	* 15630	11270	11.88 m
5'	lb					(* 57540)	(48520)	(* 46890)	(37450)	(* 39880)	(29920)	(* 34450)	(24840)	(38.98')
Ground Level	kg					* 26600	21410	* 21680	16520	* 18230	13280	* 16090	11510	11.62 m
	lb					(* 58650)	(47190)	(* 47800)	(36430)	(* 40200)	(29270)	(* 35460)	(25380)	(38.11')
-1.5 m	kg					* 32780	29700	* 26180	21170	* 21410	16320	* 17760	12190	11.14 m
-5'	lb					(* 72260)	(65470)	(* 57710)	(46680)	(* 47200)	(35970)	(* 39150)	(29050)	(36.55')
-3.0 m	kg	* 37670	* 37670	* 30520	29960	* 24730	21260	* 20200	16380			* 16260	13500	10.42 m
-10'	lb	(* 83060)	(* 83060)	(* 67280)	(66050)	(* 54530)	(46870)	(* 44530)	(36110)			(* 35850)	(29760)	(34.19')
-4.5 m	kg	* 32730	* 32730	* 26910	* 26910	* 21930	21680	* 17380	16800			* 15960	15890	9.41 m
-15'	lb	(* 72150)	(* 72150)	(* 59330)	(* 59330)	(* 48350)	(47780)	(* 38320)	(37040)			(* 35180)	(35030)	(30.88')
-6.0 m	kg			* 21140	* 21140	* 16600	* 16600					* 14760	* 14760	7.98 m
-20'	lb			(* 46610)	(* 46610)	(* 36590)	(* 36590)					(* 32550)	(* 32550)	(26.19')

A Distance from center of rotation  
B Height

NOTE: Lifting capacities are in compliance with SAE 1097 and ISO 10567. Machine in lifting mode with power boost turned on. Load point is the end of the arm. Rated loads shown do not exceed 75% of minimum tipping loads or 87% of hydraulic capacities. Rated loads marked with an asterisk (\*) are limited by hydraulic capacities. The least stable position is over the side. The total mass of machine includes the mass of the boom, arm, counterweight, all operating fluids and 165 lb. (75 kg) operator.

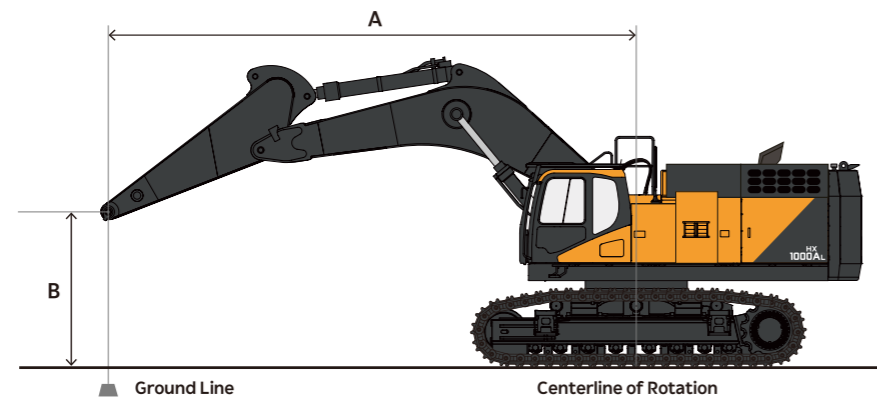

# HX1000AL LIFTING CAPACITY

Rating over-front Rating over-side or 360 degree

## HX1000AL

Boom: 7,250 mm (23' 9"), Arm: 2,900 mm (9' 6"), Counterweight: 11,300 kg (24,860 lb.), 900 mm (36") Double Grouser, No Dozer, Bucket: None, Unit: kg (lb.)

A (ft. or m)		4.5 m (15')		6.0 m (20')		7.5 m (25')		9.0 m (30')		Max. Reach		A		
10.5 m	kg											* 43780	* 43780	20.99'
35'	lb											(* 19860)	(* 19860)	(6.40 m)
9.0 m	kg							* 46570	* 46570			* 39360	* 39360	25.93'
30'	lb							(* 21120)	(* 21120)			(* 17850)	(* 17850)	(7.90 m)
9.8ft	kg							* 47040	* 47040			* 37570	* 37570	29.23'
25'	lb							(* 21340)	(* 21340)			(* 17040)	(* 17040)	(8.91 m)
8.2ft	kg							* 26700	* 26700	* 50180	* 50180	* 45440	* 45440	31.39'
20'	lb							(* 58870)	(* 58870)	(* 22760)	(* 22760)	(* 20610)	(* 20610)	(9.57 m)
6.6ft	kg							* 30640	* 30640	* 54530	* 54530	* 47320	44400	32.67'
15'	lb							(* 67560)	(* 67560)	(* 24730)	(* 24730)	(* 21460)	-20140	(9.96 m)
4.9ft	kg							* 34080	* 34080	* 58720	56260	* 49410	43040	33.15'
10'	lb							(* 75130)	(* 75130)	(* 26640)	-25520	(* 22410)	-19520	(10.10 m)
3.3ft	kg							* 79020	75140	* 61510	54350	* 50790	41910	32.88'
5'	lb							(* 35840)	-34080	(* 27900)	-24650	(* 23040)	-19010	(10.02 m)
Ground Level	kg							* 78850	73900	* 62030	53250	* 50560	41260	31.84'
	lb							(* 35770)	-33520	(* 28140)	-24160	(* 22930)	-18720	(9.70 m)
-1.5 m	kg	* 43150	* 43150	* 75010	73820	* 59610	53010	* 47190	41350	* 46020	40640	* 45320	* 45320	29.94'
-5'	lb	(* 95130)	(* 95130)	(* 34030)	-33480	(* 27040)	-24050	(* 21400)	-18750	(* 20870)	-18430	(* 20560)	(* 20560)	(9.13 m)
-3.0 m	kg	* 37880	* 37880	* 66940	* 66940	* 52700	* 52700							27.00'
-10'	lb	(* 83510)	(* 83510)	(* 30360)	(* 30360)	(* 23900)	(* 23900)							(8.23 m)
-4.5 m	kg	* 29390	* 29390	* 51600	* 51600							* 41910	* 41910	22.61'
-15'	lb	(* 64800)	(* 64800)	(* 23410)	(* 23410)							(* 19010)	(* 19010)	(6.89 m)

A Distance from center of rotation  
B Height

NOTE: Lifting capacities are in compliance with SAE 1097 and ISO 10567. Machine in lifting mode with power boost turned on. Load point is the end of the arm. Rated loads shown do not exceed 75% of minimum tipping loads or 87% of hydraulic capacities. Rated loads marked with an asterisk (\*) are limited by hydraulic capacities. The least stable position is over the side. The total mass of machine includes the mass of the boom, arm, counterweight, all operating fluids and 165 lb. (75 kg) operator.

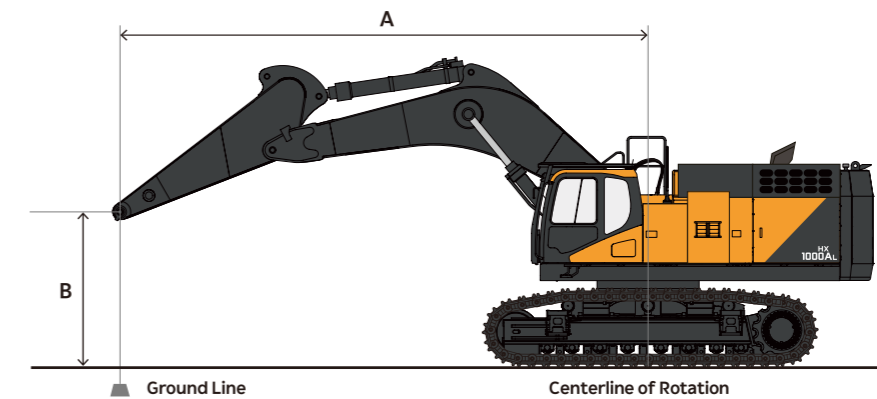

# HX1000AL TRANSPORTATION

## UPPER STRUCTURE (WITHOUT COUNTERWEIGHT)

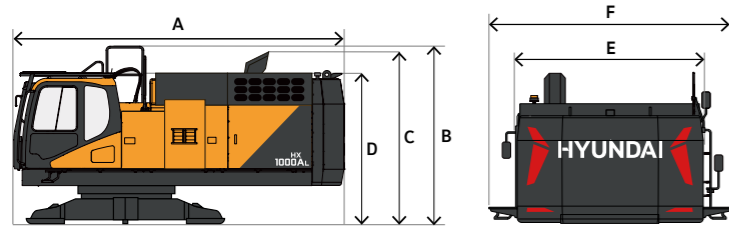

Length	A	6,282 mm
Height (top of guardrail)	B	3,280 mm
Height (top of muffler)	C	3,215 mm
Height (top of cab)	D	2,720 mm
Width (without walkways)	E	3,410 mm
Width (with walkways)	F	4,450 mm
Weight		32,870 kg

## UNDERCARRIAGE

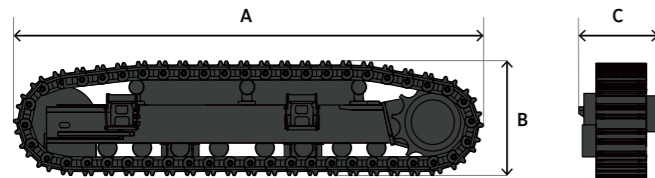

Length	A	6,341 mm
Height	B	1,452 mm
Width (with steps)	C	1,186 mm
Weight		14,150 kg

## COUNTERWEIGHT

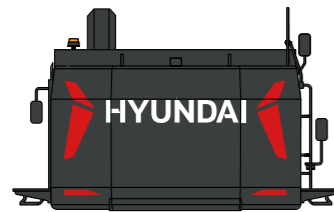

	STD	Removal Opt.
Length	4,450 mm	4,450 mm
Height	716 mm	675 mm
Width	2,119 mm	1,968 mm
Weight	12,700 kg	11,300 kg

## BOOM

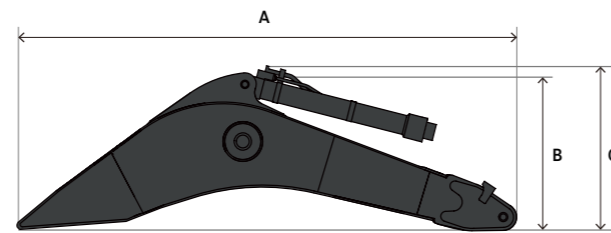

		8.4 m	7.25 m
Length	A	8,805 mm	7,640 mm
Height (top of boom)	B	2,220 mm	2,465 mm
Height (top of hoses)	C	2,340 mm	2,610 mm
Width		1,340 mm	1,340 mm
Weight		10,740 kg	10,230 kg

## ARM

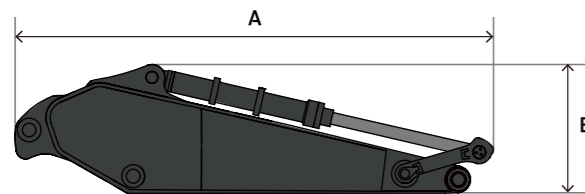

		3.75 m	2.9 m
Length	A	5,305 mm	4,490 mm
Height	B	1,730 mm	1,500 mm
Width		820 mm	820 mm
Weight		5,825 kg	5,590 kg

## BUCKET

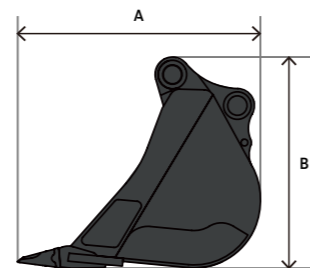

		5.4 m³	6.8 m³
Length	A	2,750 mm	2,750 mm
Height	B	2,350 mm	2,350 mm
Width		1,940 mm	2,320 mm
Weight		5,214 kg	5,732 kg

# HX1000AL STANDARD & OPTIONAL EQUIPMENT

● : Standard / ○ : Option

## ENGINE

Stage V compliant	●
Turbo, waste gate (WGT)	●
Air-to-air intercooler	●
Selective catalyst reduction (SCR)	●
Diesel oxidation catalyst (DOC)	●
Diesel particulate filter (DPF)	●
Three-stage air cleaner (cyclonic pre-filter & 2 filter elements)	●

## HYDRAULIC

Pilot-operated control valves	●
Pattern control change valve	○
Removable counterweight system	○
Variable-speed hydraulic cooling fan	●
Axial piston swing motors	●
Auxiliary hydraulics, one- & two-way piping with pedal	○
Auxiliary hydraulics, rotate piping	○
Quick coupler piping	○
Adjustable auxiliary flow & pressure, 5 presets	○
Intelligent floating boom	●
Breaker return filter	○
Boom & arm lock valves	●
Boom & arm flow regeneration	●
Straight travel	○

## CONTROLS

Proportional control for auxiliary hydraulics, roll switch on both joysticks	○
Auto idle control system, one-touch deceleration button on joystick	●
Engine speed control dial	●
Advanced mechatronics with power mode control system	●
Power modes (P+, P, S, E)	●
Work modes (excavating, lifting, breaker, shear)	●
Jog dial display control	●
Electronic Power Optimizing System (EPOS)	●
Cross-sensing pump control	●

## CABIN

Steel, all-weather & sound-suppressed	●
Vandalism guard hooks	○
Cabsus mount	●
Front window with wiper/washer	●
Tinted safety glass	●
Skylight top hatch with sun screen	●
Pull-up type top front window	●
Removable lower front window with storage behind seat	●
Adjustable sliding side door window	●
Defrost, front window	●
Seat - Heated - Air suspension - 2" (51 mm) seat belt - Adjustable height & recline - Adjustable fore/aft - Adjustable armrests - Adjustable lumbar	●
Heating & Cooling seat	○
Fully automatic HVAC with ambient temperature sensor	●
8" multi-function LCD interactive display monitor	●
Digital Bluetooth® audio broadcasting MP3 radio with cell phone integration - Audio control panel on/off switch - Control volume - Channel select	●
Antenna, roof-mounted	●
Cup holder	●
Shoe case	●
Coat hanger	●
Rain shield	○
Fog guard	○
Front window guard	○

## ELECTRICAL

System voltage – 24 V	●
Alternator – 24 V, 115 amp	●
2 x 12 V batteries, 200 AH reserve capacity	●
Main circuit breaker	●
Power sockets – 12 V	○
Electrical remote box with spare fuses & spare relays	●
LED lights: machine (3), boom (2), cabin(2)	●
Cabin light (LED) : 6	○
Rotating beacon	●
Overload warning alarm	○
Hour meter	●
Engine restart prevention system	●
Side view & rear view camera	○
360° all-around view camera	○
Laptop service port	●
Self-diagnostics system	●
Smart key	●
Emergency stop switch	●
Swing alarm	○
Travel alarm	○
Lower window wiper	○
HYUNDAI Fleet Management	○

## UNDERCARRIAGE

Track guards & chains with adjusters	●
Track rollers, upper	●
Track rollers, lower	●
Shoes, double grouser – 650 mm	●
Shoes, double grouser – 750 mm	○
Shoes, double grouser – 900 mm	○

## OTHER

Automatic lubrication	○
Handrails & service platforms	●
Skid-resistant steps & service platforms, upper deck	●
HYUNDAI Fleet Management 3-year subscription	○
Air compressor	○

\* Standard and optional equipment may vary. Contact your Hyundai dealer for more information. The machine may vary according to International standards.

\* The photos may include attachments and optional equipment that are not available in your area.

\* Materials and specifications are subject to change without advance notice.

\* All imperial measurements rounded off to the nearest pound or inch.