

HL930A

With EU Stage V Engine installed

* Photo may include optional equipment.



Head Office(Sales Office)
14F, GLOBAL R&D CENTER, 477 BUNDANG SUSEO-RO, BUNDANG-GU, SEONGNAM-SI, GYEONGGI-DO, 13553, KOREA

PLEASE CONTACT

Gross Power
133 HP (99 kW) at 2,200 rpm

Net Power
130 HP (97 kW) at 2,200 rpm

Bucket Capacity
1.8 ~ 1.9 m³

Operating Weight
11,500kg / 25,355 lb

WHAT'S NEWEST AND BEST

HL930A

THE BEST PRODUCTIVITY AND FUEL EFFICIENCY

- EU STAGE V Engine **NEW**
- Eco Report **NEW**
- Smart Power Mode **NEW**
- Hydraulic Differential Lock **Option**
- ICCO (Intelligent Clutch Cut Off)
- Automatic Engine Shut Down
- Optimized Power Matching

ULTIMATE DURABILITY

- Enhanced Axle Capacity
- Sinter Brake Disc
- Hydraulic Hose
- Optimized Drive Shaft

EASY CONTROL AND COMFORTABLE OPERATION

- Foldable Side Mirror **NEW**
- Fully Adjustable Seat and Armrest **NEW**
- Air Compressor **NEW** **Option**
- Remote Door Control **NEW** **Option**
- Auto Greasing System **Option**
- Ride Control **Option**
- Full Sound-Proofed Spacious Cabin
- Wide Touch Screen Monitor
- Centralized Cluster
- Soft end Stop
- Weighing System

THE ULTIMATE SAFE ENVIRONMENT

- Emergency Stop **NEW**
- Seat Belt Warning Alarm **NEW**
- Radar **NEW** **Option**
- AVM (Around View Monitoring) **Option**
- IMOD (Intelligent Moving Object Detection) **Option**

SERVICEABILITY AND TELEMATICS

- Unnecessary Regular DPF Cleaning Interval **NEW**
- ECD(Engine Connected Diagnostics) **NEW**
- Hi MATE **Option**
- Easy Filter Replacement
- Wide Core & Fin Radiator
- Longer Lasting Filter



*Photo may include optional equipment.



THE BEST PRODUCTIVITY AND FUEL EFFICIENCY

The new HYUNDAI HL930A with new engine technologies is satisfying the most strict environmental emission regulation in the world and A series in wheel loader have a number of new features that contribute to overall fuel and also production efficiency.



Photo may include optional equipment.

FUEL SAVINGS
up to **5%**
V-type loading cycle
(Compared to Power mode)

Smart Power Mode **NEW**

Smart Power mode reduces fuel consumption by adjusting the engine speed in heavy load work like digging. The key point of this function is not only saving fuel with same performance as Power mode but also making good balance between traction force and breakout force.



Hydraulic Differential Lock **Option**

Hydraulic differential lock has the advantages of both improving productivity and less fuel consumption by preventing tire slip during the operation.

Engagement-Manual / Auto
(100% Traction with tire slip)

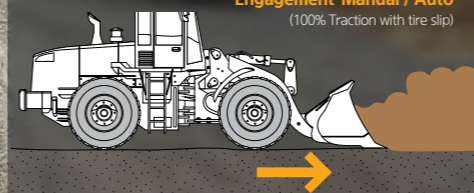

ICCO (Intelligent Clutch Cut Off)

By selecting of 'H-Mode' among clutch cut-off selections, ICCO will be engaged for both less power loss in torque converter and lower heat generation on brake sides.

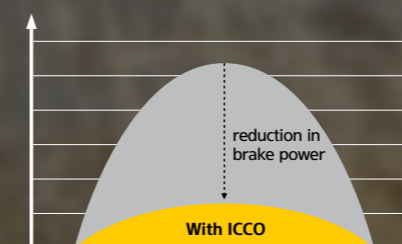

EU STAGE V Engine **NEW**

'Cummins B4.5' engine meeting Euro Stage V emission regulations is designed for maximum productivity and fuel efficiency.

Tier4 Final(2014)
EU Stage-V(2019)

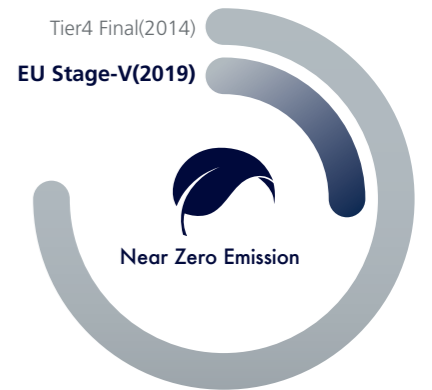

Eco Report **NEW**

Eco report shows the wheel loader's inefficient operation status in order to improve operator's improper working habit.

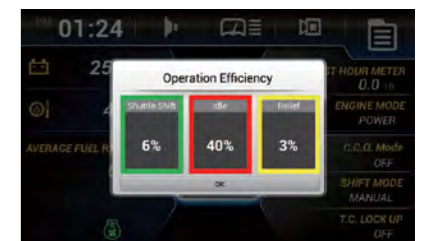

Automatic Engine Shut Down

Adjustable 'Automatic engine shut down' significantly reduces idle time, overall operating hours and fuel consumption.

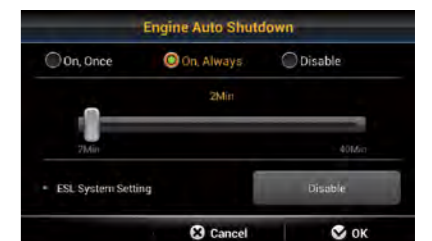

Optimized Power Matching

For maximum operational efficiency, the engine is designed to achieve high torque in the low RPM range. Change an engine rpm at peak torque to lower rpm section also.



ULTIMATE DURABILITY

The true value of the HL930A, which is now far more powerful, is revealed in tough working environments. With the high-strength design structure and enduring system proven by rigorous road tests at various work sites, Hyundai wheel loaders can perform any high-load work to maximize productivity.

Enhanced Axle Capacity

HL930A applied larger capacity axle than the previous series. It offers more reliable performance and longer durability.



Sinter Brake Disc

The HL930A has a sinter disc of a new material with excellent durability to suppress generation of heat and vibration, heightening brake durability and enabling convenient maintenance with a service-friendly design.

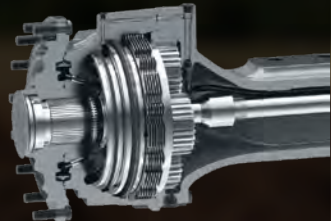

Hydraulic Hose

Hyundai's hydraulic hoses have twice increased durability and product life cycle over previous hoses.



Optimized Drive Shaft

Through thorough verification, the optimized drive shaft makes the HL930A wheel loader more durable.



Air Compressor **NEW** **Option**

Air Compressor will be used for cleaning inside the cabin and for operator self-cleaning.



Full Sound-Proofed Spacious Cabin

State-of-the-art noise reduction technology of the HL930A ensures maximum silence(70 dB) in the same category of equipment, promising more silent and more pleasant interior space.



Remote Door Control **NEW** **Option**

Remote door control allows operators to open the cabin door remotely. This system was developed for the convenience and safety of the operator.



Wide Touch Screen Monitor

The seven-inch capacitive-type display (like a smart phone display) provides excellent legibility.



Centralized Cluster

With a centralized cluster, operator can see at a glance all the states of wheel loader.



Weighing System

The HL930A further improves work precision with additional weight calibration. The automatic/manual cumulative weighing function greatly enhances operating efficiency. Icons displaying weighing errors and the two-color weight value indication on the monitor enable accurate weighing to support efficient production management.

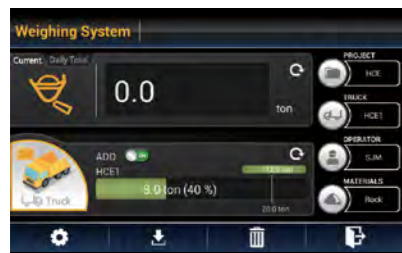

Soft End Stop

When an attachment reaches at the end stroke, it gives operator enormous shock especially for Boom up. This function gives shock free operation by reducing the speed of attachment near the end stroke. It can be selected on/off through Monitor.

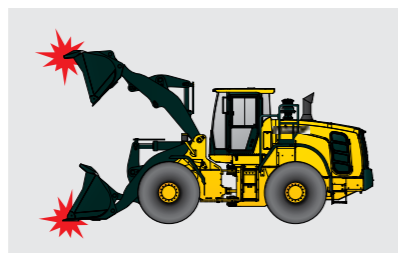

Foldable Side Mirror **NEW**

Foldable side mirrors prevent damage when transporting narrow space.



Fully Adjustable Seat and Armrest **NEW**

This suspension will be applied for minimizing an operator's fatigue. Available for electro hydraulic control.



Ride Control **Option**

Ride control system reduces operator fatigue and material spillage during operation. An accumulator helps to minimize shock, giving the operator a much smoother ride.



Auto Greasing System **Option**

Auto greasing system is designed to automatically lubricate when it is needed. Uniform application of lubricant ensures that the lubrication points always have the correct amount of grease.



EASY CONTROL AND COMFORTABLE OPERATION

The HL930A is optimized to enable operators to access accurate equipment data in a timely manner. This feature is more important in tough working environments to increase productivity while enjoying various forms of entertainment. Enjoy unparalleled satisfaction provided by infotainment of Hyundai's state-of-the-art information technology!



*Photo may include optional equipment.

// HL930A with advanced technology ensures our safety on a construction site. //



The A Series in wheel loaders are products of HCE's spirit of initiative, creativity, and strong drive. HCE engineers, who are the best in the industry, have worked tirelessly to offer a zero-defect product. The new A Series in wheel loaders reflects customers' needs in the field gleaned by thorough monitoring.

Emergency Stop **NEW**

In an emergency, operating the Emergency Stop switch located at the bottom of the seat will shut down the engine starting.



Seat Belt Warning Alarm **NEW**

Seat belt warning alarm allows the operator to work in a safer environment.



Radar **NEW** Option

The Radar system can detect rear obstacles without blind spots and no distinction between day and night. Also, the warning level of the nearest obstacle is always displayed on the secondary monitor.

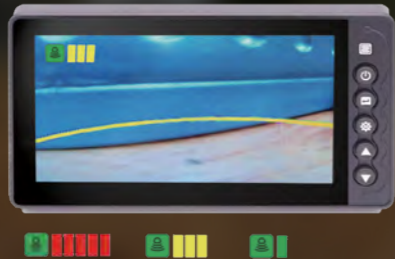

AVM(Around View Monitoring) **Option**

IMOD(Intelligent Moving Object Detection) **Option**

This is a system that is combined AVM (Around View Monitoring) with IMOD (Intelligent Moving Object Detection) and detects people around the machine and analyzes the images, which displays a warning sign on a monitor when detecting the danger. So operators can watch the surroundings in a variety of angles through the monitor and prevent the safety accident in advance.

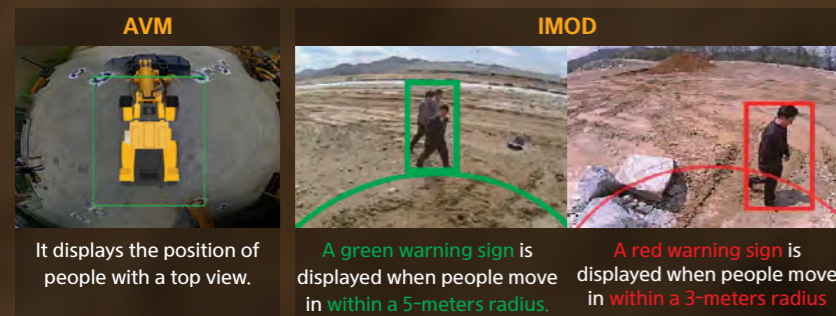

It displays the position of people with a top view.

A green warning sign is displayed when people move in within a 5-meters radius.

A red warning sign is displayed when people move in within a 3-meters radius.



THE ULTIMATE SAFE ENVIRONMENT

With the top priority on satisfaction of operators in terms of silence, safety and maintainability, Hyundai wheel loaders provide operators with comfortable cabin space by low-vibration, low-noise, and superior safety design. They also offer greater satisfaction by extending the replacement cycle of supplies and minimizing maintenance time and cost.





SERVICEABILITY AND TELEMATICS

IoT, ICT, AI-based digital technologies is creating smart construction sites. Maximizes connectivity, productivity, and safety for your successful businesses.



Hi MATE

Option

IT'S CONVENIENT, EASY AND VALUABLE

Hi MATE Hyundai's newly developed remote management system, utilizes GPS-satellite technology to provide customers with the highest level of service and product support available. Hi MATE enables users to remotely evaluate machine performance, access diagnostic information, and verify machine locations at the touch of a button.

WHAT IS BENEFITS



Increase Productivity

It helps you operate machines in efficient. You can check the difference between total engine hours and actual working hours. See how productive your machines are and plan any required cost saving solutions. Hi MATE offers working information such as working / idling hours, fuel consumption and rate.



Convenient and Easy Monitoring

There is nothing much to do to monitor your machines. Just log on to the Hi MATE website or mobile application. Hi MATE allows you to watch your machines whenever and wherever you are.



Security

Protect your machines from theft or unauthorized usage with Hi MATE. If the machine moves out of the Geo-fence boundary, you will get alerts.

*Photo may include optional equipment.

Unnecessary Regular DPF Cleaning Interval **NEW**

Regular ash cleaning for DPF is not necessary, only needed as indicated by fault-indicator lamp.

ECD(Engine Connected Diagnostics) **NEW**

It supports service technician with remote diagnostics report and ensure it arrive on site with proper tools after preparing in advance.

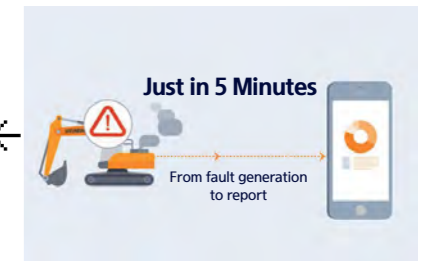
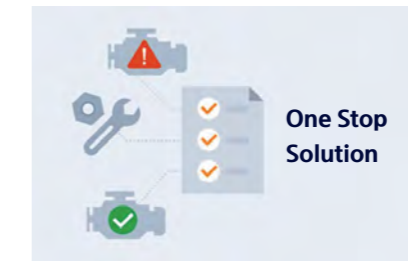

Easy Filter Replacement

With easy filter replacement, machine can be managed more easily.



Wide Core & Fin Radiator

Wide core & fin radiator reduces clogging.

Longer Lasting Filter

The service interval of fuel filters has been increased from 500 hours to 1,000 hours.



200%
IMPROVED

SPECIFICATIONS

ENGINE	
Maker / Model	CUMMINS / B4.5
Type	4 cylinder, water cooled, 4-cycle, turbocharged, charge air cooled, direct injection, electronic controlled diesel engine
Gross Power	99 kW (133 hp) at 2,200 rpm
Net Power	97 kW (130 hp) at 2,200 rpm
Max. Power	99 kW (133 hp) at 2,200 rpm
Peak Gross Torque	633 N · m (467 lb · ft) at 1,200 rpm
Displacement	4.5 l (275 cu in)

TRANSMISSION		
Torque Converter Type	3-Elements, Single-stage, Single phase	
Tire	17.5 R25, ★★, L3	
Travel Speed, km/h (mph)	4 speed T/M	
Forward	1st	6.6 (4.1)
	2nd	12.1 (7.5)
	3rd	23.6 (14.7)
	4th	39.5 (24.5)
Reverse	1st	7.0 (4.3)
	2nd	12.7 (7.9)
	3rd	24.8 (15.4)

AXLES	
Drive System	Four-wheel drive system
Mount	Rigid front axle and oscillating rear axle
Rear Axle Oscillation	Oscillating ±11° degrees
Hub Reduction	Planetary reduction at wheel end
Differential	Conventional
Reduction Ratio	20.365

HYDRAULIC SYSTEM		
Type	Load sensing hydraulic system	
Pump	Variable displacement piston pump, 132 lpm	
Control valve	3 spool (Bucket, Boom, Aux)	
System pressure	250 bar (3,626 psi)	
Lift Circuit	The valve has four functions: raise, hold, lower and float can adjust automatic kickout from horizontal to full lift.	
Tilt Circuit	The valve has three functions: tilt back, hold and dump. Can adjust automatic bucket positioner to desired load angle.	
Cylinder	Type: Double acting	
	No. of cylinders-bore x stroke:	
	Lift	2 - 100 X 750 mm (3.9" X 2' 6")
	HL930A Tilt	110 X 510 mm (4.3" X 1' 8")
	HL930A XT Tilt	110 X 515 mm (4.3" X 1' 8")
	HL930A TM Tilt	2 - 90 X 775 mm (3.5" X 2' 7")
Cycle Time	Raise: 5.8 sec, Dump: 2.2 sec Lower: 3.6 sec, Total: 11.6 sec	

* Hyundai Bio Hydraulic Oil (HBHO) available

TIRES	
Type	Tubeless, loader design tires
Standard	17.5 R25, ★★, L3
Options include	17.5 R25, ★, XHA 17.5-25 12PR L3

OVERVIEW			
Description	HL930A	HL930A XT	HL930A TM
Operating weight	11,500kg (25,355 lb)	11,700kg (25,795 lb)	11,960kg (26,370 lb)
Bucket capacity	Heaped	1.9m³ (2.5yd³)	1.7m³ (2.2yd³)
	Struck	1.6m³ (2.1yd³)	1.4m³ (1.8yd³)
Breakout force-bucket		9,150kg (20,175 lb)	9,070kg (20,000 lb)
		9,100kg (20,065 lb)	8,200kg (18,080 lb)
Tipping load	Straight	8,000kg (17,640 lb)	7,050kg (15,545 lb)
	Full turn	8,000kg (17,640 lb)	7,050kg (15,545 lb)

BRAKES	
Service Brakes	Hydraulically actuated, wet disc brakes actuate all 4 wheels independent axle-by-axle system. Self adjusting & wheel speed brake.
Parking Brake	Spring-applied, hydraulically released brake
Emergency Brake	When brake oil pressure drops, indicator light alerts operator and parking brake automatically applies.

STEERING SYSTEM	
Type	Load sensing hydrostatic articulated steering
Pump	Variable displacement piston pump, 132 lpm
Relief Valve Setting	210 bar (3,046 psi)
Cylinder	Double acting 2-60 X 412 mm (2.4" X 1' 4")
Steering Angle	40° to both right and left angle, respectively
Features	Center-point frame articulation. Tilt and telescopic steering column.

SERVICE REFILL CAPACITIES	
Fuel tank	189.5 liters (50 US gal)
DEF tank	19.0 liters (5.0 US gal)
Cooling system	31.5 liters (8.3 US gal)
Crankcase	11.0 liters (2.9 US gal)
Transmission	34.5 liters (9.1 US gal)
Front axle	23.0 liters (6.1 US gal)
Rear axle	23.0 liters (6.1 US gal)
Hydraulic tank	90.0 liters (23.8 US gal)
Hydraulic system (including tank)	130.0 liters (34.3 US gal)

CABIN	
ROPS / FOPS Cabin Meet ISO 3471 and ISO 3449	

SOUND	
Guaranteed noise level presented below can be differed depending on a range of factors such as operating condition, speed of a cooling fan, types of engine and so forth. Hearing protection shall be necessary if an operator is working in the improperly maintained cabin or exposed to a noisy environment by leaving doors and/or windows open.	

With cooling fan speed at maximum value:	
Operator sound pressure level (ISO 6396:2008)	70 dB(A)
Exterior sound power level (ISO 6395:2008)	102 dB(A)

* Distance of 15 m (49.2 ft), moving forward in second gear ratio.

DIMENSIONS & SPECIFICATIONS

HL930A DIMENSIONS			
All dimensions are approximate.			

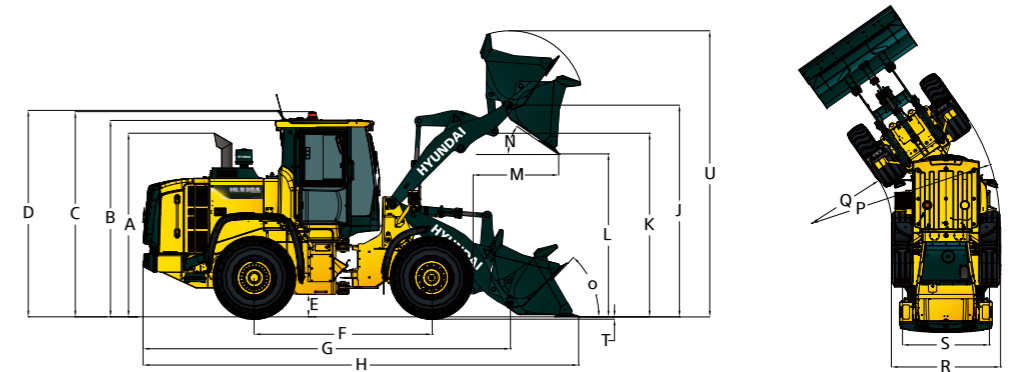

Model	HL930A	HL930A XT	HL930A TM
A Height to Top of Exhaust Pipe	2,945 (9' 8")	2,945 (9' 8")	2,945 (9' 8")
B Height to Top of Cabin	3,170 (10' 5")	3,170 (10' 5")	3,170 (10' 5")
C Height to Top of Product Link Antenna	3,235 (10' 7")	3,235 (10' 7")	3,235 (10' 7")
D Height to Top of Warning Beacon	3,300 (10' 10")	3,300 (10' 10")	3,300 (10' 10")
E Ground Clearance	370 (1' 3")	370 (1' 3")	370 (1' 3")
F Wheelbase	2,900 (9' 6")	2,900 (9' 6")	2,900 (9' 6")
G Overall Length (Without Bucket)	6,090 (19' 12")	6,380 (20' 11")	6,150 (20' 2")
H Shipping Length (With Bucket Level on Ground)	7,125 (23' 5")	7,415 (24' 4")	7,230 (23' 9")
I Hinge Pin Height at Carry Position	405 (1' 4")	495 (1' 7")	415 (1' 4")
J Hinge Pin Height at Maximum Lift	3,640 (11' 11")	3,980 (13' 1")	3,795 (12' 5")
K Lift Arm Clearance at Maximum Lift	3,125 (10' 3")	3,465 (11' 4")	3,035 (9' 11")
L Dump Clearance at Maximum Lift and 45° Discharge	2,700 (8' 10")	3,035 (9' 11")	2,785 (9' 2")
M Reach at Maximum Lift and 45° Discharge	1,065 (3' 6")	1,035 (3' 5")	1,160 (3' 10")
N Dump Angle at Maximum Lift and Dump (on Stops)	48	48	50
O Roll Back Angle	Ground	42	49
	Carry	47	48
P Clearance Circle (Diameter) to Outside of Tires	10,555 (34' 8")	10,555 (34' 8")	10,555 (34' 8")
Q Clearance Circle (Diameter) to Inside of Tires	5,710 (18' 9")	5,710 (18' 9")	5,710 (18' 9")
R Width Over Tires (Unloaded)	2,375 (7' 10")	2,375 (7' 10")	2,375 (7' 10")
S Tread Width	1,930 (6' 4")	1,930 (6' 4")	1,930 (6' 4")

OPERATING SPECIFICATIONS WITH BUCKETS							
Linkage	Bucket Type	General Purpose Pin On		General Purpose - Hook on	Original Type General Purpose - Hook on	Univarsal Type General Purpose - Hook on	High Lift Linkage Change
		Bolt-On Cutting Edges	1Piece tooth Cutting Edges	Bolt-On Cutting Edges	Bolt-On Cutting Edges	Bolt-On Cutting Edges	
Capacity - Rated	m³	1.90	1.80	1.90	1.7	1.9	-
		2.50	2.40	2.50	2.2	2.5	-
Capacity - Rated at 110% Fill Factor	yd³	2.10	2.00	2.10	1.9	2.1	-
		2.70	2.60	2.70	2.4	2.7	-
Width	mm	2,450	2,480	2,450	2,400	2,450	-
		ft/in	8' 0"	8' 2"	8' 0"	7' 10"	8' 0"
Dump Clearance at Maximum Lift and 45° Discharge	mm	2,700	2,620	2,550	2,785	2,615	335
		ft/in	8' 10"	8' 7"	8' 4"	9' 2"	8' 7"
Reach at Maximum Lift and 45° Discharge	mm	1,065	1,145	1,205	1,160	1,330	-30
		ft/in	3' 6"	3' 9"	3' 11"	3' 10"	4' 4"
Digging Depth	mm	105	115	105	95	95	15
		ft/in	0' 4"	0' 5"	0' 4"	0.4"	0.4"
T Shipping Length (with Bucket)	mm	7,125	7,240	7,330	7,230	7,470	290
		ft/in	23' 5"	23' 9"	24' 1"	23' 9"	24' 6"
U Overall Height with Bucket at Maximum Lift	mm	4,855	4,855	4,990	4,900	5,150	340
		ft/in	15' 11"	15' 11"	16' 4"	16' 1"	16' 11"
V Loader Clearance Circle	mm	11,660	11,750	11,780	11,640	11,810	280
		ft/in	38' 3"	38' 7"	38' 8"	38' 2"	38' 9"
Static Tipping Load, Straight (No Tire Deflection)	kg	9,100	9,270	8,400	8,100	7,600	-900
		lb	20,065	20,440	18,520	17,860	16,760
Static Tipping Load, Articulated (No Tire Deflection)	kg	8,000	8,150	7,380	7,050	6,600	-900
		lb	17,640	17,970	16,275	15,545	14,555
Breakout Force	kg	9,350	9,770	7,620	9,950	8,090	-80
		lb	20,615	21,540	16,800	21,940	17,840
Operating Weight*	kg	11,500	11,420	11,770	11,960	12,050	200
		lb	25,355	25,180	25,950	26,370	26,570

* All height and tire related dimensions are with standard 17.5 R25, ★★, L3 tires.

BUCKET SELECTION CHART

DENSITY OF OPERATING MATERIALS		
Loose Material	Material Density	
Earth/Clay	1.5 ~ 1.7	
Sand and Gravel	1.5 ~ 1.7	
Aggregate	25 ~ 76 mm (1" to 3 in)	1.6 ~ 1.7
	19 mm (3/4 in) and larger	1.8

HL930A BUCKET SELECTION CHART

Standard Lift Arm - General Purpose Bucket																
Type	m³	Material Density														
		1.0	1.1	1.2	1.3	1.4	1.5	1.6	1.7	1.8	1.9	2.0	2.1	2.2	2.3	2.4
Cutting edge	1.9	2.2 m³										1.8 m³				
1-Bolt on tooth	1.8	2.1 m³										1.7 m³				
Cutting Edge QC	1.9	2.2 m³					1.8 m³									

Type	m³	Material Density														
		1.0	1.1	1.2	1.3	1.4	1.5	1.6	1.7	1.8	1.9	2.0	2.1	2.2	2.3	2.4
Original Type Cutting edge Q/C	1.7	2.0 m³										1.6 m³				
Universal Type Cutting Edge QC	1.9	2.2 m³					1.8 m³									

High Lift Arm - General Purpose Bucket																
Type	m³	Material Density														
		1.0	1.1	1.2	1.3	1.4	1.5	1.6	1.7	1.8	1.9	2.0	2.1	2.2	2.3	2.4
Cutting edge	1.9	2.2 m³										1.8 m³				
1-Bolt on tooth	1.9	2.1 m³										1.7 m³				
Cutting Edge QC	1.9	2.2 m³					1.8 m³									

CHANGE IN OPERATING SPECIFICATIONS - TIRES

Tires		17.5 R25, ★, XHA	17.5-25 12PR L3
Operating Weight (kg)	kg	-30	-20
	lb	-65	-40
Static Tipping Load, Straight (No Tire Deflection)	kg	-40	-25
	lb	-85	-55
Static Tipping Load, Articulated (No Tire Deflection)	kg	-35	-20
	lb	-75	-40
Vertical Height Changes	mm	-4	6
	ft/in	0.2"	0.2"
R. Width Over Tires (Unloaded)	mm	3	5
	ft/in	0.1"	0.2"
P. Clearance Circle (Diameter) to Outside of Tires	mm	3	5
	ft/in	0.1"	0.2"
Q. Clearance Circle (Diameter) to Inside of Tires	mm	-3	-5
	ft/in	-0.1"	-0.2"

** Dimension changes compared to 17.5 R25, ★★, L3 radial tires.

STANDARD / OPTION

CAB & INTERIOR	STD
ALARMS, AUDIBLE AND VISUAL	
Air filter clogging	●
Battery voltage	●
Brake oil pressure	●
DEF low level	●
Engine coolant level	●
Engine oil pressure	●
Fuel level	●
Hydraulic oil temperature	●
Engine coolant temperature	●
Parking brake	●
Service brake oil pressure	●
Seat belt ON/OFF	●
Transmission error	●
Transmission oil temperature	●
GAUGES	
Diesel Exhaust Fluid (DEF) level	●
Engine coolant temperature	●
Fuel level	●
Speedometer	●
Transmission oil temperature	●
Horn, electric	●
INDICATOR LIGHTS	
Parking brake	●
High beam	●
FNR	
Differential Lock	
Pilot cut off	●
Turning light	●
Seat belt ON/OFF	●
Engine auto stop	●
Clutch Cut Off	●
Ride control	
LCD DISPLAY	
DEF level	●
DEF low level	●
Transmission gear range	●
Clock and fault code	●
Job time and distance	●
Operating hour counter	●
Engine rpm	●
Horn, electric	●
BATTERIES	
850CCA, 12V, 2PCS	●
LIGHTING SYSTEM	
Brake lights(Counterweight)	●
LED dome light	●
2 stop and tail lights	●
4 turn signals	●
2 Head lights on front tower	●
2 Head lights (LED) on front tower	
2 Working lights on front roof	●
4 Working lights on front roof	
2 Working lights on rear roof	
4 Working lights (LED) on front roof	
2 Working lights (LED) on rear roof	
2 Working lights on grill	●
2 Working lights (LED) on grill	

CAB & INTERIOR	STD
SWITCHES	
Battery master switch	●
Differential Lock	
FNR shifter	
Hazard	●
Parking	●
Pilot cut off	●
Selective catalytic reduction	●
Emergency steering	
MEMBRANE SWITCHES IN MONITOR	
Main light	●
Work light	●
Auto grease	
Quick coupler	●
Ride control	
Work load	●
Beacon light	
Rear wiper	
Mirror heat	●
Auto position	●
Fine modulation	●
IGNITION	
Key	●
Button	
CAB(SOUND SUPPRESSED)	
ROPS / FOPS CAB.	●
Cigar lighter & ashtray	
Coat hook	●
Rear view mirrors (1 Inside)	●
Rear view mirrors (2 Outside, heated)	●
Steering column, tilt and telescopic	●
Steering wheel with knob	●
Roller type sunshade (Front window)	●
Roller type sunshade (Rear window)	
Tinted safety glass	●
One door cab	●
Magazine pocket	●
Radio / USB player	●
Rubber floor mat	●
Wrist rest	●
24V to 12V DC converter (20A)	
DOOR	
Door and cab locks, one key	●
Doors, service access (Locking)	●
Doors, service access (Remote control)	
AUTOMATIC CLIMATE CONTROL	
Air conditioner & heater	●
Defroster	●
Intermittent wiper and washer, front and rear	●
SEAT	
2" Retractable seat belt & adjustable mechanical suspension (Heated)	●
2" Retractable seat belt & adjustable air suspension (Heated)	
3" Retractable seat belt & adjustable air suspension (Heated)	

STANDARD / OPTION

CAB & INTERIOR	STD
PERSONAL STORAGE SPACE	
Console box	●
Holder, can and cup	●
PEDALS	
One accelerator pedal	●
One brake pedal	●
Dual-brake pedal	
Accel pedal without ECO switch	●
Accel pedal with ECO switch	
ENGINE	
Alternator, 95A	●
Antifreeze	●
Fuel warmer	●
Fan guard	●
Rain cap, Engine air intake	●
Coolant Level Sight Gauge	●
3 Stage air precleaner	
ENGINE, CUMMINS, B4.5	
EU STAGE V / EPA TIER 4 FINAL	●
Fuel / water separator	●
Engine oil level dipstick gauge	●
CLEAN EMISSION MODULE	
DOC, DPF and SCR	●
POWER TRAIN	
TRANSMISSION	
Transmission F4/R3, computer controlled, electronic soft shift, auto-shift and kick-down features included	●
Transmission oil sight level	●
AXLE	
Open differential (Front / Rear)	●
Limited slip differential (Front / Rear)	
Hydraulic lock differential (Front)	
BRAKE	
Service brake (Enclosed wet-disc)	●
Parking brake	●
TIRES	
17.5 R25, ★★, L3	●
17.5 R25, ★, XHA	
17.5-25 12PR L3	
HYDRAULIC SYSTEM	
STD	
Auto Greasing	
Boom kickout, automatic	●
Bucket positioner, automatic	●
Diagnostic pressure taps	●
CONTROL	
Joystick	
Fingertip	
Electro Hydraulic Joystick	●
Electro Hydraulic Fingertip	
Extra piping for auxiliary function	
Hyundai Bio Hydraulic Oil(HBHO)	
Hydraulic oil level sight gauge	●
Quick coupler piping	●
Ride control system	

SAFETY	
Emergency stop	●
Fire extinguisher	
Alarm, back-up	●
Boom safety lock	
Emergency steering	●
OBJECT DETECTION	
IMOD(Intelligent Moving Object Detection)	
AVM(Around View Monitoring)	
RADAR + Secondary Monitor	
OTHERS	
Articulation locking bar	●
Air compressor	
Tool kit	
Lift and tie-down hooks	●
Loader linkage, sealed	●
Vandalism protection caplocks	●
BUCKET	
1.7m³ Bolt-on Cutting Edges Q/C type	●
1.9m³ Bolt-on Cutting Edges Q/C type	●
1.9m³ Bolt-on Cutting Edges type	●
1.8m³ 1 Piece Tooth type	
1.9m³ Q/C type	
COUNTERWEIGHT	
Counterweight	●
Drawbar with pin	●
ERGONOMICALLY LOCATED AND SLIP RESISTANT, LEFT & RIGHT	
Handrails	●
Ladders	●
Platforms	●
Steps	●
TELEMATICS	
Hi MATE	
ECD(Engine Connected Diagnostics)	●
GUARDS	
Crankcase	
Transmission	
Fenders (Front / Rear)	●
Mud guards	

* Standard and optional equipment may vary. Contact your Hyundai dealer for more information. The machine may vary according to International standards.
 * The photos may include attachments and optional equipment that are not available in your area.
 * Materials and specifications are subject to change without advance notice.
 * All imperial measurements rounded off to the nearest pound or inch.

MEMO