

HX160A L HX180A L

With EU Stage V Engine Installed

* Photo may include optional equipment.



Head Office(Sales Office)
14F, GLOBAL R&D CENTER, 477 BUNDANG SUSEO-RO, BUNDANG-GU, SEONGNAM-SI, GYEONGGI-DO, 13553, KOREA

PLEASE CONTACT

Gross Power
115 kW (155 HP) at 2,200 rpm

Net Power
113 kW (152 HP) at 2,200 rpm

Bucket Capacity
0.73 ~ 0.96m³

Operating Weight
X160A L : 17,695kg (39,010lb)
HX180A L : 18,665kg (41,150lb)

WHAT'S NEWEST AND BEST

HX160A L
HX180A L

THE BEST PRODUCTIVITY AND FUEL EFFICIENCY

- EU STAGE V Engine **NEW**
- Eco Report **NEW**
- Lifting Mode **NEW**
- IPC(Intelligent Power Control) **Upgrade**
- Fuel Rate Information
- Eco Gauge
- Automatic Engine Shutdown

NEW EXTERIOR DESIGN FOR ROBUSTNESS AND SAFETY

- Side Protector **Option**
- ROPS Cabin
- FOG Cabin **Option**
- Reinforced Durability of Upper and Lower Structure and Attachments
- Durable Cooling Module
- High-grade (High-pressure) Hoses

EASY CONTROL AND COMFORTABLE OPERATION

- Key On Init Work Mode **NEW**
- Visibility and Handle Improvement **NEW**
- One Pedal Travel Straight **Option**
- Proportional Auxiliary Hydraulic System **Option**
- 2 Way Proportional RCV & Pedal Control Selection **Option**
- Fine(Cushion/Free) Swing Control **Option**
- Intelligent & Wide Cluster
- Jog Dial Module
- OME(Owner Menu Editing)
- Boom/Arm Speed

THE ULTIMATE SAFE ENVIRONMENT

- Auto Safety Lock **NEW**
- AAVM Camera System **Option**
- Mirror View Camera **Option**
- Seatbelt Warning Alarm
- Cabin Viscous Mount
- Emergency Engine Stop Switch

SERVICEABILITY AND TELEMATICS

- Hi MATE **Option**
- ECD(Engine Connected Diagnostics) **NEW**
- Mobile Fleet App.
- HCE-DT Air **NEW**
- Longer Lasting Filter
- Improved Routine Maintenance



* Photo may include optional equipment.



EU STAGE V CERTIFIED ENGINE

Cummins B4.5 engine is satisfying the most strict environmental emission regulation in the world (Reduction in PM 60%)

EU STAGE V Engine NEW

Now in its fourth decade of continuous improvement, the B4.5 for 2019 features an EGR-free design that delivers 13 percent more power and 27 percent more peak torque than the current model. Increased fuel economy and longer maintenance intervals contribute to a reduced cost of operation.

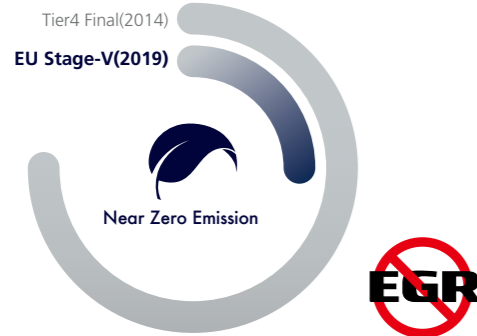

Lifting Mode NEW

This work mode improves fine operability and lift capability through RPM reduction, power boost activation and pump flow control.

IPC(Intelligent Power Control) Upgrade

HX A Series adopts the upgraded IPC system. It is able to optimize pump flow rate and power at the various working condition through the individual pump control. Furthermore, optimized design of MCV and pipe line minimizes energy loss such as conflux and throttle loss.



ENVIRONMENTALLY FRIENDLY FUEL EFFICIENCY

Eco Report NEW

It reports the excavator's inefficient operation status and help improving operator's working habit.



Fuel Rate Information

Fuel information is displayed as average rate and latest fuel consumed for guiding to economy operating.



Eco Gauge

Gauge level changes in accordance with engine working load and color indicates fuel saving-operation status.



Automatic Engine Shutdown

Adjustable 'Automatic Engine Shutdown' significantly reduces idle time, overall operating hours and fuel consumption.



THE BEST PRODUCTIVITY AND FUEL EFFICIENCY

HX A Series is equipped with eco-friendly, high-performance engines that meet the EU Stage V emission requirements.

BETTER FUEL-EFFICIENCY
(Compared to HX Series at P mode)

Leveling **5%**

Truck loading **5%**



* Photo may include optional equipment.



NEW EXTERIOR DESIGN FOR ROBUSTNESS AND SAFETY

The true value of HX A Series lies in its durability and high productivity. The robust upper and lower frame structure can endure external shock and heavy work loads. Attachment performance has been proven through rigorous field testing. No matter how tough the working environment is, you can always rely on the HYUNDAI Excavator HX A Series.



We make the best performance in rough working conditions without any unsureness with trustworthy HX160/180A L.



HX A Series is equipment with eco-friendly, high-performance engines that meet the EU Stage V emission requirement. Become a true leader on the ground with HX A Series.

ROPS / FOG Cabin

The cabin structure of Hyundai HX A Series is using integrally welded low-stress, high strength steel to meet ROPS and FOG certification.

- ROPS : Roll-Over Protective Structures ISO12117-2
- FOG : Falling Object Guard, ISO10262 Level2 **Option**



Reinforced Durability of Upper and Lower Structure and Attachments

The upper and lower structure and attachments of HX A Series have higher durability than demanded on the site, as proven through numerous tests including road tests and virtual simulation. The wear resistance of the bucket has been improved by use of new material.

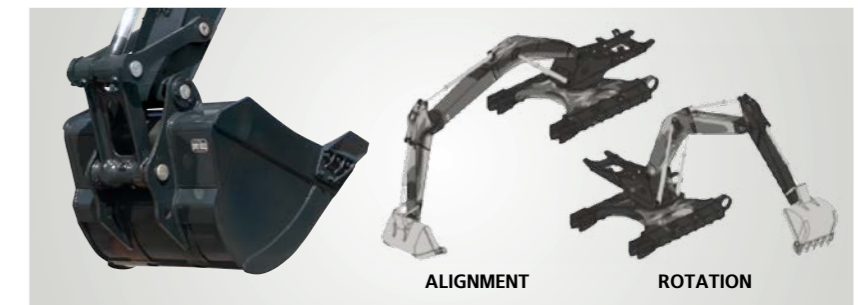

Durable Cooling Module

HX A Series has a durable cooling module that passed stringent tests, demonstrating the highest productivity in tough working environments.



Side Protector **Option**

Protect sides frame during operation in narrow area



Hi-grade (High-pressure) Hoses

The HX A Series uses high-pressure hoses with improved heat and pressure resistance, greatly increasing the durability of the equipment.

13%

CABIN SPACE FOR DRIVERS INCREASED BY



310mm
340mm



EASY CONTROL AND COMFORTABLE OPERATION

Many electronic functions are concentrated in the most convenient spot for operators to improve work efficiency. The highly-advanced infotainment system, a product of HCE's intensive information technology development, enables both productivity and comfort while working! HX A Series is designed with the operator in mind.

Intelligent & Wide Cluster

The 8" capacitive-type display(like smart-phone display) of HX A Series is delivering excellent legibility. The centralized switches on the display allow convenience of checking the urea level and temperature outside the cabin.

One Pedal Travel Straight Option

One pedal straight travel is available for customers' convenience when long distance traveling or combination of attachment work with traveling is necessary.



Proportional Auxiliary Hydraulic System Option

Proportional control switch with better speed control helps operators to enlarge the operation convenience whenever they do time-consuming work. And this function can be switched with pedal valve in cluster setting menu. Newly added detent function allows an operator to continue using 2 way piping flow even if the operator does not keep pressing proportional control switch.

Jog Dial Module

The integrated jog dial module applies to the accelerator, remote air conditioner controller and operation of the cluster, allowing convenient operation. In the event of failure of the jog dial module, the emergency mode is activated on the cluster to ensure fail-safe function.



Key On Init Work Mode NEW

Operator can maintain previously set about attachment mode when starting.



Visibility and Handle Improvement NEW

Visibility through cabin door is improved and handle design on the cabin door is also improved and offers better convenient while operator get on and off the cabin.



Fine (Cushion/Free) Swing control Option

This option enables smooth movement at the start and stop of swing operation(Cushion Swing). In addition, it reduces the shaking of the weight when lifting operation(Free Swing).

OME(Owner Menu Editing)

The Owner of machine can restrict operators access the set of functions. In the menu. Owner can set the list of the function to lock or unlock it. It is necessary to input the password to access the set of function.



Boom/Arm Speed

Boom-up speed compared to swing speed can be adjusted by activating/deactivating boom priority function. Arm-in speed can be also tuned by activating/deactivating arm regeneration function.

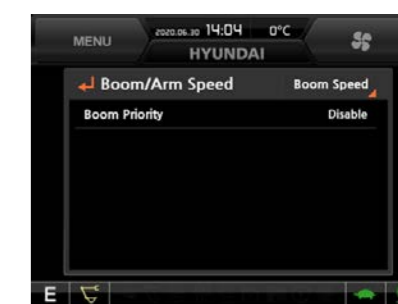

HX160/180A L with advanced technology ensures our safety on a construction site.



HX A Series excavators are products of HCE's spirit of initiative, creativity, and strong drive. HCE engineers, who are the best in the industry, have worked tirelessly to offer a zero-defect product. The new HX A Series reflects customers' needs in the field gleaned by thorough monitoring.

Auto Safety Lock **NEW**

It prevents unintended operation. If operator unlock safety lever when RCV lever is pressed, excavator is not controlled by RCV lever.

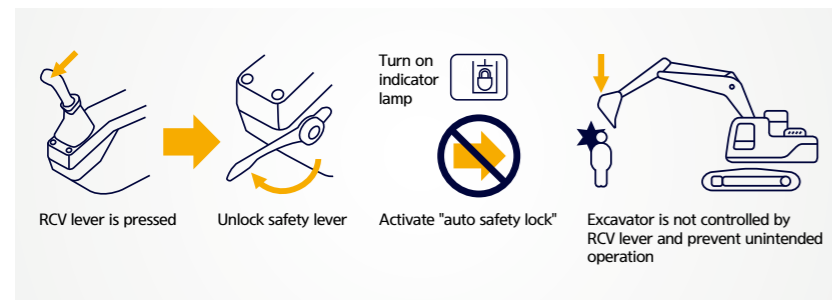

AAVM(Advanced Around View Monitoring) Camera System **Option**

HX A Series has a state-of-the-art AAVM video camera system to secure field of vision for operators in all directions, thereby preventing accidents. Operators can easily check the workplace in the front and rear and to the right and left.

- **AAVM**(Advanced Around View Monitoring) : Secure field of vision in all directions by ten views including 3D bird's eye view and 2D/4CH view.
- **IMOD**(Intelligent Moving Object Detection) : Inform when people or dangerous objects are detected within the range of operation(recognition distance : 5 m).



Mirror View Camera **Option**

Simple type mirror view with rear view camera option is available. This option helps the operator cover visual blind spot on the right side.



Seatbelt Warning Alarm

If the seatbelt is not buckled when the ignition key is turned, an alarm is triggered in intervals along with a continuous visual alert. This emphasises our priority for operator safety.

Cabin Viscous Mount

With a low-vibration design by the coil spring and damper inside the mount, the cabin viscous mount of HX A Series reduces noise inside the cabin and improves durability, providing a comfortable operation space that lessens operators' fatigue.

Emergency Engine Stop Switch

Manual engine stop switch behind the seat is used for emergency stop. It can be reached from outside of cabin.



THE ULTIMATE SAFE ENVIRONMENT

The true value of HX A Series lies in its durability. The robust frame structure and the attachments show the real value of HX A Series in tough working environments and promise higher productivity.

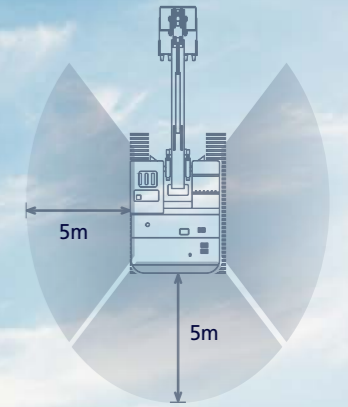

AAVM Camera System **Option**



*Photo may include optional equipment.



SERVICEABILITY AND TELEMATICS

IoT / ICT / AI-based digital technology.
Creating a smart construction site. Maximizes connectivity, productivity, and safety for successful businesses.



Hi MATE

Option

IT'S CONVENIENT, EASY AND VALUABLE

Hi MATE Hyundai's newly developed remote management system, utilizes GPS-satellite technology to provide customers with the highest level of service and product support available. Hi MATE enables users to remotely evaluate machine performance, access diagnostic information, and verify machine locations at the touch of a button.

WHAT IS BENEFITS



Increase Productivity

It helps you operate machines in efficient. You can check the difference between total engine hours and actual working hours. See how productive your machines are and plan any required cost saving solutions. Hi MATE offers working information such as working / idling hours, fuel consumption and rate.



Convenient and Easy Monitoring

There is nothing much to do to monitor your machines. Just log on to the Hi MATE website or mobile application. Hi MATE allows you to watch your machines whenever and wherever you are.



Security

Protect your machines from theft or unauthorized usage with Hi MATE. If the machine moves out of the Geofence boundary, you will get alerts.

ECD(Engine Connected Diagnostics) Option

ECD will support the after sales technicians and dealers with a diagnostics report (via e-mail, mobile, app or Hi MATE) on the engine performance. This will help after sales technicians arrive on site with the necessary tools and parts to fix troubles in one visit.

ECD is an integrated remote diagnostics service between Cummins cloud and Hi MATE cloud.

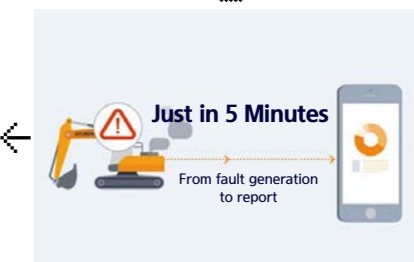
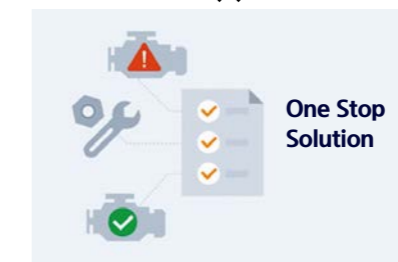

Mobile Fleet App. Option

The new Mobile App is optimized to fleet management. It provides productivity, health insights based on telematics technology and enables fleet owner just focus on most wanted equipment in view of economical usage, utilization, fault codes and maintenance. The new Mobile App sorts equipment in order of eco-index, utilization-index and fault code level automatically so that urgent equipment pops up automatically.

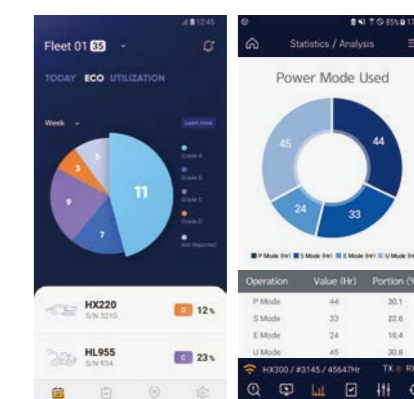

Hi MATE Fleet App HCE-DT AIR App

HCE-DT Air NEW

HCE-DT Air connects you and your equipment wirelessly via smartphone and laptop right on site. You can diagnose root causes and troubleshoot for fault codes through the connection.

Longer Lasting Filter

The length of product life period is improved. (when using CK4 engine oil)

Item	HX160/180L	HX160/180A L
Engine Oil	500 hrs	800 hrs
Engine Oil Filter	500 hrs	800 hrs
Fuel filter & Pre-filter	500 hrs	1000 hrs

Improved Routine Maintenance

Easy access for maintenance means regular checks get done faster, giving you more uptime and reducing operating costs. Ground-line access to filters, lube fittings and master switch makes service more convenient on HX A Series.

*Photo may include optional equipment.

SPECIFICATIONS

ENGINE

Maker / Model	Cummins B4.5
Type	4-cycle, turbocharged, charge air cooled, electronic
Gross Power (SAE J1995)	115 kW (155 HP) at 2,200 rpm
Net Power (SAE J1349)	113 kW (152 HP) at 2,200 rpm
Max. Power	115 kW (155 hp) at 2,000 rpm
Peak Torque	712 N · m (525 lb · ft) at 1,200 rpm
Displacement	4.5 l (275 cu in)

HYDRAULIC SYSTEM

MAIN PUMP	
Type	Variable displacement tandem axis piston pumps
Max. Flow	2 × 160 lpm (42.3 U.S. gpm)

PILOT PUMP	
Type	Fixed displacement gear pump single stage
Max. Flow	29 lpm (7.7 U.S. gpm)

HYDRAULIC MOTORS	
Travel	Variable displacement axial piston motor
Swing	Fixed displacement axial piston motor

RELIEF VALVE SETTING	
Implement Circuits	350 kgf/cm ² (4,980 psi)
Travel	350 kgf/cm ² (4,980 psi)
Power Boost (Boom, Arm, Bucket)	380 kgf/cm ² (5,410 psi)
Swing Circuit	285 kgf/cm ² (4,060 psi)
Pilot Circuit	40 kgf/cm ² (569 psi)
Service Valve	Installed

HYDRAULIC CYLINDERS	
No. of Cylinder Bore X Stroke	Boom : 2-∅115 × 1,090 mm
	Arm : 1-∅120 × 1,355 mm
No. of Cylinder Bore X Stroke	Bucket : 1-∅110 × 995 mm
	Blade : 2-∅110 × 320 mm
	2PCS 1st : 2-∅110 × 995 mm
	2nd : 1-∅160 × 650 mm

* Hyundai Bio Hydraulic Oil (HBHO) available.

DRIVES & BRAKES

Drive Method	Fully hydrostatic type
Drive Motor	Axial piston motor, in-shoe design
Reduction System	Planetary reduction gear
Max. Drawbar Pull	16,700 kgf (36,820 lbf)
Max. Travel Speed (High / Low)	3.1 km/hr (1.9 mph) / 5.4 km/hr (3.4 mph)
Gradeability	35° (70%)
Parking Brake	Multi wet disc

CONTROL

Pilot pressure operated joysticks and pedals with detachable lever provide almost effortless and fatigueless operation.

Pilot Control	Two joysticks with one safety lever (LH) : Swing and arm, (RH) : Boom and bucket
Traveling and Steering	Two levers with pedals
Engine Throttle	Electric, dial type

SWING SYSTEM

Swing Motor	Fixed displacement axial piston motor
Swing Reduction	Planetary reduction gear
Swing Bearing Lubrication	Grease-bathed
Swing Brake	Multi wet disc
Swing Speed	10.3 rpm

SERVICE CAPACITIES

	liter	US gal
Fuel Tank	290	76.6
Engine Coolant	23	6.1
Engine Oil	11	2.9
Swing Device	6.2	1.6
Final Drive (Each)	6	1.6
Hydraulic System (Including Tank)	255	67.4
Hydraulic Tank	125	33.0
Def/Adblue®	35	9.2

UNDERCARRIAGE

The X-leg type center frame is integrally welded with reinforced box-section track frames. The undercarriage includes lubricated rollers, idlers, track adjusters with shock absorbing springs and sprockets, and a track chain with double or triple grouser shoes.

Center Frame	X - Leg Type	
Track Frame	Pentagonal Box Type	
	HX160A L	HX180A L
No. of Shoes on Each Side	49	51
No. of Carrier Roller	2 x 2	2 x 2
No. of Track Roller	2 x 7	2 x 7
No. of Rail Guard	2 x 1	2 x 1

OPERATING WEIGHT (APPROXIMATE)

Operating weight, including 5,100 mm (16' 9") boom, 2,600 mm (8' 6") arm, SAE heaped 0.73 m³ (0.95 yd³) bucket, lubricant, coolant, full fuel tank, full hydraulic tank, and all standard equipments.

OPERATING WEIGHT

Shoes	Type	Width mm(in)	Operating Weight		Ground Pressure kgf/cm ² (psi)
			kg (lb)		
Triple Grouser	500 (20")	HX160A L	17,455 (38,480)	0.51 (7.24)	
			HX160A L Dozer	18,540 (40,870)	0.54 (7.69)
		HX180A L	18,140 (39,990)	0.50 (7.13)	
			HX180A L Dozer	19,235 (42,410)	0.53 (7.56)
		600 (24")	HX160A L	17,695 (39,010)	0.43 (6.12)
				HX160A L Dozer	18,775 (41,390)
	HX180A L		18,400 (40,570)	0.42 (6.03)	
			HX180A L Dozer	19,505 (43,000)	0.45 (6.39)
	700 (28")		HX160A L	17,945 (39,560)	0.37 (5.32)
				HX160A L Dozer	19,050 (42,000)
		HX180A L	18,665 (41,150)	0.37 (5.24)	
			HX180A L Dozer	19,780 (43,610)	0.39 (5.55)
800 (32")		HX180A L	18,920 (41,710)	0.33 (4.65)	
			HX180A L Dozer	19,985 (44,060)	0.35 (4.91)

AIR CONDITIONING SYSTEM

The air condition system for the machine contains the fluorinated greenhouse gas with global warming potential of R134a. (Global Warming Potential : 1,430) The system hold 0.75kg refrigerant consisting of a CO₂ of 1.07 metric tonnes. For more information, Please refer to the manual.

DIMENSIONS & WORKING RANGE

HX160A L / HX180A L MONO BOOM DIMENSIONS

5.10 m (16' 9") BOOM and 2.20 m (7' 3"), 2.60 m (8' 6"), 3.10 m (10' 2") ARM

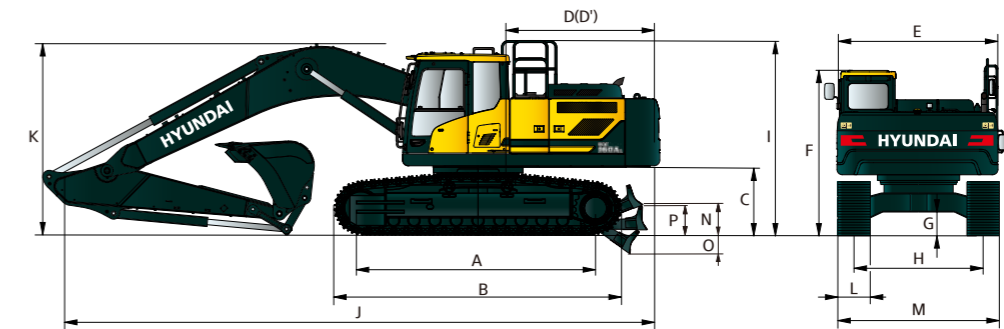

Unit : mm (ft-in)

	HX160A L	HX180A L	Boom Length 5,100 (16' 9")	
A Tumbler Distance	3,170 (10' 5")	3,360 (11' 0")		
B Overall Length of Crawler	3,910 (12' 10")	4,100 (13' 5")		
*C Ground Clearance of Counter Weight	1,060 (3' 6")	1,060 (3' 6")		
D Tail Swing Radius	2,490 (8' 2")	2,490 (8' 2")		
D' Rear-End Length	2,490 (8' 2")	2,490 (8' 2")		
E Overall Width of Upper Structure	2,475 (8' 1")	2,475 (8' 1")		
*F Overall Height of Cab	2,980 (9' 9")	2,980 (9' 9")		
*G Min. Ground Clearance	460 (1' 6")	460 (1' 6")		
H Track gauge	1,990 (6' 6")	2,250 (7' 5")		
*I Overall Height of Guardrail	3,250 (10' 8")	3,250 (10' 8")		
			J Overall Length	
			K Overall Height of Boom	
			L Track Shoe	
			M Overall Width	
			N** Ground clearance of blade up	
			O** Depth of blade down	
			P** Height of blade	

* This figure includes the size of grousers.
**With dozer blade option

HX160A L / HX180A L MONO BOOM WORKING RANGE

Unit : mm (ft-in)

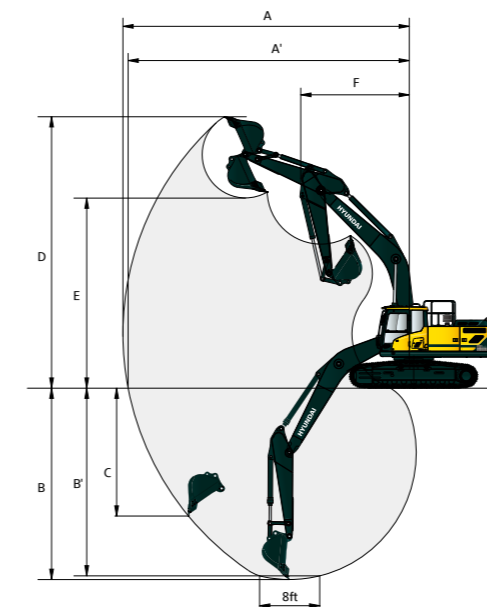

	Boom Length 5,100 (16' 9")		
Boom Length	5,100 (16' 9")		
Arm Length	2,200 (7' 3")	2,600 (8' 6")	3,100 (10' 2")
A Max. Digging Reach	8,690 (28' 6")	9,020 (29' 7")	9,450 (31' 0")
A' Max. Digging Reach on Ground	8,530 (28' 0")	8,860 (29' 1")	9,300 (30' 6")
B Max. Digging Depth	5,630 (18' 6")	6,030 (19' 9")	6,530 (21' 5")
B' Max. Digging Depth (8' Level)	5,410 (17' 9")	5,825 (19' 1")	6,340 (20' 10")
C Max. Vertical Wall Digging Depth *	3,410 (11' 2")	3,600 (11' 10")	3,845 (12' 7")
D Max. Digging Height	8,670 (28' 5")	8,750 (28' 8")	8,880 (29' 2")
E Max. Dumping Height	6,140 (20' 2")	6,250 (20' 6")	6,410 (21' 0")
F Min. Swing Radius	3,180 (10' 5")	3,170 (10' 5")	3,160 (10' 4")

* This dimension varies with kinds of buckets.

DIMENSIONS & WORKING RANGE

HX160A L / HX180A L 2-PIECE BOOM DIMENSIONS

5.10 m (16' 9") BOOM and 2.20 m (7' 3"), 2.60 m (8' 6") ARM

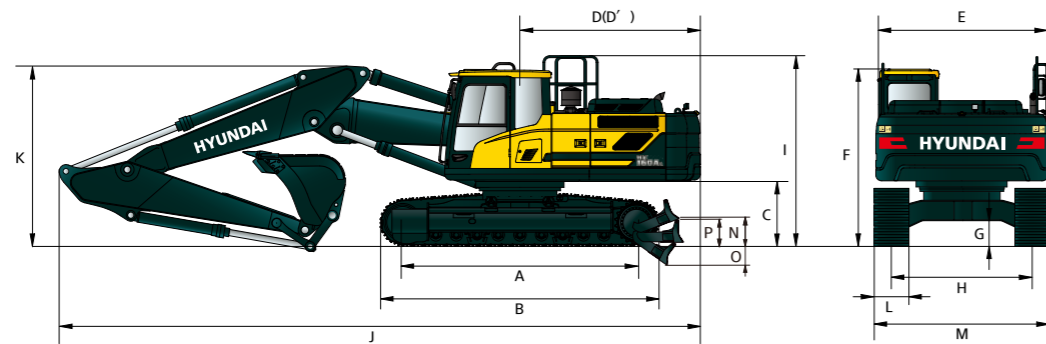

Unit : mm (ft-in)

	HX160A L	HX180A L	Boom Length 5,100 (16' 9")			
A Tumbler Distance	3,170 (10' 5")	3,360 (11' 0")	2,200 (7' 3") 2,600 (8' 6")			
B Overall Length of Crawler	3,910 (12' 10")	4,100 (13' 5")	8,585 (28' 2") 8,575 (28' 2")			
*C Ground Clearance of Counter Weight	1,060 (3' 6")	1,060 (3' 6")	3,035 (9' 11") 3,060 (10' 0")			
D Tail Swing Radius	2,490 (8' 2")	2,490 (8' 2")	500 (20") 600 (24") 700 (28") 800 (32")			
D' Rear-End Length	2,490 (8' 2")	2,490 (8' 2")	HX 160A L 2,490 (8' 2") 2,590 (8' 6") 2,690 (8' 10") -			
E Overall Width of Upper Structure	2,475 (8' 1")	2,475 (8' 1")	HX 180A L 2,750 (9' 0") 2,850 (9' 4") 2,950 (9' 8") 3,050 (10' 0")			
*F Overall Height of Cab	2,980 (9' 9")	2,980 (9' 9")	N** Ground clearance of blade up 615 (2' 0")			
*G Min. Ground Clearance	460 (1' 6")	460 (1' 6")	O** Depth of blade down 670 (2' 2")			
H Track gauge	1,990 (6' 6")	2,250 (7' 5")	P** Height of blade 640 (2' 1")			
*I Overall Height of Guardrail	3,250 (10' 8")	3,250 (10' 8")				

* This figure includes the size of grousers.
**With dozer blade option

HX160A L / HX180A L 2-PIECE BOOM WORKING RANGE

Unit : mm (ft-in)

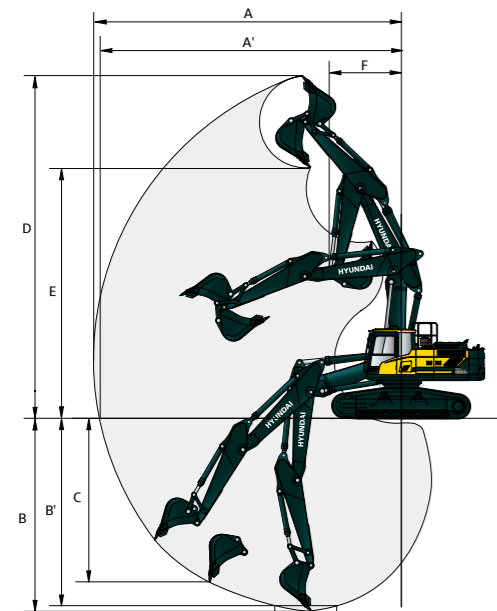

	Boom Length 5,100 (16' 9")	
Arm Length	2,200 (7' 3")	2,600 (8' 6")
A Max. Digging Reach	8,760 (28' 9")	9,110 (29' 11")
A' Max. Digging Reach on Ground	8,600 (28' 3")	8,955 (29' 5")
B Max. Digging Depth	5,305 (17' 5")	5,690 (18' 8")
B' Max. Digging Depth (8' Level)	5,200 (17' 1")	5,590 (18' 4")
C Max. Vertical Wall Digging Depth *	3,520 (11' 7")	3,790 (12' 5")
D Max. Digging Height	9,380 (30' 9")	9,560 (31' 4")
E Max. Dumping Height	6,720 (22' 1")	6,920 (22' 8")
F Min. Swing Radius	3,090 (10' 2")	2,970 (9' 9")

* This dimension varies with kinds of buckets.

LIFTING CAPACITY

Rating over-front Rating over-side or 360 degree

HX160A L MONO BOOM

5.10 m (16' 9") boom, 2.20 m (7' 3") arm equipped with 2,600kg counter weight, 600mm(24") Triple grouser shoe and without Dozer.

Lift-point height (m/ft)	Lift-point radius								At max. reach		
	1.5 m (4.9 ft)		3.0 m (9.8 ft)		4.5 m (14.8 ft)		6.0 m (19.7 ft)		Capacity	Reach	
6.0 m (19.7 ft)	kg								*3,850	3,340	5.86
	lb								*8,490	7,360	(19.2)
4.5 m (14.8 ft)	kg			*5,320	5,000	*4,750	3,200		*3,630	2,630	6.74
	lb			*11,730	11,020	*10,470	7,050		*8,000	5,800	(22.1)
3.0 m (9.8 ft)	kg			*6,540	4,670	4,990	3,070		*3,650	2,310	7.20
	lb			*14,420	10,300	11,000	6,770		*8,050	5,090	(23.6)
1.5 m (4.9 ft)	kg			7,500	4,360	4,840	2,940		3,600	2,200	7.33
	lb			16,530	9,610	10,670	6,480		7,940	4,850	(24.0)
0.0m (0.0ft)	kg			7,310	4,200	4,730	2,840		3,700	2,250	7.13
	lb			16,120	9,260	10,430	6,260		8,160	4,960	(23.4)
-1.5 m (-4.9 ft)	kg			*9,400	7,730	7,270	4,170		4,150	2,510	6.58
	lb			*20,720	17,040	16,030	9,190		9,150	5,530	(21.6)
-3.0 m (-9.8 ft)	kg			*9,400	7,900	*6,720	4,250		*4,980	3,200	5.58
	lb			*20,720	17,420	*14,820	9,370		*10,980	7,050	(18.3)

5.10 m (16' 9") boom, 2.20 m (7' 3") arm equipped with 2,600 kg counter weight, 600 mm (24") Triple grouser shoe and with Dozer up.

Lift-point height (m/ft)	Lift-point radius								At max. reach		
	1.5 m (4.9 ft)		3.0 m (9.8 ft)		4.5 m (14.8 ft)		6.0 m (19.7 ft)		Capacity	Reach	
6.0 m (19.7 ft)	kg								*3,850	3,530	5.86
	lb								*8,490	7,780	(19.2)
4.5 m (14.8 ft)	kg			*5,320	5,270	*4,750	3,380		*3,630	2,790	6.74
	lb			*11,730	11,620	*10,470	7,450		*8,000	6,150	(22.1)
3.0 m (9.8 ft)	kg			*6,540	4,940	4,950	3,260		*3,650	2,460	7.20
	lb			*14,420	10,890	10,910	7,190		*8,050	5,420	(23.6)
1.5 m (4.9 ft)	kg			7,430	4,630	4,790	3,120		3,570	2,350	7.33
	lb			16,380	10,210	10,560	6,880		7,870	5,180	(24.0)
0.0m (0.0ft)	kg			7,240	4,460	4,690	3,030		3,670	2,400	7.13
	lb			15,960	9,830	10,340	6,680		8,090	5,290	(23.4)
-1.5 m (-4.9 ft)	kg			*9,400	8,200	7,200	4,430		4,110	2,680	6.58
	lb			*20,720	18,080	15,870	9,770		9,060	5,910	(21.6)
-3.0 m (-9.8 ft)	kg			*9,400	8,370	*6,720	4,520		*4,980	3,400	5.58
	lb			*20,720	18,450	*14,820	9,960		*10,980	7,500	(18.3)

5.10 m (16' 9") boom, 2.20 m (7' 3") arm equipped with 2,600 kg counter weight, 600 mm (24") Triple grouser shoe and with Dozer down.

Lift-point height (m/ft)	Lift-point radius								At max. reach		
	1.5 m (4.9 ft)		3.0 m (9.8 ft)		4.5 m (14.8 ft)		6.0 m (19.7 ft)		Capacity	Reach	
6.0 m (19.7 ft)	kg								*3,850	3,530	5.86
	lb								*8,490	7,780	(19.2)
4.5 m (14.8 ft)	kg			*5,320	5,270	*4,750	3,380		*3,630	2,790	6.74
	lb			*11,730	11,620	*10,470	7,450		*8,000	6,150	(22.1)
3.0 m (9.8 ft)	kg			*6,540	4,940	*5,200	3,260		*3,650	2,460	7.20
	lb			*14,420	10,890	*11,460	7,190		*8,050	5,420	(23.6)
1.5 m (4.9 ft)	kg			*7,690	4,630	*5,710	3,120		*3,850	2,350	7.33
	lb			*16,950	10,210	*12,590	6,880		*8,490	5,180	(24.0)
0.0m (0.0ft)	kg			*8,180	4,460	*5,980	3,030		*4,310	2,400	7.13
	lb			*18,030	9,830	*13,180	6,680		*9,500	5,290	(23.4)
-1.5 m (-4.9 ft)	kg			*9,400	8,200	*7,910	4,430		*5,030	2,680	6.58
	lb			*20,720	18,080	*17,440	9,770		*11,090	5,910	(21.6)
-3.0 m (-9.8 ft)	kg			*9,400	8,370	*6,720	4,520		*4,980	3,400	5.58
	lb			*20,720	18,450	*14,820	9,960		*10,980	7,500	(18.3)

- 1 | Lifting capacity are based on ISO 10567.
- 2 | Lifting capacity of HX Series does not exceed 75% of tipping load with the machine on firm, level ground or 87% of full hydraulic capacity.
- 3 | The Lift-point is bucket pivot mounting pin on the arm (without bucket mass).
- 4 | (*) indicates load limited by hydraulic capacity.

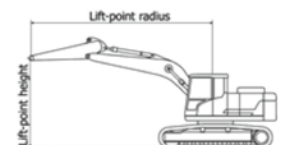

LIFTING CAPACITY

Rating over-front Rating over-side or 360 degree

Rating over-front Rating over-side or 360 degree

HX160A L MONO BOOM

5.10 m (16' 9") boom, 2.20 m (7' 3") arm equipped with 3,250 kg counter weight, 600mm(24") Triple grouser shoe and without Dozer.

Lift-point height (m/ft)		Lift-point radius								At max. reach		
		1.5 m (4.9 ft)		3.0 m (9.8 ft)		4.5 m (14.8 ft)		6.0 m (19.7 ft)		Capacity	Reach	
												m (ft)
6.0 m (19.7 ft)	kg									*3,850	3,690	5.86
	lb									*8,490	8,140	(19.2)
4.5 m (14.8 ft)	kg			*5,320	*5,320	*4,750	3,530			*3,630	2,920	6.74
	lb			*11,730	*11,730	*10,470	7,780			*8,000	6,440	(22.1)
3.0 m (9.8 ft)	kg			*6,540	5,160	*5,200	3,410			*3,650	2,580	7.20
	lb			*14,420	11,380	*11,460	7,520			*8,050	5,690	(23.6)
1.5 m (4.9 ft)	kg			*7,690	4,840	5,270	3,270			*3,850	2,470	7.33
	lb			*16,950	10,670	11,620	7,210			*8,490	5,450	(24.0)
0.0m (0.0ft)	kg			7,960	4,680	5,160	3,180			4,050	2,530	7.13
	lb			17,550	10,320	11,380	7,010			8,930	5,580	(23.4)
-1.5 m (-4.9 ft)	kg			*9,400	8,590	*7,910	4,650	5,140	3,160	4,530	2,810	6.58
	lb			*20,720	18,940	*17,440	10,250	11,330	6,970	9,990	6,190	(21.6)
-3.0 m (-9.8 ft)	kg			*9,400	8,760	*6,720	4,740			*4,980	3,570	5.58
	lb			*20,720	19,310	*14,820	10,450			*10,980	7,870	(18.3)

5.10 m (16' 9") boom, 2.20 m (7' 3") arm equipped with 3,250 kg counter weight, 600 mm (24") Triple grouser shoe and with Dozer up.

Lift-point height (m/ft)		Lift-point radius								At max. reach		
		1.5 m (4.9 ft)		3.0 m (9.8 ft)		4.5 m (14.8 ft)		6.0 m (19.7 ft)		Capacity	Reach	
												m (ft)
6.0 m (19.7 ft)	kg									*3,850	*3,850	5.86
	lb									*8,490	*8,490	(19.2)
4.5 m (14.8 ft)	kg			*5,320	*5,320	*4,750	3,720			*3,630	3,080	6.74
	lb			*11,730	*11,730	*10,470	8,200			*8,000	6,790	(22.1)
3.0 m (9.8 ft)	kg			*6,540	5,420	*5,200	3,600			*3,650	2,730	7.20
	lb			*14,420	11,950	*11,460	7,940			*8,050	6,020	(23.6)
1.5 m (4.9 ft)	kg			*7,690	5,110	5,230	3,460			*3,850	2,610	7.33
	lb			*16,950	11,270	11,530	7,630			*8,490	5,750	(24.0)
0.0m (0.0ft)	kg			7,890	4,950	5,120	3,360			4,010	2,680	7.13
	lb			17,390	10,910	11,290	7,410			8,840	5,910	(23.4)
-1.5 m (-4.9 ft)	kg			*9,400	9,060	7,860	4,920	5,100	3,340	4,490	2,980	6.58
	lb			*20,720	19,970	17,330	10,850	11,240	7,360	9,900	6,570	(21.6)
-3.0 m (-9.8 ft)	kg			*9,400	9,230	*6,720	5,000			*4,980	3,770	5.58
	lb			*20,720	20,350	*14,820	11,020			*10,980	8,310	(18.3)

5.10 m (16' 9") boom, 2.20 m (7' 3") arm equipped with 3,250 kg counter weight, 600 mm (24") Triple grouser shoe and with Dozer down.

Lift-point height (m/ft)		Lift-point radius								At max. reach		
		1.5 m (4.9 ft)		3.0 m (9.8 ft)		4.5 m (14.8 ft)		6.0 m (19.7 ft)		Capacity	Reach	
												m (ft)
6.0 m (19.7 ft)	kg									*3,850	*3,850	5.86
	lb									*8,490	*8,490	(19.2)
4.5 m (14.8 ft)	kg			*5,320	*5,320	*4,750	3,720			*3,630	3,080	6.74
	lb			*11,730	*11,730	*10,470	8,200			*8,000	6,790	(22.1)
3.0 m (9.8 ft)	kg			*6,540	5,420	*5,200	3,600			*3,650	2,730	7.20
	lb			*14,420	11,950	*11,460	7,940			*8,050	6,020	(23.6)
1.5 m (4.9 ft)	kg			*7,690	5,110	*5,710	3,460			*3,850	2,610	7.33
	lb			*16,950	11,270	*12,590	7,630			*8,490	5,750	(24.0)
0.0m (0.0ft)	kg			*8,180	4,950	*5,980	3,360			*4,310	2,680	7.13
	lb			*18,030	10,910	*13,180	7,410			*9,500	5,910	(23.4)
-1.5 m (-4.9 ft)	kg			*9,400	9,060	*7,910	4,920	5,770	3,340	*5,030	2,980	6.58
	lb			*20,720	19,970	*17,440	10,850	*12,720	7,360	*11,090	6,570	(21.6)
-3.0 m (-9.8 ft)	kg			*9,400	9,230	*6,720	5,000			*4,980	3,770	5.58
	lb			*20,720	20,350	*14,820	11,020			*10,980	8,310	(18.3)

1 | Lifting capacity are based on ISO 10567.

2 | Lifting capacity of HX Series does not exceed 75% of tipping load with the machine on firm, level ground or 87% of full hydraulic capacity.

3 | The Lift-point is bucket pivot mounting pin on the arm(without bucket mass).

4 | (*) indicates load limited by hydraulic capacity.

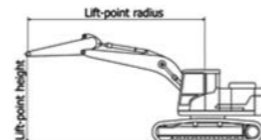

HX160A L MONO BOOM

5.10 m (16' 9") boom, 2.60 m (8' 6") arm equipped with 2,600kg counter weight, 600mm(24") Triple grouser shoe and without Dozer.

Lift-point height (m/ft)		Lift-point radius										At max. reach				
		1.5 m (4.9 ft)		3.0 m (9.8 ft)		4.5 m (14.8 ft)		6.0 m (19.7 ft)		7.5 m (24.6 ft)		Capacity	Reach			
														m (ft)		
7.5 m (24.6 ft)	kg												*3,410	*3,410	4.85	
	lb												*7,520	*7,520	(15.9)	
6.0 m (19.7 ft)	kg							*3,840	3,280					*2,970	*2,970	6.27
	lb							*8,470	7,230					*6,550	*6,550	(20.6)
4.5 m (14.8 ft)	kg					*4,870	*4,870	*4,430	3,230					*2,850	2,430	7.10
	lb					*10,740	*10,740	*9,770	7,120					*6,280	5,360	(23.3)
3.0 m (9.8 ft)	kg			*9,370	8,720	*6,120	4,740	*4,940	3,090	*3,110	2,170			*2,880	2,150	7.54
	lb			*20,660	19,220	*13,490	10,450	*10,890	6,810	*6,860	4,780			*6,350	4,740	(24.7)
1.5 m (4.9 ft)	kg					*7,380	4,390	4,840	2,940	3,470	2,120			*3,060	2,050	7.66
	lb					*16,270	9,680	10,670	6,480	7,650	4,670			*6,750	4,520	(25.1)
0.0m (0.0ft)	kg			*5,290	*5,290	7,300	4,190	4,720	2,820					*3,420	2,080	7.47
	lb			*11,660	*11,660	16,090	9,240	10,410	6,220					*7,540	4,590	(24.5)
-1.5 m (-4.9 ft)	kg	*5,090	*5,090	*9,190	7,630	7,230	4,120	4,670	2,780					3,800	2,290	6.95
	lb	*11,220	*11,220	*20,260	16,820	15,940	9,080	10,300	6,130					8,380	5,050	(22.8)
-3.0 m (-9.8 ft)	kg	*9,360	*9,360	*10,170	7,770	*7,120	4,180	4,740	2,840					4,720	2,830	6.01
	lb	*20,640	*20,640	*22,420	17,130	*15,700	9,220	10,450	6,260					10,410	6,240	(19.7)
-4.5 m (-14.8 ft)	kg			*6,860	*6,860									*4,560	*4,560	4.39
	lb			*15,120	*15,120									*10,050	*10,050	(14.4)

5.10 m (16' 9") boom, 2.60 m (8' 6") arm equipped with 2,600 kg counter weight, 600 mm (24") Triple grouser shoe and with Dozer up.

Lift-point height (m/ft)		Lift-point radius										At max. reach				
		1.5 m (4.9 ft)		3.0 m (9.8 ft)		4.5 m (14.8 ft)		6.0 m (19.7 ft)		7.5 m (24.6 ft)		Capacity	Reach			
														m (ft)		
7.5 m (24.6 ft)	kg												*3,410	*3,410	4.85	
	lb												*7,520	*7,520	(15.9)	
6.0 m (19.7 ft)	kg							*3,840	3,460					*2,970	*2,970	6.27
	lb							*8,470	7,630					*6,550	*6,550	(20.6)
4.5 m (14.8 ft)	kg					*4,870	*4,870	*4,430	3,410					*2,850	2,580	7.10
	lb					*10,740	*10,740	*9,770	7,520					*6,280	5,690	(23.3)
3.0 m (9.8 ft)	kg			*9,370	9,190	*6,120	5,000	*4,940	3,280	*3,110	2,310			*2,880	2,290	7.54
	lb			*20,660	20,260	*13,490	11,020	*10,890	7,230	*6,860	5,090			*6,350	5,050	(24.7)
1.5 m (4.9 ft)	kg					*7,380	4,660	4,800	3,120	3,430	2,260			*3,060	2,190	7.66
	lb					*16,270	10,270	10,580	6,880	7,560	4,980			*6,750	4,830	(25.1)
0.0m (0.0ft)	kg			*5,290	*5,290	7,230	4,450	4,670	3,010					3,410	2,230	7.47
	lb			*11,660	*11,660	15,940	9,810	10,300	6,640					7,520	4,920	(24.5)
-1.5 m (-4.9 ft)	kg	*5,090	*5,090	*9,190	8,100	7,160	4,390	4,620	2,960					3,760	2,450	6.95
	lb	*11,22														

LIFTING CAPACITY

Rating over-front Rating over-side or 360 degree

Rating over-front Rating over-side or 360 degree

HX160A L MONO BOOM

5.10 m (16' 9") boom, 3.10 m (10' 2") arm equipped with 3,250kg counter weight, 600mm(24") Triple grouser shoe and without Dozer.

Lift-point height (m/ft)	Lift-point radius										At max. reach		
	1.5 m (4.9 ft)		3.0 m (9.8 ft)		4.5 m (14.8 ft)		6.0 m (19.7 ft)		7.5 m (24.6 ft)		Capacity		Reach
													m (ft)
7.5 m (24.6 ft)	kg										*2,710	*2,710	5.51
	lb										*5,970	*5,970	(18.1)
6.0 m (19.7 ft)	kg						*3,700	*3,700			*2,430	*2,430	6.79
	lb						*8,160	*8,160			*5,360	*5,360	(22.3)
4.5 m (14.8 ft)	kg						*4,020	3,600	*2,570	2,480	*2,340	*2,340	7.56
	lb						*8,860	7,940	*5,670	5,470	*5,160	*5,160	(24.8)
3.0 m (9.8 ft)	kg		*7,930	*7,930	*5,540	5,300	*4,580	3,440	*3,790	2,430	*2,380	2,190	7.97
	lb		*17,480	*17,480	*12,210	11,680	*10,100	7,580	*8,360	5,360	*5,250	4,830	(26.2)
1.5 m (4.9 ft)	kg		*6,760	*6,760	*6,920	4,910	*5,230	3,270	3,770	2,350	*2,530	2,090	8.09
	lb		*14,900	*14,900	*15,260	10,820	*11,530	7,210	8,310	5,180	*5,580	4,610	(26.5)
0.0m (0.0ft)	kg		*6,160	*6,160	*7,830	4,650	5,120	3,130	3,700	2,290	*2,820	2,120	7.91
	lb		*13,580	*13,580	*17,260	10,250	11,290	6,900	8,160	5,050	*6,220	4,670	(25.9)
-1.5 m (-4.9 ft)	kg	*4,790	*4,790	*8,770	8,340	7,810	4,530	5,040	3,050		*3,360	2,300	7.42
	lb	*10,560	*10,560	*19,330	18,390	17,220	9,990	11,110	6,720		*7,410	5,070	(24.3)
-3.0 m (-9.8 ft)	kg	*8,080	*8,080	*10,910	8,440	*7,450	4,550	5,060	3,070		4,480	2,750	6.55
	lb	*17,810	*17,810	*24,050	18,610	*16,420	10,030	11,160	6,770		9,880	6,060	(21.5)
-4.5 m (-14.8 ft)	kg			*8,260	*8,260	*5,640	4,710				*4,650	3,970	5.11
	lb			*18,210	*18,210	*12,430	10,380				*10,250	8,750	(16.8)

5.10 m (16' 9") boom, 3.10 m (10' 2") arm equipped with 3,250kg counter weight, 600mm(24") Triple grouser shoe and with Dozer up.

Lift-point height (m/ft)	Lift-point radius										At max. reach		
	1.5 m (4.9 ft)		3.0 m (9.8 ft)		4.5 m (14.8 ft)		6.0 m (19.7 ft)		7.5 m (24.6 ft)		Capacity		Reach
													m (ft)
7.5 m (24.6 ft)	kg										*2,710	*2,710	5.51
	lb										*5,970	*5,970	(18.1)
6.0 m (19.7 ft)	kg						*3,700	*3,700			*2,430	*2,430	6.79
	lb						*8,160	*8,160			*5,360	*5,360	(22.3)
4.5 m (14.8 ft)	kg						*4,020	3,780	*2,570	*2,570	*2,340	*2,340	7.56
	lb						*8,860	8,330	*5,670	*5,670	*5,160	*5,160	(24.8)
3.0 m (9.8 ft)	kg		*7,930	*7,930	*5,540	*5,540	*4,580	3,630	*3,790	2,570	*2,380	2,330	7.97
	lb		*17,480	*17,480	*12,210	*12,210	*10,100	8,000	*8,360	5,670	*5,250	5,140	(26.2)
1.5 m (4.9 ft)	kg		*6,760	*6,760	*6,920	5,180	*5,230	3,450	3,740	2,490	*2,530	2,220	8.09
	lb		*14,900	*14,900	*15,260	11,420	*11,530	7,610	8,250	5,490	*5,580	4,890	(26.5)
0.0m (0.0ft)	kg		*6,160	*6,160	*7,830	4,910	5,080	3,310	3,670	2,430	*2,820	2,260	7.91
	lb		*13,580	*13,580	*17,260	10,820	11,200	7,300	8,090	5,360	*6,220	4,980	(25.9)
-1.5 m (-4.9 ft)	kg	*4,790	*4,790	*8,770	*8,770	7,740	4,800	5,000	3,240		*3,360	2,440	7.42
	lb	*10,560	*10,560	*19,330	*19,330	17,060	10,580	11,020	7,140		*7,410	5,380	(24.3)
-3.0 m (-9.8 ft)	kg	*8,080	*8,080	*10,910	8,920	*7,450	4,820	5,020	3,260		4,440	2,910	6.55
	lb	*17,810	*17,810	*24,050	19,670	*16,420	10,630	11,070	7,190		9,790	6,420	(21.5)
-4.5 m (-14.8 ft)	kg			*8,260	*8,260	*5,640	4,980				*4,650	4,200	5.11
	lb			*18,210	*18,210	*12,430	10,980				*10,250	9,260	(16.8)

5.10 m (16' 9") boom, 3.10 m (10' 2") arm equipped with 3,250kg counter weight, 600mm(24") Triple grouser shoe and with Dozer down.

Lift-point height (m/ft)	Lift-point radius										At max. reach		
	1.5 m (4.9 ft)		3.0 m (9.8 ft)		4.5 m (14.8 ft)		6.0 m (19.7 ft)		7.5 m (24.6 ft)		Capacity		Reach
													m (ft)
7.5 m (24.6 ft)	kg										*2,710	*2,710	5.51
	lb										*5,970	*5,970	(18.1)
6.0 m (19.7 ft)	kg						*3,700	*3,700			*2,430	*2,430	6.79
	lb						*8,160	*8,160			*5,360	*5,360	(22.3)
4.5 m (14.8 ft)	kg						*4,020	3,780	*2,570	*2,570	*2,340	*2,340	7.56
	lb						*8,860	8,330	*5,670	*5,670	*5,160	*5,160	(24.8)
3.0 m (9.8 ft)	kg		*7,930	*7,930	*5,540	*5,540	*4,580	3,630	*3,790	2,570	*2,380	2,330	7.97
	lb		*17,480	*17,480	*12,210	*12,210	*10,100	8,000	*8,360	5,670	*5,250	5,140	(26.2)
1.5 m (4.9 ft)	kg		*6,760	*6,760	*6,920	5,180	*5,230	3,450	3,740	2,490	*2,530	2,220	8.09
	lb		*14,900	*14,900	*15,260	11,420	*11,530	7,610	8,250	5,490	*5,580	4,890	(26.5)
0.0m (0.0ft)	kg		*6,160	*6,160	*7,830	4,910	*5,230	3,310	*4,580	2,430	*2,820	2,260	7.91
	lb		*13,580	*13,580	*17,260	10,820	*12,630	7,300	*10,100	5,360	*6,220	4,980	(25.9)
-1.5 m (-4.9 ft)	kg	*4,790	*4,790	*8,770	*8,770	7,800	4,800	5,860	3,240		*3,360	2,440	7.42
	lb	*10,560	*10,560	*19,330	*19,330	*17,700	10,580	*12,920	7,140		*7,410	5,380	(24.3)
-3.0 m (-9.8 ft)	kg	*8,080	*8,080	*10,910	8,920	*7,450	4,820	5,360	3,260		4,510	2,910	6.55
	lb	*17,810	*17,810	*24,050	19,670	*16,420	10,630	*11,820	7,190		*9,940	6,420	(21.5)
-4.5 m (-14.8 ft)	kg			*8,260	*8,260	*5,640	4,980				*4,650	4,200	5.11
	lb			*18,210	*18,210	*12,430	10,980				*10,250	9,260	(16.8)

1 | Lifting capacity are based on ISO 10567.

2 | Lifting capacity of HX Series does not exceed 75% of tipping load with the machine on firm, level ground or 87% of full hydraulic capacity.

3 | The Lift-point is bucket pivot mounting pin on the arm(without bucket mass).

4 | (*) indicates load limited by hydraulic capacity.

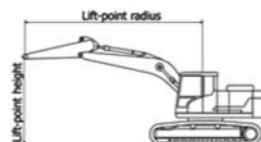

HX160A L 2-PIECE BOOM

5.10 m (16' 9") boom, 2.20 m (7' 3") arm equipped with 3,250kg counter weight, 600mm(24") Triple grouser shoe and without Dozer.

Lift-point height (m/ft)	Lift-point radius										At max. reach		
	3.0 m (9.8 ft)		4.5 m (14.8 ft)		6.0 m (19.7 ft)		7.5 m (24.6 ft)		Capacity		Reach		
											m (ft)		
7.5 m (24.6 ft)	kg										*4,850	*4,850	4.43
	lb										*10,690	*10,690	(14.5)
6.0 m (19.7 ft)	kg										*3,970	3,580	5.95
	lb										*8,750	7,890	(19.5)
4.5 m (14.8 ft)	kg			*4,510	*4,510						*3,670	2,840	6.82
	lb			*9,940	*9,940						*8,090	6,260	(22.4)
3.0 m (9.8 ft)	kg			*5,110	*5,110	*4,560	3,530				*3,620	2,520	7.28
	lb			*11,270	*11,270	*10,050	7,780				*7,980	5,560	(23.9)
1.5 m (4.9 ft)	kg			*6,280	5,140	*5,010	3,390				*3,750	2,410	7.40
	lb			*13,850	11,330	*11,050	7,470				*8,270	5,310	(24.3)
0.0m (0.0ft)	kg			*7,440	4,810	5,280	3,250				*4,000	2,470	7.20
	lb			*16,400	10,600	11,640	7,170				*8,820	5,450	(23.6)
-1.5 m (-4.9 ft)	kg			7,980	4,640	5,170	3,150				4,470	2,760	6.66
	lb			17,590	10,230	11,400	6,940				9,850	6,080	(21.9)
-3.0 m (-9.8 ft)	kg			*8,360	*8,360	*7,890	4,620	5,160	3,130				
	lb			*18,430	*18,430	*17,390	10,190	11,380	6,900				

5.10 m (16' 9") boom, 2.20 m (7' 3") arm equipped with 3,250kg counter weight, 600mm(24") Triple grouser shoe and with Dozer up.

Lift-point height (m/ft)	Lift-point radius										At max. reach		
	3.0 m (9.8 ft)		4.5 m (14.8 ft)		6.0 m (19.7 ft)		7.5 m (24.6 ft)		Capacity		Reach		
											m (ft)		
7.5 m (24.6 ft)	kg												











LIFTING CAPACITY

 Rating over-front  Rating over-side or 360 degree











 Rating over-front  Rating over-side or 360 degree

HX160A L 2-PIECE BOOM











5.10 m (16' 9") boom, 2.60 m (8' 6") arm equipped with 3,250kg counter weight, 600mm(24") Triple grouser shoe and without Dozer.

Lift-point height (m/ft)	Lift-point radius								At max. reach		
	3.0 m (9.8 ft)		4.5 m (14.8 ft)		6.0 m (19.7 ft)		7.5 m (24.6 ft)		Capacity		Reach
											m (ft)
7.5 m (24.6 ft)	kg		*4,310	*4,310					*3,570	*3,570	5.00
	lb		*9,500	*9,500					*7,870	*7,870	(16.4)
6.0 m (19.7 ft)	kg				*4,130	3,610			*3,050	*3,050	6.39
	lb				*9,110	7,960			*6,720	*6,720	(21.0)
4.5 m (14.8 ft)	kg		*4,680	*4,680	*4,250	3,560			*2,870	*2,870	7.20
	lb		*10,320	*10,320	*9,370	7,850			*6,330	*5,780	(23.6)
3.0 m (9.8 ft)	kg		*5,870	5,210	*4,750	3,410	*3,660	2,410	*2,850	2,340	7.63
	lb		*12,940	11,490	*10,470	7,520	*8,070	5,310	*6,280	5,160	(25.0)
1.5 m (4.9 ft)	kg		*7,130	4,850	5,290	3,250	3,800	2,350	*2,970	2,240	7.75
	lb		*15,720	10,690	11,660	7,170	8,380	5,180	*6,550	4,940	(25.4)
0.0m (0.0ft)	kg		*7,880	4,630	5,160	3,210	3,750	2,310	*3,250	2,280	7.56
	lb		*17,370	10,210	11,380	6,900	8,270	5,090	*7,170	5,030	(24.8)
-1.5 m (-4.9 ft)	kg	*8,290	*8,290	7,900	4,570	5,110	3,090		*3,800	2,510	7.05
	lb	*18,280	*18,280	17,420	10,080	11,270	6,810		*8,380	5,530	(23.1)
-3.0 m (-9.8 ft)	kg			*7,200	4,640						
	lb			*15,870	10,230						

5.10 m (16' 9") boom, 2.60 m (8' 6") arm equipped with 3,250kg counter weight, 600mm(24") Triple grouser shoe and with Dozer up.

Lift-point height (m/ft)	Lift-point radius								At max. reach		
	3.0 m (9.8 ft)		4.5 m (14.8 ft)		6.0 m (19.7 ft)		7.5 m (24.6 ft)		Capacity		Reach
											m (ft)
7.5 m (24.6 ft)	kg		*4,310	*4,310					*3,570	*3,570	5.00
	lb		*9,500	*9,500					*7,870	*7,870	(16.4)
6.0 m (19.7 ft)	kg				*4,130	3,800			*3,050	*3,050	6.39
	lb				*9,110	8,380			*6,720	*6,720	(21.0)
4.5 m (14.8 ft)	kg		*4,680	*4,680	*4,250	3,750			*2,870	2,770	7.20
	lb		*10,320	*10,320	*9,370	8,270			*6,330	6,110	(23.6)
3.0 m (9.8 ft)	kg		*5,870	5,480	*4,750	3,600	*3,660	2,550	*2,850	2,480	7.63
	lb		*12,940	12,080	*10,470	7,940	*8,070	5,620	*6,280	5,470	(25.0)
1.5 m (4.9 ft)	kg		*7,130	5,110	5,250	3,430	3,760	2,490	*2,970	2,370	7.75
	lb		*15,720	11,270	11,570	7,560	8,290	5,490	*6,550	5,220	(25.4)
0.0m (0.0ft)	kg		*7,880	4,900	5,110	3,320	3,720	2,450	*3,250	2,420	7.56
	lb		*17,370	10,800	11,270	7,320	8,200	5,400	*7,170	5,340	(24.8)
-1.5 m (-4.9 ft)	kg	*8,290	*8,290	7,830	4,830	5,070	3,270		*3,800	2,670	7.05
	lb	*18,280	*18,280	17,260	10,650	11,180	7,210		*8,380	5,890	(23.1)
-3.0 m (-9.8 ft)	kg			*7,200	4,900						
	lb			*15,870	10,800						

5.10 m (16' 9") boom, 2.60 m (8' 6") arm equipped with 3,250kg counter weight, 600mm(24") Triple grouser shoe and with Dozer down.

Lift-point height (m/ft)	Lift-point radius								At max. reach		
	3.0 m (9.8 ft)		4.5 m (14.8 ft)		6.0 m (19.7 ft)		7.5 m (24.6 ft)		Capacity		Reach
											m (ft)
7.5 m (24.6 ft)	kg		*4,310	*4,310					*3,570	*3,570	5.00
	lb		*9,500	*9,500					*7,870	*7,870	(16.4)
6.0 m (19.7 ft)	kg				*4,130	3,800			*3,050	*3,050	6.39
	lb				*9,110	8,380			*6,720	*6,720	(21.0)
4.5 m (14.8 ft)	kg		*4,680	*4,680	*4,250	3,750			*2,870	2,770	7.20
	lb		*10,320	*10,320	*9,370	8,270			*6,330	6,110	(23.6)
3.0 m (9.8 ft)	kg		*5,870	5,480	*4,750	3,600	*3,660	2,550	*2,850	2,480	7.63
	lb		*12,940	12,080	*10,470	7,940	*8,070	5,620	*6,280	5,470	(25.0)
1.5 m (4.9 ft)	kg		*7,130	5,110	*5,330	3,430	*4,480	2,490	*2,970	2,370	7.75
	lb		*15,720	11,270	*11,750	7,560	*9,880	5,490	*6,550	5,220	(25.4)
0.0m (0.0ft)	kg		*7,880	4,900	*5,760	3,320	*3,840	2,450	*3,250	2,420	7.56
	lb		*17,370	10,800	*12,700	7,320	*8,470	5,400	*7,170	5,340	(24.8)
-1.5 m (-4.9 ft)	kg	*8,290	*8,290	*7,950	4,830	*5,810	3,270		*3,800	2,670	7.05
	lb	*18,280	*18,280	*17,530	10,650	*12,810	7,210		*8,380	5,890	(23.1)
-3.0 m (-9.8 ft)	kg			*7,200	4,900						
	lb			*15,870	10,800						

1 | Lifting capacity are based on ISO 10567.

2 | Lifting capacity of HX Series does not exceed 75% of tipping load with the machine on firm, level ground or 87% of full hydraulic capacity.





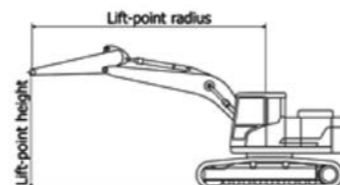





3 | The Lift-point is bucket pivot mounting pin on the arm(without bucket mass).

4 | (*) indicates load limited by hydraulic capacity.













HX180A L MONO BOOM

5.10 m (16' 9") boom, 2.20 m (7' 3") arm equipped with 2,900kg counter weight, 600mm(24") Triple grouser shoe and without Dozer.

Lift-point height (m/ft)	Lift-point radius								At max. reach		
	1.5 m (4.9 ft)		3.0 m (9.8 ft)		4.5 m (14.8 ft)		6.0 m (19.7 ft)		Capacity		Reach
											m (ft)
6.0 m (19.7 ft)	kg								*3,850	*3,850	5.86
	lb								*8,490	*8,490	(19.2)
4.5 m (14.8 ft)	kg				*5,320	*5,320	*4,750	3,880	*3,630	3,210	6.74
	lb				*11,730	*11,730	*10,470	8,550	*8,000	7,080	(22.1)
3.0 m (9.8 ft)	kg				*6,540	5,720	*5,200	3,750	*3,650	2,840	7.20
	lb				*14,420	12,610	*11,460	8,270	*8,050	6,260	(23.6)
1.5 m (4.9 ft)	kg				*7,690	5,400	5,530	3,610	*3,850	2,720	7.33
	lb				*16,950	11,900	12,190	7,960	*8,490	6,000	(24.0)
0.0m (0.0ft)	kg				*8,180	5,230	5,420	3,510	4,230	2,780	7.13
	lb				*18,030	11,530	11,950	7,740	9,330	6,130	(23.4)
-1.5 m (-4.9 ft)	kg				*9,400	*9,400	*7,910	5,200	5,390	3,490	6.58
	lb				*20,720	*20,720	*17,440	11,460	11,880	7,690	(21.6)
-3.0 m (-9.8 ft)	kg				*9,400	*9,400	*6,720	5,290			
	lb				*20,720	*20,720	*14,820	11,660	*10,980	8,690	(18.3)

5.10 m (16' 9") boom, 2.20 m (7' 3") arm equipped with 2,900kg counter weight, 600mm(24") Triple grouser shoe and with Dozer up.

Lift-point height (m/ft)	Lift-point radius								At max. reach		
	1.5m (4.9ft)		3.0m (9.8ft)		4.5m (14.8ft)		6.0m (19.7ft)		Capacity		Reach
											m (ft)
6.0m (19.7ft)	kg								*3,850	*3,850	5.86
	lb								*8,490	*8,490	(19.2)
4.5m (14.8ft)	kg				*5,320	*5,320	*4,750	4,090	*3,630	3,390	6.74
	lb				*11,730	*11,730	*10,470	9,020	*8,000	7,470	(22.1)
3.0m (9.8ft)	kg				*6,540	6,030	*5,200	3,960	*3,650	3,010	7.20
	lb				*14,420	13,290	*11,460	8,730	*8,050	6,640	(23.6)
1.5m (4.9ft)	kg				*7,690	5,700	5,470	3,820	*3,850	2,880	7.33
	lb				*16,950	12,570	12,060	8,420	*8,490	6,350	(24.0)
0.0m (0.0ft)	kg				*8,180	5,530	5,370	3,720	4,190	2,950	7.13
	lb				*18,030	12,190	11,840	8,200	9,240	6,500	(23.4)
-1.5m (-4.9ft)	kg				*9,400	*9,400	*7,910	5,500	5,340	3,700	6.58
	lb				*20,7						

LIFTING CAPACITY

Rating over-front Rating over-side or 360 degree

Rating over-front Rating over-side or 360 degree

HX180A L MONO BOOM

5.10 m (16' 9") boom, 2.20 m (7' 3") arm equipped with 3,250kg counter weight, 600mm(24") Triple grouser shoe and without Dozer.

Lift-point height (m/ft)	Lift-point radius								At max. reach		
	1.5m (4.9ft)		3.0m (9.8ft)		4.5m (14.8ft)		6.0m (19.7ft)		Capacity	Reach	
6.0 m (19.7 ft)	kg								*3,850	*3,850	5.86
	lb								*8,490	*8,490	(19.2)
4.5 m (14.8 ft)	kg			*5,320	*5,320	*4,750	4,070		*3,630	3,370	6.74
	lb			*11,730	*11,730	*10,470	8,970		*8,000	7,430	(22.1)
3.0 m (9.8 ft)	kg			*6,540	6,010	*5,200	3,950		*3,650	2,990	7.20
	lb			*14,420	13,250	*11,460	8,710		*8,050	6,590	(23.6)
1.5 m (4.9 ft)	kg			*7,690	5,680	*5,710	3,800		*3,850	2,870	7.33
	lb			*16,950	12,520	*12,590	8,380		*8,490	6,330	(24.0)
0.0m (0.0ft)	kg			*8,180	5,510	5,660	3,710		*4,310	2,940	7.13
	lb			*18,030	12,150	12,480	8,180		*9,500	6,480	(23.4)
-1.5 m (-4.9 ft)	kg		*9,400	*9,400	*7,910	5,480	5,640	3,680	4,950	3,270	6.58
	lb		*20,720	*20,720	*17,440	12,080	12,430	8,110	10,910	7,210	(21.6)
-3.0 m (-9.8 ft)	kg		*9,400	*9,400	*6,720	5,570			*4,980	4,160	5.58
	lb		*20,720	*20,720	*14,820	12,280			*10,980	9,170	(18.3)

5.10 m (16' 9") boom, 2.20 m (7' 3") arm equipped with 3,250kg counter weight, 600mm(24") Triple grouser shoe and with Dozer up.

Lift-point height (m/ft)	Lift-point radius								At max. reach		
	1.5m (4.9ft)		3.0m (9.8ft)		4.5m (14.8ft)		6.0m (19.7ft)		Capacity	Reach	
6.0 m (19.7 ft)	kg								*3,850	*3,850	5.86
	lb								*8,490	*8,490	(19.2)
4.5 m (14.8 ft)	kg			*5,320	*5,320	*4,750	4,280		*3,630	3,560	6.74
	lb			*11,730	*11,730	*10,470	9,440		*8,000	7,850	(22.1)
3.0 m (9.8 ft)	kg			*6,540	6,310	*5,200	4,150		*3,650	3,160	7.20
	lb			*14,420	13,910	*11,460	9,150		*8,050	6,970	(23.6)
1.5 m (4.9 ft)	kg			*7,690	5,990	*5,710	4,010		*3,850	3,030	7.33
	lb			*16,950	13,210	*12,590	8,840		*8,490	6,680	(24.0)
0.0m (0.0ft)	kg			*8,180	5,810	5,610	3,910		*4,310	3,110	7.13
	lb			*18,030	12,810	12,370	8,620		*9,500	6,860	(23.4)
-1.5 m (-4.9 ft)	kg		*9,400	*9,400	*7,910	5,780	5,590	3,890	4,910	3,460	6.58
	lb		*20,720	*20,720	*17,440	12,740	12,320	8,580	10,820	7,630	(21.6)
-3.0 m (-9.8 ft)	kg		*9,400	*9,400	*6,720	5,870			*4,980	4,390	5.58
	lb		*20,720	*20,720	*14,820	12,940			*10,980	9,680	(18.3)

5.10 m (16' 9") boom, 2.20 m (7' 3") arm equipped with 3,250kg counter weight, 600mm(24") Triple grouser shoe and with Dozer down.

Lift-point height (m/ft)	Lift-point radius								At max. reach		
	1.5m (4.9ft)		3.0m (9.8ft)		4.5m (14.8ft)		6.0m (19.7ft)		Capacity	Reach	
6.0 m (19.7 ft)	kg								*3,850	*3,850	5.86
	lb								*8,490	*8,490	(19.2)
4.5 m (14.8 ft)	kg			*5,320	*5,320	*4,750	4,280		*3,630	3,560	6.74
	lb			*11,730	*11,730	*10,470	9,440		*8,000	7,850	(22.1)
3.0 m (9.8 ft)	kg			*6,540	6,310	*5,200	4,150		*3,650	3,160	7.20
	lb			*14,420	13,910	*11,460	9,150		*8,050	6,970	(23.6)
1.5 m (4.9 ft)	kg			*7,690	5,990	*5,710	4,010		*3,850	3,030	7.33
	lb			*16,950	13,210	*12,590	8,840		*8,490	6,680	(24.0)
0.0m (0.0ft)	kg			*8,180	5,810	*5,980	3,910		*4,310	3,110	7.13
	lb			*18,030	12,810	*13,180	8,620		*9,500	6,860	(23.4)
-1.5 m (-4.9 ft)	kg		*9,400	*9,400	*7,910	5,780	*5,770	3,890	*5,030	3,460	6.58
	lb		*20,720	*20,720	*17,440	12,740	*12,720	8,580	*11,090	7,630	(21.6)
-3.0 m (-9.8 ft)	kg		*9,400	*9,400	*6,720	5,870			*4,980	4,390	5.58
	lb		*20,720	*20,720	*14,820	12,940			*10,980	9,680	(18.3)

1 | Lifting capacity are based on ISO 10567.

2 | Lifting capacity of HX Series does not exceed 75% of tipping load with the machine on firm, level ground or 87% of full hydraulic capacity.

3 | The Lift-point is bucket pivot mounting pin on the arm(without bucket mass).

4 | (*) indicates load limited by hydraulic capacity.

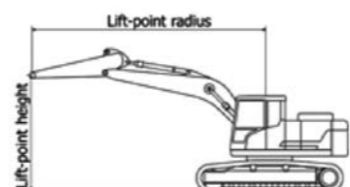

HX180A L MONO BOOM

5.10 m (16' 9") boom, 2.60 m (8' 6") arm equipped with 2,900kg counter weight, 600mm(24") Triple grouser shoe and without Dozer.

Lift-point height (m/ft)	Lift-point radius										At max. reach			
	1.5 m (4.9 ft)		3.0 m (9.8 ft)		4.5 m (14.8 ft)		6.0 m (19.7 ft)		7.5 m (24.6 ft)		Capacity	Reach		
7.5 m (24.6 ft)	kg										*3,410	*3,410	4.85	
	lb										*7,520	*7,520	(15.9)	
6.0 m (19.7 ft)	kg							*3,840	*3,840		*2,970	*2,970	6.27	
	lb							*8,470	*8,470		*6,550	*6,550	(20.6)	
4.5 m (14.8 ft)	kg					*4,870	*4,870	*4,430	3,910		*2,850	*2,850	7.10	
	lb					*10,740	*10,740	*9,770	8,620		*6,280	*6,280	(23.3)	
3.0 m (9.8 ft)	kg			*9,370	*9,370	*6,120	5,790	*4,940	3,770	*3,110	2,670	*2,880	2,650	7.54
	lb			*20,660	*20,660	*13,490	12,760	*10,890	8,310	*6,860	5,890	*6,350	5,840	(24.7)
1.5 m (4.9 ft)	kg					*7,380	5,430	*5,520	3,610	3,960	2,610	*3,060	2,530	7.66
	lb					*16,270	11,970	*12,170	7,960	8,730	5,750	*6,750	5,580	(25.1)
0.0m (0.0ft)	kg			*5,290	*5,290	*8,070	5,220	5,400	3,490			*3,420	2,580	7.47
	lb			*11,660	*11,660	*17,790	11,510	11,900	7,690			*7,540	5,690	(24.5)
-1.5 m (-4.9 ft)	kg	*5,090	*5,090	*9,190	*9,190	*8,010	5,150	5,350	3,450			*4,130	2,840	6.95
	lb	*11,220	*11,220	*20,260	*20,260	*17,660	11,350	11,790	7,610			*9,110	6,260	(22.8)
-3.0 m (-9.8 ft)	kg	*9,360	*9,360	*10,170	9,930	*7,120	5,210	*4,910	3,510			*4,890	3,500	6.01
	lb	*20,640	*20,640	*22,420	21,890	*15,700	11,490	*10,820	7,740			*10,780	7,720	(19.7)
-4.5 m (-14.8 ft)	kg			*6,860	*6,860							*4,560	*4,560	4.39
	lb			*15,120	*15,120							*10,050	*10,050	(14.4)

5.10 m (16' 9") boom, 2.60 m (8' 6") arm equipped with 2,900kg counter weight, 600mm(24") Triple grouser shoe and with Dozer up.

Lift-point height (m/ft)	Lift-point radius										At max. reach			
	1.5 m (4.9 ft)		3.0 m (9.8 ft)		4.5 m (14.8 ft)		6.0 m (19.7 ft)		7.5 m (24.6 ft)		Capacity	Reach		
7.5 m (24.6 ft)	kg										*3,410	*3,410	4.85	
	lb										*7,520	*7,520	(15.9)	
6.0 m (19.7 ft)	kg							*3,840	*3,840		*2,970	*2,970	6.27	
	lb							*8,470	*8,470		*6,550	*6,550	(20.6)	
4.5 m (14.8 ft)	kg					*4,870	*4,870	*4,430	4,120		*2,850	*2,850	7.10	
	lb					*10,740	*10,740	*9,770	9,080		*6,280	*6,280	(23.3)	
3.0 m (9.8 ft)	kg			*9,370	*9,370	*6,120	6,100	*4,940	3,980	*3,110	2,830	*2,880	2,810	7.54
	lb			*20,660	*20,660	*13,490	13,450	*10,890	8,770	*6,860	6,240	*6,350	6,190	(24.7)
1.5 m (4.9 ft)	kg					*7,380	5,740	5,480	3,820	3,920	2,770	*3,060	2,690	7.66
	lb					*16,270	12,650	12,080	8,420	8,640	6,110	*6,750	5,930	(25.1)
0.0m (0.0ft)	kg			*5,290	*5,290	*8,070	5,520	5,350	3,700			*3,420	2,740	7.47
	lb			*11,660	*11,660	*17,790	12,170	11,790	8,160			*7,540	6,040	(24.5)
-1.5 m (-4.9 ft)	kg	*5,090	*5,090	*9,190	*9,190	*8,010	5,460	5,300	3,660			*4,130	3,020	6.95
	lb	*11,220	*11,220	*20,260	*20,260	*17,660	12,040	11,680	8,070			*9,110	6,660	(22.8)
-3.0 m (-9.8 ft)	kg	*9,360	*9,360	*10,170	*10,170	*7,120	5,510	*4,910	3,720			*4,890	3,710	6.01
	lb	*20,640	*20,640	*22,420	*22,420	*15,700	12,150	*10,820	8					

LIFTING CAPACITY

Rating over-front Rating over-side or 360 degree

HX180A L MONO BOOM

5.10 m (16' 9") boom, 2.60 m (8' 6") arm equipped with 3,250kg counter weight, 600mm(24") Triple grouser shoe and without Dozer.

Lift-point height (m/ft)	Lift-point radius										At max. reach		
	1.5 m (4.9 ft)		3.0 m (9.8 ft)		4.5 m (14.8 ft)		6.0 m (19.7 ft)		7.5 m (24.6 ft)		Capacity	Reach	
											kg	lb	
7.5 m (24.6 ft)											*3,410	*3,410	4.85
											*7,520	*7,520	(15.9)
6.0 m (19.7 ft)							*3,840	*3,840			*2,970	*2,970	6.27
							*8,470	*8,470			*6,550	*6,550	(20.6)
4.5 m (14.8 ft)							*4,870	*4,870			*2,850	*2,850	7.10
							*10,740	*10,740			*6,280	*6,280	(23.3)
3.0 m (9.8 ft)							*9,370	*9,370			*2,880	*2,790	7.54
							*20,660	*20,660			*6,350	*6,150	(24.7)
1.5 m (4.9 ft)							*7,380	5,720			*3,060	2,680	7.66
							*16,270	12,610			*6,750	5,910	(25.1)
0.0m (0.0ft)							*5,290	*5,290			*3,420	2,730	7.47
							*11,660	*11,660			*7,540	6,020	(24.5)
-1.5 m (-4.9 ft)							*9,190	*9,190			*4,130	3,000	6.95
							*11,220	*11,220			*9,110	6,610	(22.8)
-3.0 m (-9.8 ft)							*9,360	*9,360			*4,890	3,700	6.01
							*20,640	*20,640			*10,780	8,160	(19.7)
-4.5 m (-14.8 ft)							*6,860	*6,860			*4,560	*4,560	4.39
							*15,120	*15,120			*10,050	*10,050	(14.4)

5.10 m (16' 9") boom, 2.60 m (8' 6") arm equipped with 3,250kg counter weight, 600mm(24") Triple grouser shoe and with Dozer up.

Lift-point height (m/ft)	Lift-point radius										At max. reach		
	1.5 m (4.9 ft)		3.0 m (9.8 ft)		4.5 m (14.8 ft)		6.0 m (19.7 ft)		7.5 m (24.6 ft)		Capacity	Reach	
											kg	lb	
7.5 m (24.6 ft)											*3,410	*3,410	4.85
											*7,520	*7,520	(15.9)
6.0 m (19.7 ft)							*3,840	*3,840			*2,970	*2,970	6.27
							*8,470	*8,470			*6,550	*6,550	(20.6)
4.5 m (14.8 ft)							*4,870	*4,870			*2,850	*2,850	7.10
							*10,740	*10,740			*6,280	*6,280	(23.3)
3.0 m (9.8 ft)							*9,370	*9,370			*2,880	*2,880	7.54
							*20,660	*20,660			*6,350	*6,350	(24.7)
1.5 m (4.9 ft)							*7,380	6,020			*3,060	2,830	7.66
							*16,270	13,270			*6,750	6,240	(25.1)
0.0m (0.0ft)							*5,290	*5,290			*3,420	2,890	7.47
							*11,660	*11,660			*7,540	6,370	(24.5)
-1.5 m (-4.9 ft)							*9,190	*9,190			*4,130	3,180	6.95
							*11,220	*11,220			*9,110	7,010	(22.8)
-3.0 m (-9.8 ft)							*9,360	*9,360			*4,890	3,900	6.01
							*20,640	*20,640			*10,780	8,600	(19.7)
-4.5 m (-14.8 ft)							*6,860	*6,860			*4,560	*4,560	4.39
							*15,120	*15,120			*10,050	*10,050	(14.4)

5.10 m (16' 9") boom, 2.60 m (8' 6") arm equipped with 3,250kg counter weight, 600mm(24") Triple grouser shoe and with Dozer down.

Lift-point height (m/ft)	Lift-point radius										At max. reach		
	1.5 m (4.9 ft)		3.0 m (9.8 ft)		4.5 m (14.8 ft)		6.0 m (19.7 ft)		7.5 m (24.6 ft)		Capacity	Reach	
											kg	lb	
7.5 m (24.6 ft)											*3,410	*3,410	4.85
											*7,520	*7,520	(15.9)
6.0 m (19.7 ft)							*3,840	*3,840			*2,970	*2,970	6.27
							*8,470	*8,470			*6,550	*6,550	(20.6)
4.5 m (14.8 ft)							*4,870	*4,870			*2,850	*2,850	7.10
							*10,740	*10,740			*6,280	*6,280	(23.3)
3.0 m (9.8 ft)							*9,370	*9,370			*2,880	*2,880	7.54
							*20,660	*20,660			*6,350	*6,350	(24.7)
1.5 m (4.9 ft)							*7,380	6,020			*3,060	2,830	7.66
							*16,270	13,270			*6,750	6,240	(25.1)
0.0m (0.0ft)							*5,290	*5,290			*3,420	2,890	7.47
							*11,660	*11,660			*7,540	6,370	(24.5)
-1.5 m (-4.9 ft)							*9,190	*9,190			*4,130	3,180	6.95
							*11,220	*11,220			*9,110	7,010	(22.8)
-3.0 m (-9.8 ft)							*9,360	*9,360			*4,890	3,900	6.01
							*20,640	*20,640			*10,780	8,600	(19.7)
-4.5 m (-14.8 ft)							*6,860	*6,860			*4,560	*4,560	4.39
							*15,120	*15,120			*10,050	*10,050	(14.4)

1 | Lifting capacity are based on ISO 10567.

2 | Lifting capacity of HX Series does not exceed 75% of tipping load with the machine on firm, level ground or 87% of full hydraulic capacity.

3 | The Lift-point is bucket pivot mounting pin on the arm (without bucket mass).

4 | (*) indicates load limited by hydraulic capacity.

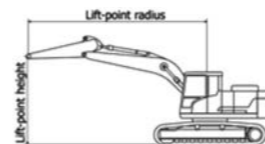

Rating over-front Rating over-side or 360 degree

HX180A L MONO BOOM

5.10 m (16' 9") boom, 3.10 m (10' 2") arm equipped with 2,900kg counter weight, 600mm(24") Triple grouser shoe and without Dozer.

Lift-point height (m/ft)	Lift-point radius										At max. reach										
	1.5m (4.9 ft)		3.0m (9.8 ft)		4.5m (14.8 ft)		6.0m (19.7 ft)		7.5m (24.6 ft)		Capacity	Reach									
											kg	lb									
7.5 m (24.6 ft)											*2,710	*2,710	5.51								
											*5,970	*5,970	(18.1)								
6.0 m (19.7 ft)											*2,430	*2,430	6.79								
											*5,360	*5,360	(22.3)								
4.5 m (14.8 ft)											*2,340	*2,340	7.56								
											*8,860	8,710	(24.8)								
3.0 m (9.8 ft)											*4,020	3,950	*2,570	*2,570	*2,340	*2,340	7.56				
											*8,860	8,710	*5,670	*5,670	*5,160	*5,160	(24.8)				
1.5 m (4.9 ft)											*7,930	*7,930	*5,540	*5,540	*4,580	3,790	*3,790	2,670	*2,380	*2,380	7.97
											*17,480	*17,480	*12,210	*12,210	*10,100	8,360	*8,360	5,890	*5,250	*5,250	(26.2)
0.0m (0.0ft)											*6,160	*6,160	*7,830	5,470	*5,230	3,610	3,940	2,590	*2,530	2,310	8.09
											*14,900	*14,900	*15,260	12,060	*11,530	7,960	8,690	5,710	*5,580	5,090	(26.5)
-1.5 m (-4.9 ft)											*4,790	*4,790	*8,770	*8,770	*8,030	5,080	5,290	3,390	*3,360	2,540	7.42
											*10,560	*10,560	*19,330	*19,330	*17,700	11,200	11,660	7,470	*7,410	5,600	(24.3)
-3.0 m (-9.8 ft)											*8,080	*8,080	*10,910	9,730	*7,450	5,100	5,310	3,410	*4,510	3,040	6.55
											*17,810	*17,810	*24,050	21,450	*16,420	11,240	11,710	7,520	*9,940	6,700	(21.5)
-4.5 m (-14.8 ft)											*8,260	*8,260	*5,640	5,260					*4,650	4,410	5.11
											*18,210	*18,210	*12,430	11,600					*10,250	9,720	(16.8)

5.10 m (16' 9") boom, 3.10 m (10' 2") arm equipped with 2,900kg counter weight, 600mm(24") Triple grouser shoe and with Dozer up.

Lift-point height (m/ft)	Lift-point radius										At max. reach										
	1.5 m (4.9 ft)		3.0 m (9.8 ft)		4.5 m (14.8 ft)		6.0 m (19.7 ft)		7.5 m (24.6 ft)		Capacity	Reach									
											kg	lb									
7.5 m (24.6 ft)											*2,710	*2,710	5.51								
											*5,970	*5,970	(18.1)								
6.0 m (19.7 ft)											*2,430	*2,430	6.79								
											*5,360	*5,360	(22.3)								
4.5 m (14.8 ft)											*2,340	*2,340	7.56								
											*8,860	*8,860	*5,670	*5,670	*5,160	*5,160	(24.8)				
3.0 m (9.8 ft)											*4,580	4,000	*3,790	2,830	*2,380	*2,380	7.97				
											*17,480	*17,480	*12,210	*12,210	*10,100	8,820	*8,360	6,240	*5,250	*5,250	(26.2)
1.5 m (4.9 ft)											*6,760	*6,760	*6,920	5,780	*5,230	3,820	3,900	2,750	*2,530	2,460	8.09
											*14,900	*14,900	*15,260	12,740	*11,530</						

LIFTING CAPACITY

Rating over-front Rating over-side or 360 degree

Rating over-front Rating over-side or 360 degree

HX180A L MONO BOOM

5.10 m (16' 9") boom, 3.10 m (10' 2") arm equipped with 3,250kg counter weight, 600mm(24") Triple grouser shoe and without Dozer.

Lift-point height (m/ft)	Lift-point radius										At max. reach		
	1.5m (4.9 ft)		3.0m (9.8 ft)		4.5m (14.8 ft)		6.0m (19.7 ft)		7.5m (24.6 ft)		Capacity		Reach
													m (ft)
7.5 m (24.6 ft)	kg										*2,710	*2,710	5.51
	lb										*5,970	*5,970	(18.1)
6.0 m (19.7 ft)	kg						*3,700	*3,700			*2,430	*2,430	6.79
	lb						*8,160	*8,160			*5,360	*5,360	(22.3)
4.5 m (14.8 ft)	kg						*4,020	*4,020	*2,570	*2,570	*2,340	*2,340	7.56
	lb						*8,860	*8,860	*5,670	*5,670	*5,160	*5,160	(24.8)
3.0 m (9.8 ft)	kg		*7,930	*7,930	*5,540	*5,540	*4,580	3,980	*3,790	2,820	*2,380	*2,380	7.97
	lb		*17,480	*17,480	*12,210	*12,210	*10,100	8,770	*8,360	6,220	*5,250	*5,250	(26.2)
1.5 m (4.9 ft)	kg		*6,760	*6,760	*6,920	5,750	*5,230	3,800	4,120	2,740	*2,530	2,440	8.09
	lb		*14,900	*14,900	*15,260	12,680	*11,530	8,380	9,080	6,040	*5,580	5,380	(26.5)
0.0m (0.0ft)	kg		*6,160	*6,160	*7,830	5,480	5,620	3,660	4,050	2,670	*2,820	2,480	7.91
	lb		*13,580	*13,580	*17,260	12,080	12,390	8,070	8,930	5,890	*6,220	5,470	(25.9)
-1.5 m (-4.9 ft)	kg	*4,790	*4,790	*8,770	*8,770	*8,030	5,360	5,540	3,580		*3,360	2,690	7.42
	lb	*10,560	*10,560	*19,330	*19,330	*17,700	11,820	12,210	7,890		*7,410	5,930	(24.3)
-3.0 m (-9.8 ft)	kg	*8,080	*8,080	*10,910	10,250	*7,450	5,380	*5,360	3,600		*4,510	3,210	6.55
	lb	*17,810	*17,810	*24,050	22,600	*16,420	11,860	*11,820	7,940		*9,940	7,080	(21.5)
-4.5 m (-14.8 ft)	kg		*8,260	*8,260	*5,640	5,550					*4,650	*4,650	5.11
	lb		*18,210	*18,210	*12,430	12,240					*10,250	*10,250	(16.8)

5.10 m (16' 9") boom, 3.10 m (10' 2") arm equipped with 3,250kg counter weight, 600mm(24") Triple grouser shoe and with Dozer up.

Lift-point height (m/ft)	Lift-point radius										At max. reach		
	1.5 m (4.9 ft)		3.0 m (9.8 ft)		4.5 m (14.8 ft)		6.0 m (19.7 ft)		7.5 m (24.6 ft)		Capacity		Reach
													m (ft)
7.5 m (24.6 ft)	kg										*2,710	*2,710	5.51
	lb										*5,970	*5,970	(18.1)
6.0 m (19.7 ft)	kg						*3,700	*3,700			*2,430	*2,430	6.79
	lb						*8,160	*8,160			*5,360	*5,360	(22.3)
4.5 m (14.8 ft)	kg						*4,020	*4,020	*2,570	*2,570	*2,340	*2,340	7.56
	lb						*8,860	*8,860	*5,670	*5,670	*5,160	*5,160	(24.8)
3.0 m (9.8 ft)	kg		*7,930	*7,930	*5,540	*5,540	*4,580	4,190	*3,790	2,980	*2,380	*2,380	7.97
	lb		*17,480	*17,480	*12,210	*12,210	*10,100	9,240	*8,360	6,570	*5,250	*5,250	(26.2)
1.5 m (4.9 ft)	kg		*6,760	*6,760	*6,920	6,060	*5,230	4,010	4,080	2,900	*2,530	*2,530	8.09
	lb		*14,900	*14,900	*15,260	13,360	*11,530	8,840	8,990	6,390	*5,580	*5,580	(26.5)
0.0m (0.0ft)	kg		*6,160	*6,160	*7,830	5,780	5,570	3,870	4,010	2,830	*2,820	2,630	7.91
	lb		*13,580	*13,580	*17,260	12,740	12,280	8,530	8,840	6,240	*6,220	5,800	(25.9)
-1.5 m (-4.9 ft)	kg	*4,790	*4,790	*8,770	*8,770	*8,030	5,670	5,480	3,790		*3,360	2,850	7.42
	lb	*10,560	*10,560	*19,330	*19,330	*17,700	12,500	12,080	8,360		*7,410	6,280	(24.3)
-3.0 m (-9.8 ft)	kg	*8,080	*8,080	*10,910	10,810	*7,450	5,680	*5,360	3,810		*4,510	3,400	6.55
	lb	*17,810	*17,810	*24,050	23,830	*16,420	12,520	*11,820	8,400		*9,940	7,500	(21.5)
-4.5 m (-14.8 ft)	kg		*8,260	*8,260	*5,640	*5,640					*4,650	*4,650	5.11
	lb		*18,210	*18,210	*12,430	*12,430					*10,250	*10,250	(16.8)

5.10 m (16' 9") boom, 3.10 m (10' 2") arm equipped with 3,250kg counter weight, 600mm(24") Triple grouser shoe and with Dozer down.

Lift-point height (m/ft)	Lift-point radius										At max. reach		
	1.5 m (4.9 ft)		3.0 m (9.8 ft)		4.5 m (14.8 ft)		6.0 m (19.7 ft)		7.5 m (24.6 ft)		Capacity		Reach
													m (ft)
7.5 m (24.6 ft)	kg										*2,710	*2,710	5.51
	lb										*5,970	*5,970	(18.1)
6.0 m (19.7 ft)	kg						*3,700	*3,700			*2,430	*2,430	6.79
	lb						*8,160	*8,160			*5,360	*5,360	(22.3)
4.5 m (14.8 ft)	kg						*4,020	*4,020	*2,570	*2,570	*2,340	*2,340	7.56
	lb						*8,860	*8,860	*5,670	*5,670	*5,160	*5,160	(24.8)
3.0 m (9.8 ft)	kg		*7,930	*7,930	*5,540	*5,540	*4,580	4,190	*3,790	2,980	*2,380	*2,380	7.97
	lb		*17,480	*17,480	*12,210	*12,210	*10,100	9,240	*8,360	6,570	*5,250	*5,250	(26.2)
1.5 m (4.9 ft)	kg		*6,760	*6,760	*6,920	6,060	*5,230	4,010	*4,390	2,900	*2,530	*2,530	8.09
	lb		*14,900	*14,900	*15,260	13,360	*11,530	8,840	*9,680	6,390	*5,580	*5,580	(26.5)
0.0m (0.0ft)	kg		*6,160	*6,160	*7,830	5,780	*5,730	3,870	*4,580	2,830	*2,820	2,630	7.91
	lb		*13,580	*13,580	*17,260	12,740	*12,630	8,530	*10,100	6,240	*6,220	5,800	(25.9)
-1.5 m (-4.9 ft)	kg	*4,790	*4,790	*8,770	*8,770	*8,030	5,670	*5,860	3,790		*3,360	2,850	7.42
	lb	*10,560	*10,560	*19,330	*19,330	*17,700	12,500	*12,920	8,360		*7,410	6,280	(24.3)
-3.0 m (-9.8 ft)	kg	*8,080	*8,080	*10,910	10,810	*7,450	5,680	*5,360	3,810		*4,510	3,400	6.55
	lb	*17,810	*17,810	*24,050	23,830	*16,420	12,520	*11,820	8,400		*9,940	7,500	(21.5)
-4.5 m (-14.8 ft)	kg		*8,260	*8,260	*5,640	*5,640					*4,650	*4,650	5.11
	lb		*18,210	*18,210	*12,430	*12,430					*10,250	*10,250	(16.8)

1 | Lifting capacity are based on ISO 10567.

2 | Lifting capacity of HX Series does not exceed 75% of tipping load with the machine on firm, level ground or 87% of full hydraulic capacity.

3 | The Lift-point is bucket pivot mounting pin on the arm(without bucket mass).

4 | (*) indicates load limited by hydraulic capacity.

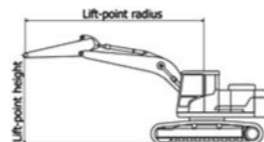

HX180A L 2-PIECE BOOM

5.10 m (16' 9") boom, 2.20 m (7' 3") arm equipped with 3,250kg counter weight, 600mm(24") Triple grouser shoe and without Dozer.

Lift-point height (m/ft)	Lift-point radius										At max. reach		
	3.0m (9.8ft)		4.5m (14.8ft)		6.0m (19.7ft)		7.5m (24.6ft)		Capacity		Reach		
											m (ft)		
7.5m (24.6ft)	kg										*4,850	*4,850	4.43
	lb										*10,690	*10,690	(14.5)
6.0m (19.7ft)	kg										*3,970	*3,970	5.95
	lb										*8,750	*8,750	(19.5)
4.5m (14.8ft)	kg			*4,510	*4,510						*3,670	*3,670	6.82
	lb			*9,940	*9,940						*8,090	*8,090	(22.4)
3.0m (9.8ft)	kg			*5,110	*5,110	*4,560	4,070				*3,620	2,930	7.28
	lb			*11,270	*11,270	*10,050	8,970				*7,980	6,460	(23.9)
1.5m (4.9ft)	kg			*6,280	6,010	*5,010	3,940				*3,750	2,810	7.40
	lb			*13,850	13,250	*11,050	8,690				*8,270	6,190	(24.3)
0.0m (0.0ft)	kg			*7,440	5,660	*5,530	3,790				*4,090	2,890	7.20
	lb			*16,400	12,480	*12,190	8,360				*9,020	6,370	(23.6)
-1.5m (-4.9ft)	kg	*8,360	*8,360	*7,890	5,460	5,660	3,670				*4,780	3,220	6.66
	lb	*18,430	*18,430	*17,390	12,040	12,480	8,090				*10,540	7,100	(21.9)

5.10 m (16' 9") boom, 2.20 m (7' 3") arm equipped with 3,250kg counter weight, 600mm(24") Triple grouser shoe and with Dozer up.

Lift-point height (m/ft)	Lift-point radius										At max. reach		
	3.0m (9.8ft)		4.5m (14.8ft)		6.0m (19.7ft)		7.5m (24.6ft)		Capacity		Reach		
											m (ft)		
7.5m (24.6ft)	kg										*4,850	*4,850	4.43
	lb										*10,690	*10,690	(14.5)
6.0m (19.7ft)	kg												

LIFTING CAPACITY

Rating over-front Rating over-side or 360 degree

HX180A L 2-PIECE BOOM

5.10 m (16' 9") boom, 2.60 m (8' 6") arm equipped with 3,250kg counter weight, 600mm(24") Triple grouser shoe and without Dozer.

Lift-point height (m/ft)	Lift-point radius								At max. reach		
	3.0m (9.8ft)		4.5m (14.8ft)		6.0m (19.7ft)		7.5m (24.6ft)		Capacity	Reach	
7.5m 24.6ft	kg		*4,310	*4,310					*3,570	*3,570	5.00
	lb		*9,500	*9,500					*7,870	*7,870	(16.4)
6.0m 19.7ft	kg				*4,130	*4,130			*3,050	*3,050	6.39
	lb				*9,110	*9,110			*6,720	*6,720	(21.0)
4.5m 14.8ft	kg		*4,680	*4,680	*4,250	4,110			*2,870	*2,870	7.20
	lb		*10,320	*10,320	*9,370	9,060			*6,330	*6,330	(23.6)
3.0m 9.8ft	kg		*5,870	*5,870	*4,750	3,960	*3,660	2,810	*2,850	*2,720	7.63
	lb		*12,940	*12,940	*10,470	8,730	*8,070	6,190	*6,280	6,000	(25.0)
1.5m 4.9ft	kg		*7,130	5,700	*5,330	3,790	4,150	2,750	*2,970	2,610	7.75
	lb		*15,720	12,570	*11,750	8,360	9,150	6,060	*6,550	5,750	(25.4)
0.0m 0.0ft	kg		*7,880	5,470	5,660	3,670	*3,840	2,700	*3,250	2,670	7.56
	lb		*17,370	12,060	12,480	8,090	*8,470	5,950	*7,170	5,890	(24.8)
-1.5m -4.9ft	kg	*8,290	*8,290	*7,950	5,410	5,610	3,620		*3,800	2,940	7.05
	lb	*18,280	*18,280	*17,530	11,930	12,370	7,980		*8,380	6,480	(23.1)
-3.0m -9.8ft	kg		*7,200	5,480							
	lb		*15,870	12,080							

5.10 m (16' 9") boom, 2.60 m (8' 6") arm equipped with 3,250kg counter weight, 600mm(24") Triple grouser shoe and with Dozer up.

Lift-point height (m/ft)	Lift-point radius								At max. reach		
	3.0m (9.8ft)		4.5m (14.8ft)		6.0m (19.7ft)		7.5m (24.6ft)		Capacity	Reach	
7.5m 24.6ft	kg		*4,310	*4,310					*3,570	*3,570	5.00
	lb		*9,500	*9,500					*7,870	*7,870	(16.4)
6.0m 19.7ft	kg				*4,130	*4,130			*3,050	*3,050	6.39
	lb				*9,110	*9,110			*6,720	*6,720	(21.0)
4.5m 14.8ft	kg		*4,680	*4,680	*4,250	*4,250			*2,870	*2,870	7.20
	lb		*10,320	*10,320	*9,370	*9,370			*6,330	*6,330	(23.6)
3.0m 9.8ft	kg		*5,870	*5,870	*4,750	4,170	*3,660	2,970	*2,850	*2,850	7.63
	lb		*12,940	*12,940	*10,470	9,190	*8,070	6,550	*6,280	*6,280	(25.0)
1.5m 4.9ft	kg		*7,130	6,000	*5,330	4,000	4,110	2,900	*2,970	2,770	7.75
	lb		*15,720	13,230	*11,750	8,820	9,060	6,390	*6,550	6,110	(25.4)
0.0m 0.0ft	kg		*7,880	5,780	5,610	3,880	*3,840	2,860	*3,250	2,830	7.56
	lb		*17,370	12,740	12,370	8,550	*8,470	6,310	*7,170	6,240	(24.8)
-1.5m -4.9ft	kg	*8,290	*8,290	*7,950	5,710	5,560	3,830		*3,800	3,110	7.05
	lb	*18,280	*18,280	*17,530	12,590	12,260	8,440		*8,380	6,860	(23.1)
-3.0m -9.8ft	kg		*7,200	5,780							
	lb		*15,870	12,740							

5.10 m (16' 9") boom, 2.60 m (8' 6") arm equipped with 3,250kg counter weight, 600mm(24") Triple grouser shoe and with Dozer down.

Lift-point height (m/ft)	Lift-point radius								At max. reach		
	3.0m (9.8ft)		4.5m (14.8ft)		6.0m (19.7ft)		7.5m (24.6ft)		Capacity	Reach	
7.5m 24.6ft	kg		*4,310	*4,310					*3,570	*3,570	5.00
	lb		*9,500	*9,500					*7,870	*7,870	(16.4)
6.0m 19.7ft	kg				*4,130	*4,130			*3,050	*3,050	6.39
	lb				*9,110	*9,110			*6,720	*6,720	(21.0)
4.5m 14.8ft	kg		*4,680	*4,680	*4,250	*4,250			*2,870	*2,870	7.20
	lb		*10,320	*10,320	*9,370	*9,370			*6,330	*6,330	(23.6)
3.0m 9.8ft	kg		*5,870	*5,870	*4,750	4,170	*3,660	2,970	*2,850	*2,850	7.63
	lb		*12,940	*12,940	*10,470	9,190	*8,070	6,550	*6,280	*6,280	(25.0)
1.5m 4.9ft	kg		*7,130	6,000	*5,330	4,000	*4,480	2,900	*2,970	2,770	7.75
	lb		*15,720	13,230	*11,750	8,820	*9,880	6,390	*6,550	6,110	(25.4)
0.0m 0.0ft	kg		*7,880	5,780	*5,760	3,880	*3,840	2,860	*3,250	2,830	7.56
	lb		*17,370	12,740	*12,700	8,550	*8,470	6,310	*7,170	6,240	(24.8)
-1.5m -4.9ft	kg	*8,290	*8,290	*7,950	5,710	*5,810	3,830		*3,800	3,110	7.05
	lb	*18,280	*18,280	*17,530	12,590	*12,810	8,440		*8,380	6,860	(23.1)
-3.0m -9.8ft	kg		*7,200	5,780							
	lb		*15,870	12,740							

- Lifting capacity are based on ISO 10567.
- Lifting capacity of HX Series does not exceed 75% of tipping load with the machine on firm, level ground or 87% of full hydraulic capacity.
- The Lift-point is bucket pivot mounting pin on the arm(without bucket mass).
- (*) indicates load limited by hydraulic capacity.

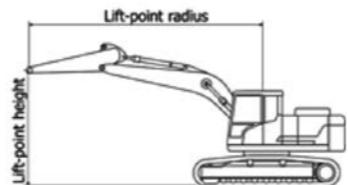

BUCKET SELECTION GUIDE & DIGGING FORCE

BUCKETS

All buckets are welded with high-strength steel.

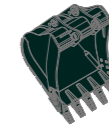

0.73 (0.96)
0.85 (1.11)

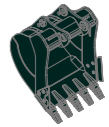

0.88 (1.15)
0.96 (1.26)

SAE Heaped
m³ (yd³)

Type	Capacity m³ (yd³)		Width mm (in)		Weight kg (lb)	Tooth EA	Recommendation mm (ft-in)				
	SAE Heaped	CECE Heaped	Without Sidecutters	With Sidecutters			5,100 (16' 9") boom			5,100 (16' 9") 2pcs boom	
							2,200 (7' 3") Arm	2,600 (8' 6") Arm	3,100 (10' 2") Arm	2,200 (7' 3") Arm	2,600 (8' 6") Arm
HX160A L	Counterweight						2,600kg		3,250kg		
	*0.73 (0.95)	0.67 (0.88)	914 (36.0")	946 (37.2")	617 (1,360)	5	●	●	●	●	
	*0.85 (1.11)	0.76 (0.99)	1,067 (42.0")	1,098 (43.1")	669 (1,470)	5	●	■	x	●	
	0.88 (1.15)	0.77 (1.01)	1,200 (47.2")	1,270 (50.0")	662 (1,460)	5	●	■	x	●	
	Counterweight						3,250kg		3,250kg		
	*0.73 (0.96)	0.67 (0.88)	914 (36.0")	946 (37.2")	617 (1,360)	5	●	●	●	●	
*0.85 (1.11)	0.76 (0.99)	1,067 (42.0")	1,098 (43.1")	669 (1,470)	5	●	●	x	●		
0.88 (1.15)	0.77 (1.01)	1,200 (47.2")	1,270 (50.0")	662 (1,460)	5	●	●	x	●		
0.96 (1.26)	0.84 (1.10)	1,350 (53.1")	1,420 (55.9")	726 (1,600)	6	■	■	x	x		
HX180A L	Counterweight						2,900kg		3,250kg		
	*0.73 (0.96)	0.67 (0.88)	914 (36.0")	946 (37.2")	617 (1,360)	5	●	●	●	●	
	*0.85 (1.11)	0.76 (0.99)	1,067 (42.0")	1,098 (43.1")	669 (1,470)	5	●	●	●	●	
	0.88 (1.15)	0.77 (1.01)	1,200 (47.2")	1,270 (50.0")	662 (1,460)	5	●	●	●	●	
	0.96 (1.26)	0.84 (1.10)	1,350 (53.1")	1,420 (55.9")	726 (1,600)	6	●	●	■	●	
	Counterweight						3,250kg		3,250kg		
*0.73 (0.96)	0.67 (0.88)	914 (36.0")	946 (37.2")	617 (1,360)	5	●	●	●	●		
*0.85 (1.11)	0.76 (0.99)	1,067 (42.0")	1,098 (43.1")	669 (1,470)	5	●	●	●	●		
0.88 (1.15)	0.77 (1.01)	1,200 (47.2")	1,270 (50.0")	662 (1,460)	5	●	●	●	●		
0.96 (1.26)	0.84 (1.10)	1,350 (53.1")	1,420 (55.9")	726 (1,600)	6	●	●	●	●		

* Hammerless tooth type bucket

- : Applicable for materials with density of 2,100 kgf/m³ (3,500 lbf/yd³) or less
- : Applicable for materials with density of 1,800 kgf/m³ (3,000 lbf/yd³) or less
- ▲ : Applicable for materials with density of 1,500 kgf/m³ (2,500 lbf/yd³) or less
- ▲ : Applicable for materials with density of 1,200 kgf/m³ (2,000 lbf/yd³) or less
- x : Not Recommended

BUCKET SELECTION GUIDE & DIGGING FORCE

ATTACHMENT

Booms and arms are welded with a low-stress, full-box section design.
5.1 m mono boom, 2-piece boom and 2.2 m, 2.6 m, 3.1 m arms are available.

DIGGING FORCE

Boom	Length	mm (ft-in)	5,100 (16' 9") Mono Boom			5,100 (16' 9") 2-Piece Boom		Remark
	Weight	kg (lb)	1,277 (2,810)			1,785 (3,940)		
Arm	Length	mm (ft-in)	2,200 (7' 3")	2,600 (8' 6")	3,100 (10' 2")	2,200 (7' 3")	2,600 (8' 6")	Remark
	Weight	kg (lb)	807 (1,780)	860 (1,900)	888 (1,960)	807 (1,780)	860 (1,900)	
Bucket Digging Force	SAE	kN	108.0 [117.0]	108.0 [117.0]	108.0 [117.0]	108.0 [117.0]	108.0 [117.0]	[] : Power Boost
		kgf	10,987 [11,930]	10,004 [11,950]	11,006 [11,950]	10,987 [11,930]	11,004 [11,950]	
		lbf	24,222 [26,301]	24,259 [26,345]	24,264 [26,345]	24,222 [26,301]	24,259 [26,345]	
	ISO	kN	126.0 [137.0]	126.0 [137.0]	126.0 [137.0]	126.0 [137.0]	126.0 [137.0]	
		kgf	12,872 [13,980]	12,892 [14,000]	12,894 [14,000]	12,872 [13,980]	12,892 [14,000]	
		lbf	28,379 [30,821]	28,421 [30,865]	28,427 [30,865]	28,379 [30,821]	28,421 [30,865]	
Arm Crowd Force	SAE	kN	87.0 [95.0]	77.0 [84.0]	69.0 [75.0]	87.0 [95.0]	77.0 [84.0]	
		kgf	8,889 [9,650]	7,879 [8,550]	7,035 [7,640]	8,889 [9,650]	7,879 [8,550]	
		lbf	19,596 [21,275]	17,370 [18,850]	15,510 [16,843]	19,596 [21,275]	17,370 [18,850]	
	ISO	kN	92.0 [99.0]	81.0 [88.0]	72.0 [78.0]	92.0 [99.0]	81.0 [88.0]	
		kgf	9,339 [10,140]	8,237 [8,940]	7,314 [7,940]	9,339 [10,140]	8,237 [8,940]	
		lbf	20,590 [22,355]	18,158 [19,709]	16,124 [17,505]	20,590 [22,355]	18,158 [19,709]	

Note : Boom weight includes arm cylinder, piping, and pin
Arm weight includes bucket cylinder, linkage, and pin

STANDARD / OPTION

ENGINE	STD	OPT
Cummins B4.5		
Engine Auto Idle	●	
Engine Auto Shutdown Control	●	
Emergency Engine Stop Switch	●	
HYDRAULIC SYSTEM	STD	OPT
Intelligent Power Control (IPC) Upgrade		
3-Power Mode, 2-Work Mode, User Mode	●	
Variable Power Control	●	
Pump Flow Control	●	
Attachment Mode Flow Control		●
Hyundai Bio Hydraulic oil (HBHO)		●
CAB & INTERIOR	STD	OPT
ISO Standard cabin		
Rise-Up Type Windshield Wiper	●	
Radio / USB Player	●	
Handsfree Mobile Phone System with USB	●	
12V Power Outlet (24V DC to 12V DC converter)	●	
Electric Horn	●	
All-Weather Steel Cab with 360° Visibility	●	
Safety glass - Tempered glass	●	
Safety glass - Tempered glass with front laminated glass		●
Sliding Fold-In Front Window	●	
Sliding Side Window (LH)	●	
Lockable Door	●	
Hot & Cool Box	●	
Storage Compartment	●	
Ashtray & Cigar Lighter		●
Transparent Cabin Roof-Cover	●	
Sun Visor	●	
Door And Cab Locks, One Key	●	
Mechanical Suspension Seat With Heater	●	
Pilot-Operated Slidable Joystick	●	
Console Box Height Adjust System	●	
Automatic climate control		
Air Conditioner & Heater	●	
Defroster	●	
Starting Aid (Air Grid Heater) for Cold Weather	●	
Centralized monitoring		
8" LCD Display	●	
Engine Speed or Trip Meter / Accel.	●	
Engine Coolant Temperature Gauge	●	
Max Power	●	
Low Speed / High Speed	●	
Auto Idle	●	
Overload warning with alarm		●
Check Engine	●	
Air Cleaner Clogging	●	
Indicators	●	
ECO Gauges	●	
Fuel Level Gauge	●	
Hyd. Oil Temperature Gauge	●	
Fuel Warmer	●	
Warnings	●	
Communication Error	●	
Low Battery	●	
Clock	●	
Cabin Lights	●	
Cabin Front Window Rain Guard		●
Cabin Roof-Steel Cover		●
Seat		
Adjustable Air Suspension Seat With Heater		●
Cabin FOG (ISO 10262) Level 2		
FOG (Falling Object Protective Structure) · ISO 10262 Level 2		●
Cabin ROPS		
ROPS (Roll Over Protective Structures) · ISO 12117-2	●	

SAFETY	STD	OPT
Lifting Mode	●	
Auto Safety Lock	●	
Seatbelt Warning Alarm	●	
Battery Master Switch	●	
Rear View Camera		●
Rear & Mirror View Camera		●
AAVM (Advanced Around View Monitoring)		●
Four Front Working Lights (2 Boom Mounted, 2 Front Frame Mounted)	●	
Travel Alarm	●	
Rear Work Lamp		●
Beacon Lamp		●
Automatic Swing Brake	●	
Boom Holding System	●	
Arm Holding System	●	
Safety Lock Valve		●
For Boom Cylinder With Overload Warning Device		●
Safety Lock Valve For Arm Cylinder		●
Swing Lock System		●
Three Outside Rearview Mirror	●	
Front Guard - Wire Net		●
ATTACHMENT	STD	OPT
Booms		
5.10 m, 16' 9" Mono	●	
5.10 m, 16' 9" 2-Piece		●
Arms		
2.2 m, 7' 3"		●
2.6 m, 8' 6"	●	
3.1 m, 10' 2"		●
OTHER	STD	OPT
Fuel Pre-Filter	●	
Fuel Warmer	●	
Pre-Cleaner		●
Coolant Heater		●
Self-Diagnostics System	●	
Hi MATE (Remote Management System)		●
Batteries (2 × 12 V × 100 AH)	●	
Fuel Filler Pump (35 lpm)		●
Single-Acting Piping Kit (Breaker, Etc.)		●
Double-Acting Piping Kit (Clamshell, Etc.)		●
Proportional Auxiliary Hydraulic System		●
2 Way Proportional RCV & Pedal Control Selection		●
Rotating Piping Kit		●
Bucket Line Dividing Kit		●
Air Compressor		●
Quick Coupler Piping		●
Quick Coupler		●
One Pedal Straight Travel System		●
Accumulator For Lowering Work Equipment	●	
Pattern Change Valve (2 Patterns)		●
Fine (Cushion/Free) Swing Control		●
Tool Kit		●
UNDERCARRIAGE	STD	OPT
Lower Frame Under Cover	●	
Track Shoes		
Triple Grousers Shoes (500 mm, 20")		●
Triple Grousers Shoes (600 mm, 24")	●	
Triple Grousers Shoe (700 mm, 28")		●
Triple Grousers Shoe (800 mm, 32") - HX180AL Only		●
Track Guard	●	

* Standard and optional equipment may vary. Contact your Hyundai dealer for more information. The machine may vary according to International standards.
* The photos may include attachments and optional equipment that are not available in your area.
* Materials and specifications are subject to change without advance notice.
* All imperial measurements rounded off to the nearest pound or inch.