

### STANDARD EQUIPMENT

ISO Standard cabin
All-weather steel cab with 3600 visibility
Safety glass windows
Rise-up type windshield wiper
Sliding fold-in front window
Sliding side window(LH)
Lockable door
Hot & cool box
Storage compartment & Ashtray
Transparent cabin roof-cover
Radio / USB player
Handsfree mobile phone system with USB
12 volt power outlet (24V DC to 12V DC converter)
Sun visor
Computer aided power optimization (New CAPO) system
3-power mode, 2-work mode, user mode
Auto deceleration & one-touch deceleration system
Auto warm-up system
Auto overheat prevention system
Automatic climate control
Air conditioner & heater
Defroster
Self-diagnostics system
Starting Aid (air grid heater) for cold weather
Centralized monitoring
LCD display
Engine speed or Trip meter/Accel.
Clock
Gauges
Fuel level gauge
Engine coolant temperature gauge
Hyd. oil temperature gauge
Warnings
Check engine
Communication error
Low battery
Air cleaner clogging
Indicators
Max power
Low speed/High speed
Fuel warmer
Auto idle
Door and cab locks, one key
Three outside rearview mirrors
Mechanical suspension seat with heater
Pilot-operated slidable joystick
Console box height adjust system
Four front working lights
Electric horn
Batteries (2 x 12V x 100 AH)
Battery master switch
Removable clean-out dust net for cooler
Automatic swing brake
Removable reservoir tank
Fuel pre-filter with fuel warmer
Boom holding system
Arm holding system
Track shoes (500mm, 20")
Track rail guard
Accumulator for lowering work equipment
Electric transducer
Lower frame under cover (Normal)
Viscous fan clutch

### OPTIONAL EQUIPMENT

Fuel filler pump (50L / min)
Beacon lamp
Safety lock valve for boom cylinder with overload warning device
Safety lock valve for arm cylinder
Single-acting piping kit (breaker, etc.)
Double-acting piping kit (clamshell, etc.)
Quick coupler
Travel alarm
Booms
5.65 m, 18' 6" Mono
5.65 m, 18' 6" Hydraulic Adjustable
Arms
2.0 m, 6' 7"
2.4 m, 7' 10"
2.92 m, 9' 7"
Climate control
Air conditioner only
Heater only
Cabin FOPS/FOG (ISO/DIS 10262 Level II)
FOPS (Falling Object Protective Structure)
FOG (Falling Object Guard)
Cabin ROPS (ISO 12117-2)
ROPS (Roll Over Protective Structure)
Cabin-guard front
Wire net
Fine net
Cabin roof-steel cover
Cabin lights
Cabin front window rain guard
Track shoes
Triple grousers shoe (600 mm, 24" )
Lower frame under cover (Additional)
Pre-heating system, coolant
Tool kit
Operator suit
Rearview camera
Seat
Adjustable air suspension seat
Adjustable air suspension seat with heater
Mechanical suspension seat
Pattern change valve (2 patterns)
Hi-mate (Remote Management System)
Air compressor
Precleaner

\* Standard and optional equipment may vary. Contact your Hyundai dealer for more information. The machine may vary according to International standards.  
 \* The photos may include attachments and optional equipment that are not available in your area.  
 \* Materials and specifications are subject to change without advance notice.  
 \* All imperial measurements rounded off to the nearest pound or inch.



Head Office(Sales Office)  
 14F, GLOBAL R&D CENTER, 477 BUNDANG SUSEO-RO, BUNDANG-GU, SEONGNAM-SI, GYEONGGI-DO, 13553, KOREA

# Robex 210 NLC-9

With Tier 3 Engine installed



\* Photo may include optional equipment.

PLEASE CONTACT

# Pride at Work

Hyundai construction equipment strives to build state-of-the-art earthmoving equipment to give every operator maximum performance, more precision, versatile machine preferences, and proven quality. Take pride in your work with Hyundai!



# Robex 210NLC-9

## Machine Walk-Around

### Engine Technology

Proven / reliable, fuel efficient Hyundai Tier3 HE6.7 engine  
Electronically controlled for optimum fuel to air ratio and clean, efficient combustion  
Low noise / Auto engine overheat feature / Anti-restart feature

### Hydraulic System Improvements

New patented hydraulic control for improved controllability / Improved control valve design for added efficiency and smoother operation / New auto boom and swing priority system for optimum speed / New auto power boost feature for additional power when needed / Improved arm-in and boom-down flow regeneration system for added speed and efficiency

### Pump Compartment

Industry-leading, powerful, reliable Kawasaki designed, variable volume in-line axial piston pumps  
New compact solenoid block equipped with 4 solenoid valves, 1 EPPR valve, 1 check valve accumulator and line filter controls  
2 speed travel, power boost, boom priority, arm-in regeneration, safety lock

### Enhanced Operator Cab

#### Improved Visibility

Enlarged cab with improved visibility / See-through upper skylight for visibility and ventilation  
Larger right-side glass - now one piece, for better right visibility  
Safety glass windows on all sides - less expensive than (polycarbonate) and won't scratch or fade  
Closeable sunshade for operator convenience / Reduced front window seam for improved operator view

#### Improved Cab Construction

New steel tube construction for added operator safety, protection and durability  
New window open/close mechanism designed with cable and spring lift assist and single latch release

#### Improved Suspension Seat / Console Assembly

Ergonomic joysticks with auxiliary control buttons for attachment use. Now with new sleek styling  
Adjustable heated suspension seat, control console and arm rests

#### Advanced 7" Color Cluster

New Color LCD Display with easy-to-read digital gauges for hydraulic oil temperature, water temperature, and fuel. A simplified design makes adjustment and diagnostics easier. Also, new enhanced features such as rear-view camera are integrated into monitor.  
3 power modes : (P) Power, (S) Standard, (E) Economy, 2 work modes : Dig & Attachment, (U) User mode for operator preference  
Enhanced self-diagnostic features with GPS download capability  
One pump flow or two pump flow for optional attachment now selectable through the cluster / New anti-theft system with password capability  
Boom speed and arm regeneration are selectable through the monitor.  
Auto power boost is now available - selectable (on/off) through the monitor.  
Powerful air conditioning and heat with auto climate control, 20% more heat and air output than 7A series!  
RMS (Remote Management System) works through GPS/satellite technology to ultimately provide better customer service and support.

### Undercarriage

Sealed track chain (urethane seals) / Standard track rail guard / Comfortable bolt-on steps  
Large upper roller cut-outs for debris clean-out / Tapered side frames for debris clean-out / Grease-type track tensioner

# Preference

Operating a 9 series is unique to every operator. Operators can fully customize their work environment and operating preferences to fit their individual needs.



\*Photo may include optional equipment.

## Operator Comfort

In 9 series cabin you can easily adjust the seat, console and armrest settings to best suit your preferred comfort level. Seat and console position and height can be set together and independent from each other. Other preference settings that add to overall operator comfort include the full automatic high capacity airconditioning system and the Radio / USB player.



## Reduced Stress

Work is stressful enough. Your work environment should be stress free. Hyundai's 9 series provides improved cab amenities, additional space and a comfortable seat to minimize stress to the operator. A powerful climate control system provides the operator with optimum air temperature. An advanced audio system with USB player, AM / FM stereo, plus remotely located controls is perfect for listening to music favorites. Operators can even talk on the phone with the hands-free cell phone feature.



## Operator - Friendly Cluster

The advanced new cluster with 7 inch wide color LCD screen and toggle switch allows the operator to select his personal machine preferences. Power and work mode selection, self diagnostics, optional rearview camera, maintenance check lists, start-up machine security, and video functions were integrated into the cluster to make the machine more versatile and the operator more productive.

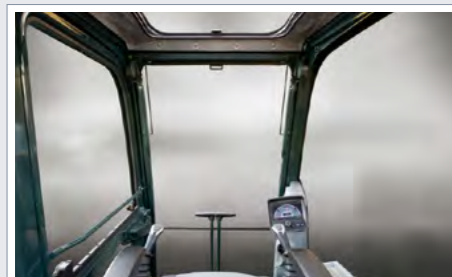

## Wide Cabin with Excellent Visibility

The newly designed cabin was conceived for more space, a wider field of view and operator comfort. Special attention was given to a clear, open and convenient interior with plenty of visibility on the machine surroundings and the job at hand. This well balanced combination of precision aspects put the operator in the perfect position to work safely and securely.

# Precision

Innovative hydraulic system technologies make the 9 series excavator fast, smooth and easy to control.



## Computer Aided Power

The engine horsepower and hydraulic horsepower together in unison through the advanced CAPO(Computer Aided Power Optimization) system, provide the precise flow needed for the job at hand. Operators can set their own preferences for boom or swing priority, power mode selection and optional work tools at the touch of a button.

The CAPO system also provides complete self diagnostic features and digital gauges for important information like hydraulic oil temperature, water temperature and fuel level. This system interfaces with multiple sensors placed throughout the hydraulic system as well as the electronically controlled engine to provide the optimum level of engine power and hydraulic flow.

### Power Mode

P (Power Max) mode maximizes machine speed and power for mass production. S (Standard) mode provides a reduced, fixed rpm for optimum performance and improved fuel economy. For maximum fuel savings and improved control, E (Economy) mode provides precise flow and engine power based on load demand. Three unique power modes provide the operator with custom power, speed and fuel economy.

### Work Mode

The work mode allows the operator to select single flow attachments like a hydraulic breaker or bi-directional flow attachments like a crusher. Flow settings unique to each attachment can be programmed from within the cluster.

### User Mode

Some jobs require more precise machine settings. Using the versatile U (User) mode, the operator can customize engine speed, pump output, idle speed and other machine settings for the job at hand.

## Improved Hydraulic System



To achieve optimum precision, Hyundai redesigned the hydraulic system to provide the operator with super fine touch and improved controllability. Improved pump flow control reduces flow when controls are not being used to minimize fuel consumption.

Improved spool valves in the control valve are engineered to provide more precise flow to each function with less effort.

Improved hydraulic valves, precision-designed variable volume piston pumps, fine-touch pilot controls, and enhanced travel functions make any operator running a 9series look like a smooth operator. Newly improved

features include arm-in and boom-down flow regeneration, improved control valve technology and innovative auto boom and swing priority for optimal performance in any application.

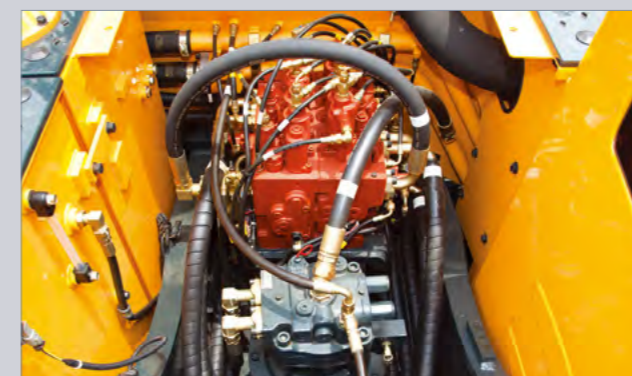

## Auto Boom & Swing Priority

This smart function automatically and continuously looks the ideal hydraulic flow balance for the boom and swing motions of the machine. The advanced CAPO system monitors the hydraulic system and adjusts its settings to maximize performance and productivity.

\*Photo may include optional equipment.

# Performance

9 series is designed for maximum performance to keep the operator working productively.



\*Photo may include optional equipment.

## Track Rail Guard & Adjusters

Durable track rail guards keep track links in place. Track adjustment is made easy with standard grease cylinder track adjusters and shock absorbing springs.

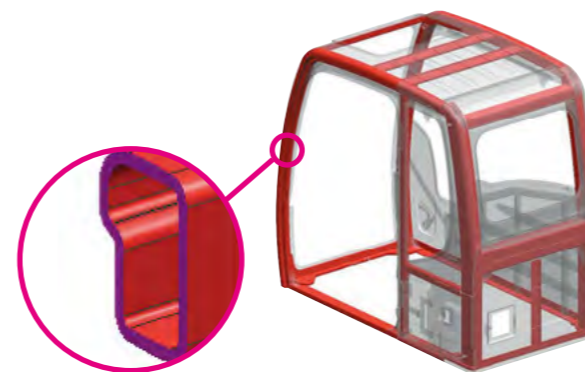

## Structure Strength

The 9 series cabin structure has been fitted with stronger but slimmer tubing for more safety and improved visibility. Lowstress, high strength steel is integrally welded to form a stronger, more durable upper and lower frame. Structural integrity was tested by way of FEM (Finite Elements Method) analysis and long-term durability tests. The optional ROPS(Roll Over Protective Structure) cab can be equipped to enhance operator safety.

## Hyundai HE6.7 Engine

The Tier III, six cylinder, 4 cycle, turbo-charged, charge air cooled, Hyundai HE6.7 engine provides maximum power, reliability, optimum fuel economy, and reduced emissions. Electronically controlled fuel injection and diagnostic capabilities add to the engines efficiency and serviceability.

## Heavy-duty strength

Everyone who's ever worked on construction equipment knows, there is no substitute for power and durability. The HE6.7 handles the toughest loads and the roughest work conditions. At the same time, it delivers better fuel economy, has better cold starting capability and is up to 50% quieter in operation. Plus, the heavy-duty design of the HE6.7 engine block and components add reliability and durability you can count on every day, year after year. Both fuel-efficiency and response are significantly enhanced with the Mitsubishi high pressure common rail fuel system. The system delivers high pressure injection, independent of engine speed, for optimum performance and flexibility at every rpm.

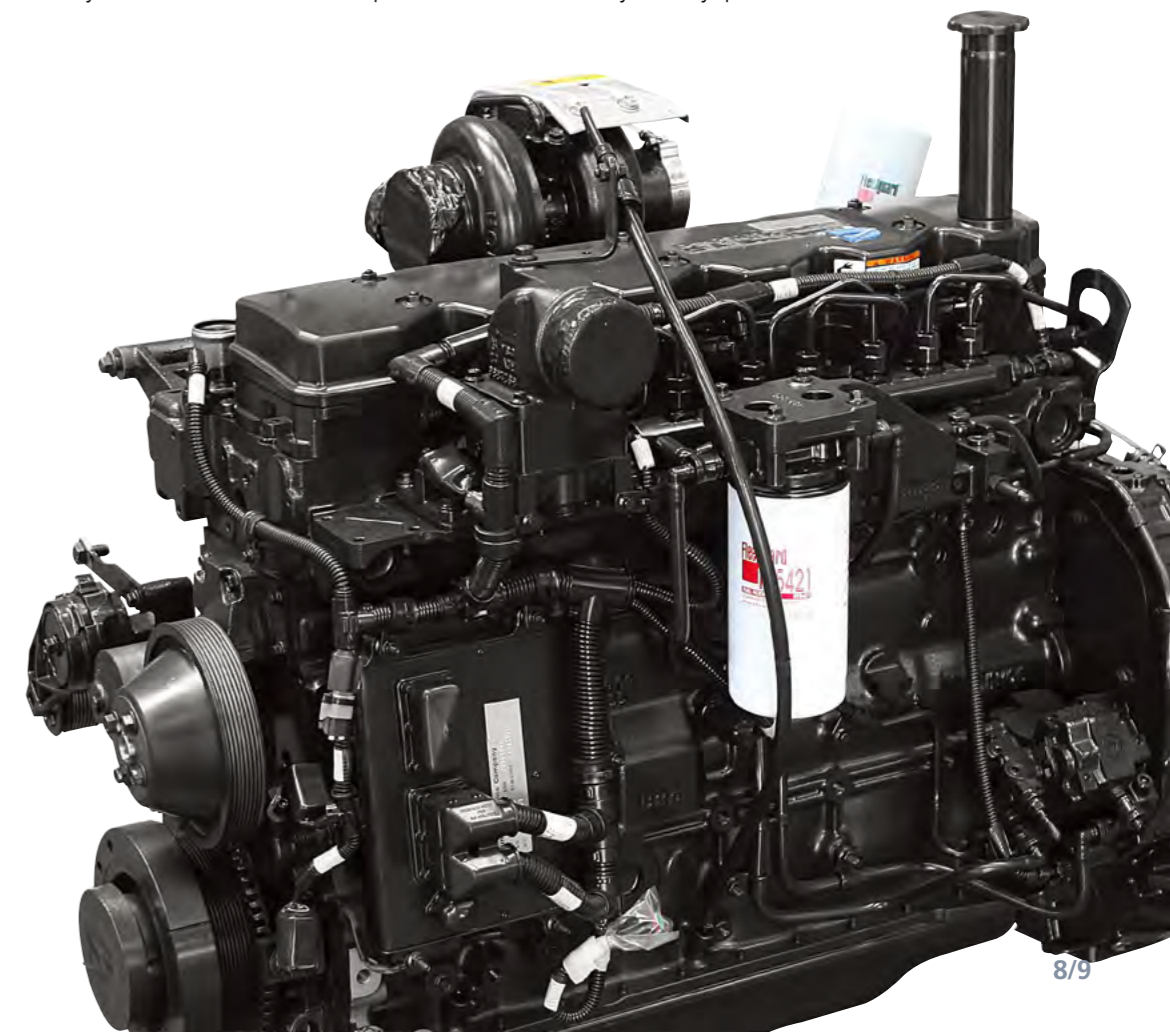

# Profitability

9 series is designed to maximize profitability through improved efficiencies, enhanced service features and longer life components.



\*Photo may include optional equipment.



## Hi-MATE (Remote Management System)

Hi-MATE, Hyundai's proprietary remote management system, provides operators and dealer service personnel access to vital service and diagnostic information on the machine from any computer with internet access. Users can pinpoint machine location using digital mapping and set machine work boundaries, reducing the need for multiple service calls. Hi-mate saves time and money for the owner and dealer by promoting preventative maintenance and reducing machine downtime.

## Fuel Efficiency

9 series excavators are engineered to be extremely fuel efficient. New innovations like fan clutch, the variable speed remote fan, two-stage auto decel system and the new economy mode help to conserve fuel and reduce the impact on the environment.



## Easy Access

Ground-line access to filters, lube fittings, fuses, machine computer components and wide open compartments makes service more convenient on the 9 series.



## Long-Life Components

9 series excavators were designed with bushings designed for long-life lube intervals (250 hrs) & polymer shims (wear resistant, noise reducing), long-life hydraulic filters (1,000hrs), long-life hydraulic oil (5,000hrs), more efficient cooling systems and integrated preheating systems which extend service intervals, minimize operating costs and reduce machine down time.

# Specifications

## ENGINE

MODEL	Hyundai HE6.7		
Type	Water-cooled, 4-cycle diesel, 6-cylinder in-line, Direct injection, Turbocharged, Charge air cooled, Low emission		
Rated flywheel horse power	SAE	J1995 (gross)	151HP (113kW)/ 1,900rpm
		J1349 (net)	143HP (107kW)/ 1,900rpm
	DIN	6271/1 (gross)	153PS (113kW)/ 1,900rpm
		6271/1 (net)	145PS (107kW)/ 1,900rpm
Max. torque	63.6kgf.m (460lb.ft)/1,500rpm		
Bore X stroke	107mm X 124mm (4.2" X 4.9")		
Piston displacement	6,700cc (409 in <sup>3</sup> )		
Batteries	2 X 12V X 100AH		
Starting motor	24V, 4.5kW		
Alternator	24V, 70Amp		

## HYDRAULIC SYSTEM

MAIN PUMP	
Type	Variable displacement tandem-axis piston pumps
Rated flow	2 X 222 L /min (58.6 US gpm/48.8 UK gpm)
Sub-pump for pilot circuit	Gear pump
Cross-sensing and fuel saving pump system.	

HYDRAULIC MOTORS	
Travel	Two speed axial pistons motor with brake valve and parking brake
Swing	Axial piston motor with automatic brake

RELIEF VALVE SETTING	
Implement circuits	350 kgf/cm <sup>2</sup> (4,978 psi)
Travel	350 kgf/cm <sup>2</sup> (4,978 psi)
Power boost (boom, arm, bucket)	380 kgf/cm <sup>2</sup> (5,404 psi)
Swing circuit	265 kgf/cm <sup>2</sup> (3,769 psi)
Pilot circuit	40 kgf/cm <sup>2</sup> (568 psi)
Service valve	Installed

HYDRAULIC CYLINDERS	
No. of cylinder bore X stroke	Boom: 2-120 X 1,290 mm (4.7" X 50.8")
	Arm: 1-140 X 1,510 mm (5.5" X 59.4")
	Bucket: 1-120 X 1,055 mm (4.7" X 41.5")

## DRIVES & BRAKES

Drive method	Fully hydrostatic type
Drive motor	Axial piston motor, in-shoe design
Reduction system	Planetary reduction gear
Max. drawbar pull	21,100 kgf (46,500lb)
Max. travel speed(high) / (low)	5.3 km/hr (3.3 mph) / 3.4 km/hr (2.1 mph)
Gradeability	35° (70 %)
Parking brake	Multi wet disc

## CONTROL

Pilot pressure operated joysticks and pedals with detachable lever provide almost effortless and fatigueless operation.

Pilot control	Two joysticks with one safety lever (LH): Swing and arm, (RH): Boom and bucket(ISO)
Traveling and steering	Two levers with pedals
Engine throttle	Electric, Dial type

## SWING SYSTEM

Swing motor	Two fixed displacement axial pistons motor
Swing reduction	Planetary gear reduction
Swing bearing lubrication	Grease-bathed
Swing brake	Multi wet disc
Swing speed	12.0 rpm

## COOLANT & LUBRICANT CAPACITY

Refilling	liter	US gal	UK gal
Fuel tank	310.0	81.9	68.2
Engine coolant	35.0	9.2	7.7
Engine oil	24.0	6.3	5.3
Swing device-gear oil	5.0	1.3	1.1
Final drive(each)-gear oil	5.8	1.5	1.3
Hydraulic system(including tank)	340.0	89.8	74.8
Hydraulic tank	165.0	43.6	36.3

## UNDERCARRIAGE

The X-leg type center frame is integrally welded with reinforced box-section track frames. The undercarriage includes lubricated rollers, idlers, track adjusters with shock absorbing springs and sprockets, and a track chain with double or triple grouser shoes.

Center frame	X-leg type
Track frame	Pentagonal box type
No. of shoes on each side	49 EA
No. of carrier roller on each side	2 EA
No. of track roller on each side	8 EA
No. of rail guard on each side	2 EA

## OPERATING WEIGHT (APPROXIMATE)







Operating weight, including 5,650mm (18' 6") mono boom, 2,920mm (9' 7") arm, SAE heaped 0.87 m<sup>3</sup> (1.14 yd<sup>3</sup>) backhoe bucket, lubricant, coolant, full fuel tank, hydraulic tank and the standard equipment.

MAJOR COMPONENT WEIGHT	
Upperstructure	5,300 kg (11,680 lb)
Boom (with arm cylinder)	1,950 kg (4,300 lb)
Arm (with bucket cylinder)	1,095 kg (2,410 lb)

OPERATING WEIGHT			
Shoes		Operating weight kg(lb)	Ground pressure kgf/cm2(psi)
Type	width mm(in)		
Triple grouser	500(20)	22,100 (48,720)	0.56 (7.96)
	600(24)		

## BUCKETS

All buckets are welded with high-strength steel.

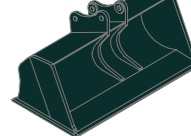
							
SAE heaped m <sup>3</sup> (yd <sup>3</sup> )	0.51 (0.67)	0.80 (1.05)	1.10 (1.44)	1.34 (1.75)	0.74 (0.97)	0.87 (1.14)	0.87 (1.14)
		0.87 (1.14)	1.20 (1.57)		0.90 (1.18)		
		0.92 (1.20)			1.05 (1.37)		

Capacity m <sup>3</sup> (yd <sup>3</sup> )	Width mm (in)	Weight kg (lb)	Recommendation mm (ft.in)						
			5,650 (18' 6") Mono Boom		5,650 (18' 6") Hydraulic Adjustable Boom				
			2,000 (6' 7") Arm	2,400 (7' 10") Arm	2,920 (9' 7") Arm	2,000 (6' 7") Arm	2,400 (7' 10") Arm		
0.51 (0.67)	0.45(0.59)	700(27.6)	820(32.3)	570(1,260)	●	●	●	●	●
0.80 (1.05)	0.70(0.92)	1,000(39.4)	1,120(44.1)	700(1,540)	●	●	●	●	●
0.87 (1.14)	0.75(0.98)	1,090(42.9)	1,210(47.6)	740(1,630)	●	●	●	●	●
0.92 (1.20)	0.80(1.05)	1,150(45.3)	1,270(50.0)	770(1,700)	●	●	■	●	●
1.10 (1.44)	0.96(1.26)	1,320(52.0)	1,440(56.7)	830(1,830)	●	■	▲	■	■
1.20 (1.57)	1.00(1.31)	1,400(55.1)	1,520(59.8)	850(1,870)	●	■	-	■	▲
1.34 (1.75)	1.15(1.50)	1,550(61.0)	1,670(65.7)	920(2,030)	■	▲	-	▲	-
0.74 (0.97)	0.65(0.85)	985(38.8)	-	770(1,700)	●	●	●	●	●
0.90 (1.18)	0.80(1.05)	1,070(42.1)	-	810(1,790)	●	●	■	●	●
1.05 (1.37)	0.92(1.20)	1,290(50.8)	-	890(1,960)	●	■	▲	■	■
0.87 (1.14)	0.75(0.98)	1,140(44.9)	-	900(1,980)	●	●	■	●	●
0.75 (0.98)	0.65(0.85)	1,790(70.5)	-	880(1,940)	●	●	■	●	●

- Heavy duty bucket
- Rock-Heavy duty bucket
- ★ Slope finishing bucket

- : Applicable for materials with density of 2,000 kg /m<sup>3</sup> (3,370 lb/ yd<sup>3</sup>) or less
- : Applicable for materials with density of 1,600 kg /m<sup>3</sup> (2,700 lb/ yd<sup>3</sup>) or less
- ▲ : Applicable for materials with density of 1,100 kg /m<sup>3</sup> (1,850 lb/ yd<sup>3</sup>) or less

## ATTACHMENT

Boom and arms are of all-welded, low-stress, full-box section design. 5,650 mm(18' 6") mono, 5,650 mm(18' 6") Hydraulic Adjustable booms and 2,000 mm (6' 7") 2,400 mm(7' 10"), 2,920 mm(9' 7") arms are available.

## DIGGING FORCE

Boom	Length	mm (ft.in)	5,650 (18' 6")			Remarks
	Weight	kg (lb)	1,790 (3,950)			
Arm	Length	mm (ft.in)	2,000 (6' 7")	2,400 (7' 10")	2,920 (9' 7")	
	Weight	kg (lb)	975 (2,150)	1,045 (2,300)	1,095 (2,410)	
Bucket digging force	SAE	kN	130.4 [144.8]	130.4 [144.8]	130.4 [144.8]	
		kgf	13,300 [14,770]	13,300 [14,770]	13,300 [14,770]	
		lbf	29,320 [32,550]	29,320 [32,550]	29,320 [32,550]	
	ISO	kN	149.1 [165.0]	149.1 [165.0]	149.1 [165.0]	
		kgf	15,200 [16,830]	15,200 [16,830]	15,200 [16,830]	
		lbf	33,510 [37,100]	33,510 [37,100]	33,510 [37,100]	
Arm crowd force	SAE	kN	144.2 [156.5]	119.6 [129.9]	102.0 [110.7]	[ ] : Power Boost
		kgf	14,700 [15,960]	12,200 [13,250]	10,400 [11,290]	
		lbf	32,410 [35,190]	26,930 [29,210]	22,930 [24,900]	
	SAE	kN	151.0 [164.0]	125.5 [136.3]	106.9 [116.1]	
		kgf	15,400 [16,720]	12,800 [13,900]	10,900 [11,830]	
		lbf	33,950 [36,860]	28,220 [30,640]	24,030 [26,090]	

Note : Boom weight includes arm cylinder, piping, and pin.  
Arm weight includes bucket cylinder, linkage, and pin.

## Dimensions & Working Range

### R210NLC-9 MONO BOOM DIMENSIONS

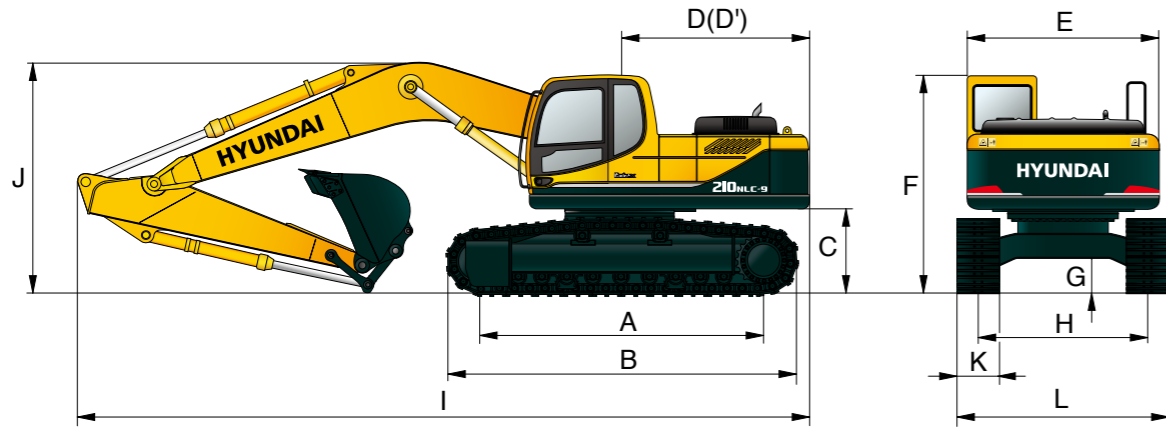

Unit : mm (ft · in)

<b>A</b> Tumbler distance	3,650 (12' 0")
<b>B</b> Overall length of crawler	4,395 (14' 5")
<b>C</b> Ground clearance of counterweight	1,095 (3' 7")
<b>D</b> Tail swing radius	2,800 (9' 2")
<b>D'</b> Rear-end length	2,770 (9' 1")
<b>E</b> Overall width of upperstructure	2,530 (8' 4")
<b>F</b> Overall height of cab	2,955 (9' 8")
<b>G</b> Min. ground clearance	475 (1' 7")
<b>H</b> Track gauge	2,040 (6' 8")

Boom length	5,650 (18' 6")		
Arm length	2,000 (6' 7")	2,400 (7' 10")	2,920 (9' 7")
<b>I</b> Overall length	9,650 (31' 8")	9,570 (31' 5")	9,510 (31' 2")
<b>J</b> Overall height of boom	3,250 (10' 8")	3,170 (10' 5")	3,100 (10' 2")
<b>K</b> Track shoe width	500 (20")	600 (24")	
<b>L</b> Overall width	2,540 (8' 4")	2,640 (8' 8")	

### R210NLC-9 MONO BOOM WORKING RANGE

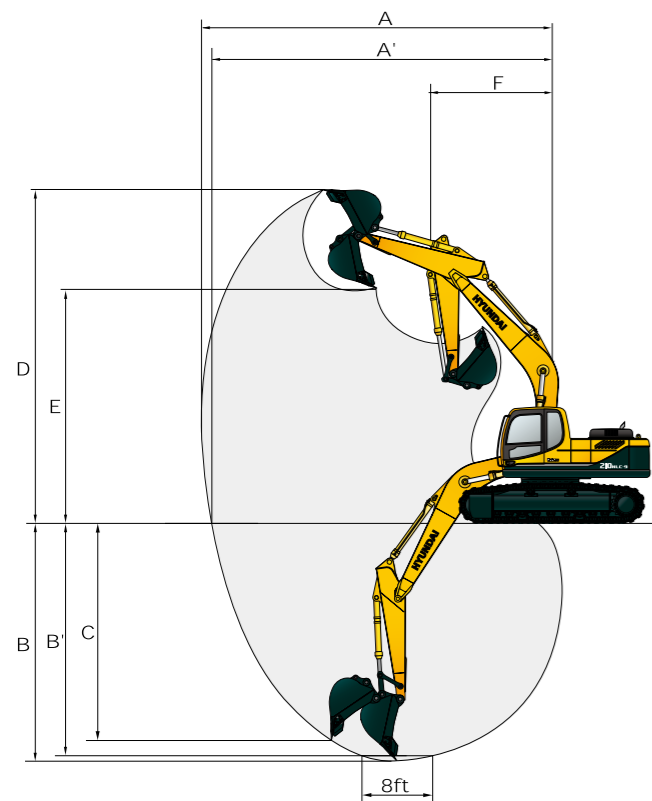

Unit : mm (ft · in)

Boom length	5,650 (18' 6")		
Arm length	2,000 (6' 7")	2,400 (7' 10")	2,920 (9' 7")
<b>A</b> Max. digging reach	9,140 (30' 0")	9,510 (31' 2")	9,960 (32' 8")
<b>A'</b> Max. digging reach on ground	8,960 (29' 5")	9,340 (30' 8")	9,800 (32' 2")
<b>B</b> Max. digging depth	5,750 (18' 10")	6,150 (20' 2")	6,640 (21' 9")
<b>B'</b> Max. digging depth (8' level)	5,520 (18' 1")	5,950 (19' 6")	6,470 (21' 3")
<b>C</b> Max. vertical wall digging depth	5,320 (17' 5")	5,780 (19' 0")	6,250 (20' 6")
<b>D</b> Max. digging height	9,270 (30' 5")	9,500 (31' 2")	9,740 (31' 11")
<b>E</b> Max. dumping height	6,450 (21' 2")	6,660 (21' 10")	6,900 (22' 8")
<b>F</b> Min. swing radius	3,710 (12' 2")	3,630 (11' 11")	3,580 (11' 9")

## Dimensions & Working Range

### R210NLC-9 HYDRAULIC ADJUSTABLE BOOM DIMENSIONS

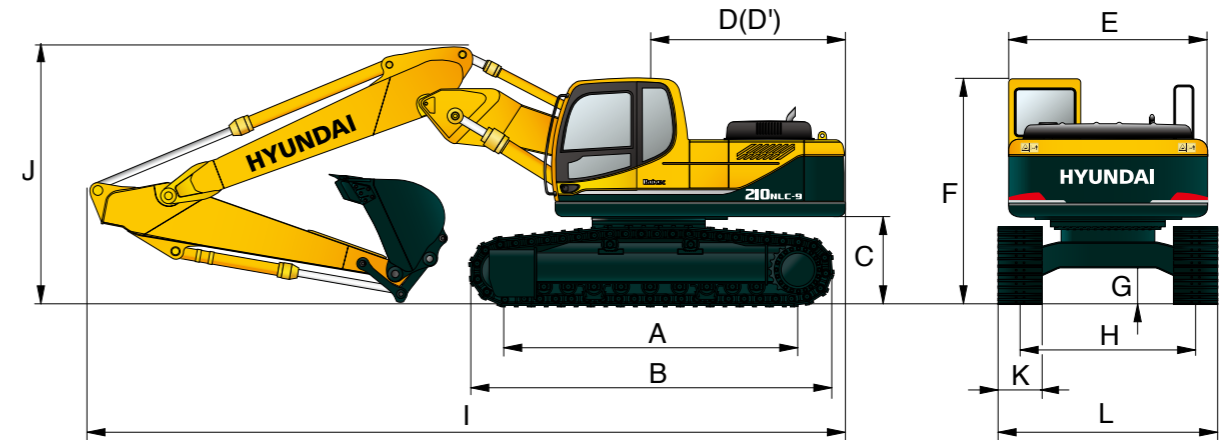

Unit : mm (ft · in)

<b>A</b> Tumbler distance	3,650 (12' 0")
<b>B</b> Overall length of crawler	4,395 (14' 5")
<b>C</b> Ground clearance of counterweight	1,095 (3' 7")
<b>D</b> Tail swing radius	2,800 (9' 2")
<b>D'</b> Rear-end length	2,770 (9' 1")
<b>E</b> Overall width of upperstructure	2,530 (8' 4")
<b>F</b> Overall height of cab	2,955 (9' 8")
<b>G</b> Min. ground clearance	475 (1' 7")
<b>H</b> Track gauge	2,040 (6' 8")

Boom length	5,650 (18' 6")	
Arm length	2,000 (6' 7")	2,400 (7' 10")
<b>I</b> Overall length	9,620 (31' 7")	9,550 (31' 4")
<b>J</b> Overall height of boom	3,050 (10' 0")	3,000 (9' 10")
<b>K</b> Track shoe width	500 (20")	600 (24")
<b>L</b> Overall width	2,540 (8' 4")	2,640 (8' 8")

### R210NLC-9 HYDRAULIC ADJUSTABLE BOOM WORKING RANGE

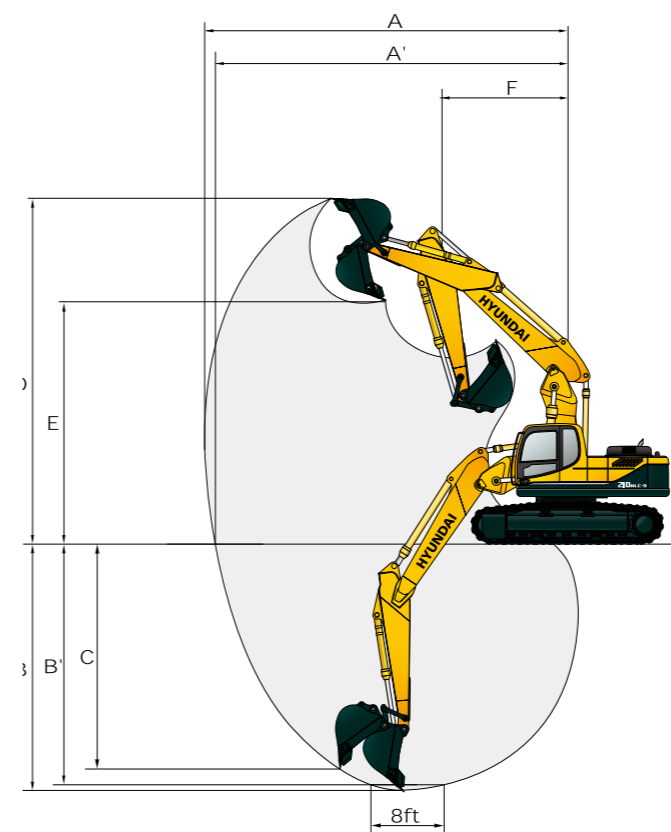

Unit : mm (ft · in)

Boom length	5,650 (18' 6")	
Arm length	2,000 (6' 7")	2,400 (7' 10")
<b>A</b> Max. digging reach	9,120 (29' 11")	9,530 (31' 3")
<b>A'</b> Max. digging reach on ground	8,940 (29' 4")	9,360 (30' 9")
<b>B</b> Max. digging depth	5,480 (17' 12")	5,890 (19' 4")
<b>B'</b> Max. digging depth (8' level)	5,360 (17' 7")	5,770 (18' 11")
<b>C</b> Max. vertical wall digging depth	4,560 (14' 12")	4,990 (16' 4")
<b>D</b> Max. digging height	10,300 (33' 10")	10,670 (35' 0")
<b>E</b> Max. dumping height	7,390 (24' 3")	7,740 (25' 5")
<b>F</b> Min. swing radius	2,870 (9' 5")	2,670 (8' 9")

# Lifting Capacity

## R210NLC-9 MONO BOOM

Boom : 5.65m (18' 6") / Arm : 2.00 m (6' 7") / Bucket : 0.87m<sup>3</sup> (1.14yd<sup>3</sup>)SAE heaped / Shoe : 500mm(20") triple grouser shoe

Load point height m (ft)	Load radius								At max. reach		
	3.0 m (10 ft)		4.5 m (15 ft)		6.0 m (20 ft)		7.5 m (25 ft)		Capacity		Reach
											m (ft)
7.5 m (25 ft)	kg								*4050	3800	6.61
	lb								*8930	8380	(21.7)
6.0 m (20 ft)	kg					*4470	4360		*4120	2800	7.75
	lb					*9850	9610		*9080	6170	(25.4)
4.5 m (15 ft)	kg		*5730	*5730	*4890	4210			*4250	2340	8.41
	lb		*12630	*12630	*10780	9280			*9370	5160	(27.6)
3.0 m (10 ft)	kg		*7480	6130	*5650	3970	*4880	2740	4350	2130	8.71
	lb		*16490	13510	*12460	8750	*10760	6040	9590	4700	(28.6)
1.5 m (5 ft)	kg		*9040	5650	*6440	3730	*5240	2640	4300	2080	8.71
	lb		*19930	12460	*14200	8220	*11550	5820	9480	4590	(28.6)
Ground Line	kg		*9780	5440	*6980	3580	5340	2560	4540	2190	8.40
	lb		*21560	11990	*15390	7890	11770	5640	10010	4830	(27.6)
-1.5 m (-5 ft)	kg	*14220	10460	*9740	5410	*7080	3540		*4980	2530	7.73
	lb	*31350	23060	*21470	11930	*15610	7800		*10980	5580	(25.4)
-3.0 m (-10 ft)	kg	*12730	10670	*8950	5520	*6440	3620		*4950	3360	6.58
	lb	*28060	23520	*19730	12170	*14200	7980		*10910	7410	(21.6)

Boom : 5.65m (18' 6") / Arm : 2.40 m (7' 10") / Bucket : 0.87m<sup>3</sup> (1.14yd<sup>3</sup>) SAE heaped / Shoe : 500mm(20") triple grouser shoe

Load point height m (ft)	Load radius								At max. reach				
	1.5 m (5 ft)		3.0 m (10 ft)		4.5 m (15 ft)		6.0 m (20 ft)		7.5 m (25 ft)		Capacity	Reach	
												m (ft)	
7.5 m (25 ft)	kg										*3740	3340	7.12
	lb										*8250	7360	(23.4)
6.0 m (20 ft)	kg						*4030	*4030			*3820	2530	8.18
	lb						*8880	*8880			*8420	5580	(26.8)
4.5 m (15 ft)	kg				*6900	6220	*4510	4250	*4090	2850	*3950	2140	8.80
	lb				*15210	13710	*9940	9370	*9020	6280	*8710	4720	(28.9)
3.0 m (10 ft)	kg				*8590	5690	*5310	3990	*4600	2740	4050	1950	9.09
	lb				*18940	12540	*11710	8800	*10140	6040	8930	4300	(29.8)
1.5 m (5 ft)	kg				*9560	5410	*6160	3730	*5020	2620	4000	1910	9.08
	lb				*21080	11930	*13580	8220	*11070	5780	8820	4210	(29.8)
Ground Line	kg		*9030	*9030	*9560	5330	*6800	3550	5300	2520	4190	2000	8.79
	lb		*19910	*19910	*21080	11750	*14990	7830	11680	5560	9240	4410	(28.8)
-1.5 m (-5 ft)	kg	*9880	*9880	*13740	10260	*9750	5400	*7030	3480		*4710	2270	8.16
	lb	*21780	*21780	*30290	22620	*21500	11900	*15500	7670		*10380	5000	(26.8)
-3.0 m (-10 ft)	kg	*14280	*14280	*13430	10450	*9200	5400	*6670	3520		*4790	2920	7.09
	lb	*31480	*31480	*29610	23040	*20280	11900	*14700	7760		*10560	6440	(23.3)
-4.5 m (-15 ft)	kg			*10820	*10820	*7500	5640	*6440					
	lb			*23850	*23850	*16530	12430	*14200					

Boom : 5.65m (18' 6") / Arm : 2.40 m (7' 10") / Bucket : 0.87m<sup>3</sup> (1.14yd<sup>3</sup>) SAE heaped / Shoe : 500mm(20") triple grouser shoe

Load point height m (ft)	Load radius								At max. reach				
	1.5 m (5 ft)		3.0 m (10 ft)		4.5 m (15 ft)		6.0 m (20 ft)		7.5 m (25 ft)		Capacity	Reach	
												m (ft)	
7.5 m (25 ft)	kg										*3740	3340	7.12
	lb										*8250	7360	(23.4)
6.0 m (20 ft)	kg						*4030	*4030			*3820	2530	8.18
	lb						*8880	*8880			*8420	5580	(26.8)
4.5 m (15 ft)	kg				*6900	6220	*4510	4250	*4090	2850	*3950	2140	8.80
	lb				*15210	13710	*9940	9370	*9020	6280	*8710	4720	(28.9)
3.0 m (10 ft)	kg				*8590	5690	*5310	3990	*4600	2740	4050	1950	9.09
	lb				*18940	12540	*11710	8800	*10140	6040	8930	4300	(29.8)
1.5 m (5 ft)	kg				*9560	5410	*6160	3730	*5020	2620	4000	1910	9.08
	lb				*21080	11930	*13580	8220	*11070	5780	8820	4210	(29.8)
Ground Line	kg		*9030	*9030	*9560	5330	*6800	3550	5300	2520	4190	2000	8.79
	lb		*19910	*19910	*21080	11750	*14990	7830	11680	5560	9240	4410	(28.8)
-1.5 m (-5 ft)	kg	*9880	*9880	*13740	10260	*9750	5400	*7030	3480		*4710	2270	8.16
	lb	*21780	*21780	*30290	22620	*21500	11900	*15500	7670		*10380	5000	(26.8)
-3.0 m (-10 ft)	kg	*14280	*14280	*13430	10450	*9200	5400	*6670	3520		*4790	2920	7.09
	lb	*31480	*31480	*29610	23040	*20280	11900	*14700	7760		*10560	6440	(23.3)
-4.5 m (-15 ft)	kg			*10820	*10820	*7500	5640	*6440					
	lb			*23850	*23850	*16530	12430	*14200					

- Lifting capacity is based on SAE J1097, ISO 10567.
- Lifting capacity of the Robex Series does not exceed 75% of the tipping load with the machine on firm, level ground or 87% of full hydraulic capacity.
- The load point is a hook located on the back of the bucket.
- (\*) indicates the load limited by hydraulic capacity.

# Lifting Capacity

## R210NLC-9 HYDRAULIC ADJUSTABLE BOOM

Boom : 5.65m (18' 6") / Arm : 2.00 m (6' 7") / Bucket : 0.87m<sup>3</sup> (1.14yd<sup>3</sup>)SAE heaped / Shoe : 500mm(20") triple grouser shoe

Load point height m (ft)	Load radius								At max. reach				
	3.0 m (10 ft)		4.5 m (15 ft)		6.0 m (20 ft)		7.5 m (25 ft)		Capacity		Reach		
											m (ft)		
10.5 m (35 ft)	kg										*5870	*5870	4.92
	lb										*12940	*12940	(16.1)
9.0 m (30 ft)	kg										*6770	*6770	4.30
	lb										*14930	*14930	(14.1)
7.5 m (25 ft)	kg				*6820	*6820					*5440	3930	6.48
	lb				*15040	*15040					*11990	8660	(21.3)
6.0 m (20 ft)	kg				*6920	*6920	*5980	4350			*5040	2850	7.64
	lb				*15260	*15260	*13180	9590			*11110	6280	(25.1)
4.5 m (15 ft)	kg	*11250	*11250	*7810	6730	*6250	4200				4810	2360	8.31
	lb	*24800	*24800	*17220	14840	*13780	9260				10600	5200	(27.3)
3.0 m (10 ft)	kg			*9040	6120	*6720	3950	*5460	2710		4440	2140	8.62
	lb			*19930	13490	*14820	8710	*12040	5970		9790	4720	(28.3)
1.5 m (5 ft)	kg			*9800	5620	*7070	3700	*5430	2600		4390	2090	8.62
	lb			*21610	12390	*15590	8160	11970	5730		9680	4610	(28.3)
Ground Line	kg			*9580	5380	*7000	3540				*4250	2200	8.3
	lb			*21120	11860	*15430	7800				*9370	4850	(27.2)
-1.5 m (-5 ft)	kg	*10550	10360	*8460	5360	*6270	3500				*3710	2560	7.62
	lb	*23260	22840	*18650	11820	*13820	7720				*8180	5640	(25.0)
-3.0 m (-10 ft)	kg			*6340	5480								
	lb			*13980	12080								

Boom : 5.65m (18' 6") / Arm : 2.40 m (7' 10") / Bucket : 0.87m<sup>3</sup> (1.14yd<sup>3</sup>)SAE heaped / Shoe : 500mm(20") triple grouser shoe

Load point height m (ft)	Load radius								At max. reach				
	3.0 m (10 ft)		4.5 m (15 ft)		6.0 m (20 ft)		7.5 m (25 ft)		Capacity		Reach		
											m (ft)		
9.0 m (30 ft)	kg										*5860	*5860	5.13
	lb										*12920	*12920	(16.8)
7.5 m (25 ft)	kg										*5000	3440	7.00
	lb										*11020	7580	(23.0)
6.0 m (20 ft)	kg				*6440	*6440	*5550	4420			*4680	2580	8.07
	lb				*14200	*14200	*12240	9740			*10320	5690	(26.5)
4.5 m (15 ft)	kg	*10170	*10170	*7340	6860	*5960	4250	*3490	2820		4440	2160	8.70
	lb	*22420	*22420	*16180	15120	*13140	9370	*7690	6220		9790	4760	(28.5)
3.0 m (10 ft)	kg	*14030	11450	*8630	6230	*6490	3980	*5310	2710		4130	1960	9.00
	lb	*30930	25240	*19030	13730	*14310	8770	*11710	5970		9110	4320	(29.5)
1.5 m (5 ft)	kg			*9600	5660	*6930	3710	*5420	2590		4070	1910	8.99
	lb			*21160	12480	*15280	8180	11950	5710		8970	4210	(29.5)
Ground Line	kg	*9790	*9790	*9670	5360	*7000	3510	*5300	2490		*4060	2010	8.69
	lb	*21580	*21580	*21320	11820	*15430	7740	*11680	5490		*8950	4430	(28.5)
-1.5 m (-5 ft)	kg	*11850	10160	*8820	5280	*6480	3440				*3650	2300	8.05
	lb	*26120	22400	*19440	11640	*14290	7580				*8050	5070	(26.4)
-3.0 m (-10 ft)	kg	*8940	*8940	*7010	5360	*5050	3490						

