

# Robex 180 LC-9S

With Tier 2 Engine installed



Head Office(Sales Office)  
14F, GLOBAL R&D CENTER, 477 BUNDANG SUSEO-RO, BUNDANG-GU, SEONGNAM-SI, GYEONGGI-DO, 13553, KOREA



Gross Power (SAE J1995)  
126 HP (94 kW) / 2,100 rpm

Net Power (SAE J1349)  
116 HP (87 kW) / 2,100 rpm

Bucket Capacity  
0.39 ~ 1.05m

Operating Weight  
18,350 kg / 40,450 lb

PLEASE CONTACT

# PRIDE AT WORK

Robex **180LC-9S**

Hyundai Heavy Industries strives to build state-of-the-art earthmoving equipment to give every operator maximum performance, more precision, versatile machine preferences, and proven quality.

Take pride in your work with Hyundai!

## Machine Walk-Around

### Engine Technology

Easy & Simple Serviceability / Auto engine warm up feature / Anti-restart feature

### Hydraulic System Improvements

New patented hydraulic control for improved controllability / Improved control valve design for added efficiency and smoother operation / New auto boom and swing priority system for optimum speed / New auto power boost feature for additional power when needed / Improved arm-in and boom-down flow regeneration system for added speed and efficiency

### Pump Compartment

Industry-leading, powerful, reliable Kawasaki designed, variable volume in-line axial piston pumps New compact solenoid block equipped with 4 solenoid valves, 1 EPPR valves, 1 check valve accumulator and pilot filter - controls 2 speed travel, power boost, boom priority, safety lock

### Enhanced Operator Cab

#### Improved Visibility

Enlarged cab with improved visibility  
Larger right-side glass, now one piece, for better right visibility  
Safety glass windows on all sides - less expensive than (polycarbonate) and won't scratch or fade  
Closeable sunshade for operator convenience / Reduced front window seam for improved operator view

#### Improved Cab Construction

New steel tube construction for added operator safety, protection and durability  
New window open/close mechanism designed with cable and spring lift assist and single latch release

#### Improved Suspension Seat / Console Assembly

Ergonomic joysticks with auxiliary control buttons for attachment use - now with new sleek styling  
New joystick consoles - now adjustable in height by way of dial at bottom  
Adjustable arm rests - turn dial to raise or lower for optimum comfort

#### Advanced 7" Color Cluster

New Color LCD Display with easy to read digital gauges for hydraulic oil temperature, water temperature, and fuel / Simplified design makes adjustment and diagnostics easier. Also, new enhanced features such as rear-view camera are integrated into monitor.  
3 power modes : (P) Power, (S) Standard, (E) Economy, 2 work modes : Dig & Attachment, (U) User mode for operator preference  
Enhanced self-diagnostic features with GPS / satellite technology  
One pump flow or two pump flow for optional attachment is now selectable through the cluster.  
/ New anti-theft system with password capability  
Boom speed and arm regeneration are selectable through the monitor.  
Auto power boost is now available - selectable (on/off) through the monitor.  
Powerful air conditioning and heat with auto climate control, 20% more heat and air output than 7 series!

#### RMS

RMS (Remote Management System) works through GPS/satellite technology to ultimately provide better customer service and support.

### Undercarriage

Sealed track chain (urethane seals) / Standard track rail guard / Comfortable bolt-on steps  
Large upper roller cut-outs for debris clean-out / Tapered side frames for debris clean-out  
Grease-type track tensioner



\* Photo may include optional equipment.

### Operator Comfort

In 9S Series cabin you can easily adjust the seat, console and armrest settings to best suit your personal operating preferences.

Seat and console position can be set together and independent from each other.

Other preference settings that add to overall operator comfort include the fully automatic high capacity airconditioning system and the radio / USB player.



### Reduced Stress

Work is stressful enough. Your work environment should be stress free. Hyundai's 9S Series provides improved cab amenities, additional space and a comfortable seat to minimize stress to the operator. A powerful climate control system provides the operator with optimum air temperature. An advanced audio system with USB player, AM/FM stereo is perfect for listening to music favorites.

### Wide Cabin with Excellent Visibility

The newly designed cabin was conceived for more space, a wider field of view and operator comfort. Special attention was given to a clear, open and convenient interior with plenty of visibility on the machine surroundings and the job at hand. This well balanced combination of precision aspects put the operator in the perfect position to work safely and securely.



### Operator - Friendly Cluster

The advanced new cluster with 7 inch wide color LCD screen and toggle switch allows the operator to select his personal machine preferences. Power and work mode selection, self diagnostics, optional rear-view camera, maintenance check lists, start-up machine security were integrated into the cluster to make the machine more versatile and the operator more productive.



# PREFERENCE

Operating a 9S Series is unique to every operator. Operators can fully customize their work environment and operating preferences to fit their individual needs.



\* Photo may include optional equipment.

## COMPUTER AIDED POWER

The engine horsepower and hydraulic horsepower together in unison through the advanced CAPO(Computer Aided Power Optimization) system, flow for the job at hand. Operator can set their own preferences for boom or swing priority, power mode selection and optional work tools at the touch of a button.

The CAPO system also provides complete self diagnostic features and digital gauges for important information like hydraulic oil temperature, water temperatures and fuel level. This system interfaces with multiple sensors placed throughout the hydraulic system as well as hydraulic flow.

### Power Mode

P (Power Max) mode maximizes machine speed and power for mass production. S (Standard) mode provides a reduced, fixed rpm for optimum performance and improved fuel economy. For maximum fuel savings and improved control, E (Economy) mode provides precise flow and power based on load demand. Three unique power modes provide the operator with custom power, speed and fuel economy.

### Work Mode

The work mode allows the operator to select single flow attachments like a hydraulic breaker or bi-directional flow attachments like a crusher. Flow settings unique to each attachment can be programmed from within the cluster.

### User Mode

Some jobs require more precise machine settings. Using the versatile U (User) mode, the operator can customize engine speed, pump output, idle speed and other machine settings for the job at hand.



### Improved Hydraulic System

To achieve optimum precision, Hyundai redesigned the hydraulic system to provide the operator with super fine touch and improved controllability. Improved pump flow control reduces flow when controls are not being used to minimize fuel consumption.

Improved spool valves in the control valve are engineered to provide more precise

flow to each function with less effort.

Improved hydraulic valves, precision-designed variable volume piston pumps, fine-touch pilot controls, and enhanced travel functions make any operator running a 9S Series look like a smooth operator. Newly improved features include arm-in and boom-down flow regeneration, improved control valve technology and innovative auto boom and swing priority for optimal performance in any application.



### Auto Boom-swing Priority

This smart function automatically and continuously looks the ideal hydraulic flow balance for the boom and swing motions of the machine. The advanced CAPO system monitors the hydraulic system and adjusts its settings to maximize performance and productivity.



# PRECISION

Innovative hydraulic system technologies make the 9S Series excavator fast, smooth and easy to control.





# PERFORMANCE

9S Series is designed for maximum performance to keep the operator working productively.

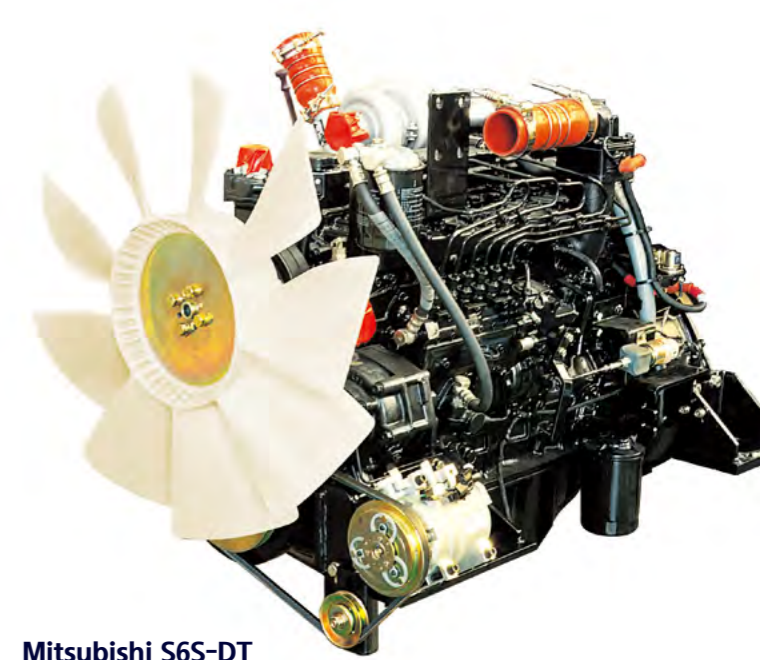

## Mitsubishi S6S-DT

The six cylinders turbo-charged and charged air cooled, engine is built for power, reliability and economy. This engine meets EPA tier II and EU stage II emission regulation.

## Reliability You Can Depend On

Mitsubishi S6S-DT engine is ideal solution for the toughest work environment. The engine is built from a cast iron, skirted block with main bearing support between each cylinder. This combination provides maximum strength, rigidity, and crankshaft support. Special liquid cooling results in uniform temperature distribution.

The compact size of the engine makes it easier to service than other engines. The low engine height allows easy access for maintenance due to a side-mounted, gear-driven camshaft.

## Structure Strength

The 9S Series cabin structure has been fitted with stronger but slimmer tubing for more safety and improved visibility. Low-stress, high strength steel is integrally welded to form a stronger, more durable upper and lower frame. Structural integrity was tested by way of FEM (Finite Elements Method) analysis and long-term durability tests.



## Track Rail Guard & Adjusters

Durable track rail guards keep track links in place. Track adjustment is made easy with standard grease cylinder track adjusters and shock absorbing springs.



Photo may include optional equipment.



# PROFITABILITY

9S Series is designed to maximize profitability through improved efficiencies, enhanced service features and longer life components.



## Hi-MATE

Option

### IT'S CONVENIENT, EASY AND VALUABLE

Hi-MATE Hyundai's newly developed remote management system, utilizes GPS-satellite technology to provide customers with the highest level of service and product support available. Hi-MATE enables users to remotely evaluate machine performance, access diagnostic information, and verify machine locations at the touch of a button.

### WHAT IS BENEFITS



#### Increase Productivity

It helps you operate machines in efficient. You can check the difference between total engine hours and actual working hours. See how productive your machines are and plan any required cost saving solutions. Hi-MATE offers working information such as working / idling hours, fuel consumption and rate.



#### Convenient and Easy Monitoring

There is nothing much to do to monitor your machines. Just log on to the Hi-MATE website or mobile application. Hi-MATE allows you to watch your machines whenever and wherever you are.



#### Security

Protect your machines from theft or unauthorized usage with Hi-MATE. If the machine moves out of the Geo-fence boundary, you will get alerts.

### Fuel Efficiency

9S Series excavators are engineered to be extremely fuel efficient. New innovations like two-stage auto decel system and the new economy mode help to conserve fuel and reduce the impact on the environment.



### Easy Access

Ground-line access to filters, lube fittings, fuses, machine computer components and wide open compartments makes service more convenient on the 9S Series.

### Extended Life Components

9S Series excavators were designed with bushings designed for extended lube intervals (250 hrs) & polymer shims (wear resistant, noise reducing), extended-life hydraulic filters (1,000hrs), long-life hydraulic oil (5,000hrs), more efficient cooling systems and integrated pre-heating systems which extend service intervals, minimize operating costs and reduce machine downtime.

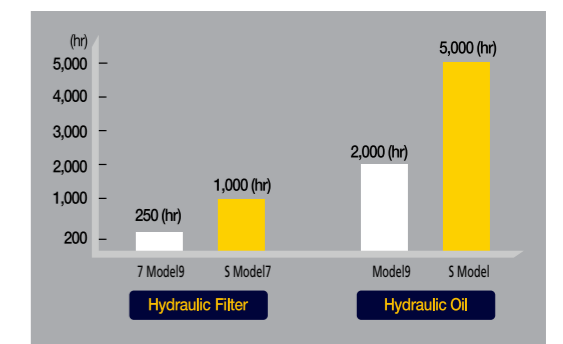

Photo may include optional equipment.

# SPECIFICATIONS

## ENGINE

Maker / Model	Mitsubishi S6S-DT
Type	Water cooled, 4 cycle Diesel, 6-cylinders in line, direct injection, turbocharged charger and air cooled
Gross Power	SAE(J1995) 126 HP (94 kW) / 2,100 rpm DIE(6271/1) 128 PS (94 kW) / 2,100 rpm
Net Power	SAE(J1349) 116 HP (87 kW) / 2,100 rpm DIE(6271/1) 118 PS (87 kW) / 2,100 rpm
Max. torque	42.5 kgf.m (307 lbf.ft) / 1,500 rpm
Bore X stroke	94 x 120mm (3.70" x 4.72")
Piston displacement	4,996cc (305 in <sup>3</sup> )
Batteries	2 X 12V X 100 AH
Starting motor	24V- 5.0kW
Alternator	24V- 50Amp

## HYDRAULIC SYSTEM

### MAIN PUMP

Type	Two variable displacement piston pumps
Rated flow	2 X 160L /min (42.3 US gpm / 35.2 UK gpm)
Sub-pump for pilot circuit	Gear pump

Cross-sensing and fuel saving pump system.

### HYDRAULIC MOTORS

Travel	Two speed axial pistons motor with brake valve and parking brake
Swing	Axial piston motor with automatic brake

### RELIEF VALVE SETTING

Implement Circuits	350 kgf/cm <sup>2</sup> (4,980 psi)
Travel	350 kgf/cm <sup>2</sup> (4,980 psi)
Power Boost (Boom, Arm, Bucket)	380 kgf/cm <sup>2</sup> (5,410 psi)
Swing Circuit	285 kgf/cm <sup>2</sup> (4,050 psi)
Pilot Circuit	40 kgf/cm <sup>2</sup> (570 psi)
Service Valve	Installed

### HYDRAULIC CYLINDERS

	Boom : 2-115 X 1,090 mm (4.5" X 42.9")
No. of Cylinder	Arm : 1-120 X 1,355 mm (4.7" X 53.3")
Bore X Stroke	Bucket : 1-110 X 995 mm (4.3" X 39.2") Blade : 2-110 X 320 mm (4.3" X 12.6")

### DRIVES & BRAKES

Drive Method	Fully hydrostatic type
Drive Motor	Axial piston motor, in-shoe design
Reduction System	Planetary reduction gear
Max. Drawbar Pull	17,000 kgf (37,500 lbf)
Max. Travel Speed (High / Low)	5.5 km/hr(3.4mph) / 3.2 km/hr(2.0mph)
Gradeability	30°(58 %)
Parking Brake	Multi wet disc

### CONTROL

Pilot pressure operated joysticks and pedals with detachable lever provide almost effortless and fatigueless operation.

Pilot Control	Two joysticks with one safety lever (LH): Swing and arm, (RH): Boom and bucket(ISO)
Traveling and Steering	Two levers with pedals
Engine Throttle	Electric, Dial type

## SWING SYSTEM

Swing Motor	Two fixed displacement axial pistons motor
Swing Reduction	Planetary gear reduction
Swing Bearing Lubrication	Grease-bathed
Swing Brake	Multi wet disc
Swing Speed	11 rpm

## COOLANT & LUBRICANT CAPACITY

Refilling	liter	US gal	UK gal
Fuel tank	270	71.3	59.4
Engine coolant	17.5	4.6	3.8
Engine oil	16.5	4.4	3.6
Swing device-gear oil	5.0	1.3	1.1
Final drive(each)-gear oil	5.8	1.5	1.3
Hydraulic system(including tank)	270	71.3	59.4
Hydraulic tank	160	42.6	35.2

## UNDERCARRIAGE

The X-leg type center frame is integrally welded with reinforced box-section track frames. The undercarriage includes lubricated rollers, idlers, track adjusters with shock absorbing springs and sprockets, and a track chain with double or triple grouser shoes.

Center Frame	X - Leg Type
Track Frame	Pentagonal Box Type
No. of Shoes on Each Side	51
No. of Carrier Roller on Each Side	2
No. of Track Roller on Each Side	7
No. of Rail Guard on Each Side	1

## OPERATING WEIGHT (APPROXIMATE)

Operating weight, including 5,100mm (16' 9") boom, 2,600mm (8' 6") arm, SAE heaped 0.76m<sup>3</sup> (0.99 yd<sup>3</sup>) bucket, lubricant, coolant, full fuel tank, full hydraulic tank, and all standard equipments.

### MAJOR COMPONENT WEIGHT

Upperstructure	4,980 kg (10,980 lb)
5.1m (16' 9") mono boom (with arm cylinder)	1,250 kg (2,760 lb)

### OPERATING WEIGHT

Type	Shoes		Operating weight kg(lb)	Ground pressure kgf/cm <sup>2</sup> (psi)
	Width mm(in)			
Triple grouser	500 (20")	R180LC-9S	18,350(40,450)	0.51(7.25)
		R180LCD-9S	19,350(42,660)	0.53(7.54)
		R180NLC-9S	18,260(40,260)	0.50(7.11)
	600 (24")	R180LC-9S	18,600(41,010)	0.43(6.11)
		R180LCD-9S	19,600(43,210)	0.45(6.40)
		R180NLC-9S	18,510(40,810)	0.43(6.11)
700 (28")	R180LC-9S	18,850(41,560)	0.37(5.26)	
	R180LCD-9S	19,850(43,760)	0.39(5.55)	
	R180NLC-9S	18,760(41,360)	0.37(5.26)	
800 (32")	R180LC-9S	19,100(42,110)	0.33(4.69)	
	R180LCD-9S	20,100(44,310)	0.35(4.98)	
	R180NLC-9S	19,010(41,910)	0.33(4.69)	

## AIR CONDITIONING SYSTEM

The air condition system for the machine contains the fluorinated greenhouse gas with global warming potential of R134a. (Global Warming Potential : 1430)

The system hold 0.75kg refrigerant consisting of a CO<sup>2</sup> equivalent 1.07kg metric tonne.

For more information, Please refer to the manual.

# DIMENSIONS & WORKING RANGE

## R180LC-9S DIMENSIONS

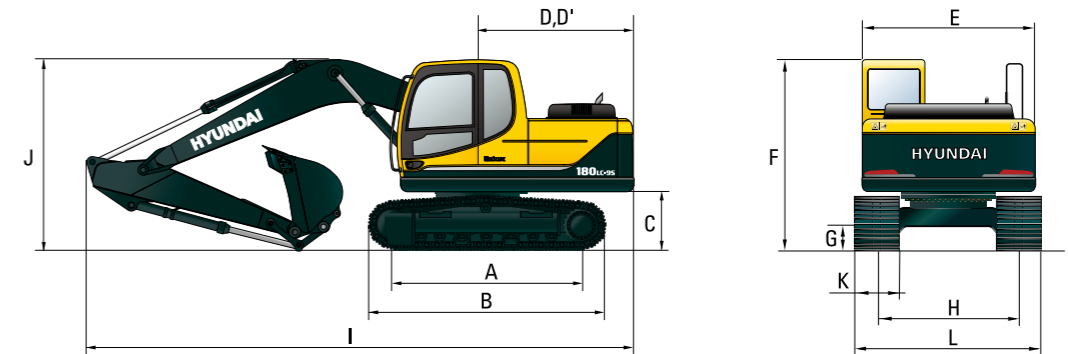

Unit : mm (ft - in)

A Tumbler distance	3,360 (11' 0")
B Overall length of crawler	4,150 (13' 7")
C Ground clearance of counterweight	1,055 (3' 6")
D Tail swing radius	2,530 (8' 4")
D' Rear-end length	2,480 (8' 2")
E Overall width of upperstructure	2,475 (8' 1")
F Overall height of cab	2,980 (9' 9")
G Min. ground clearance	460 (1' 6")
H Track gauge	2,250 (7' 5")

Boom length	5,100(16' 9")		
Arm length	2,200 (7' 3")	2,600 (8' 6")	3,100 (10' 2")
I Overall length	8,660 (28' 5")	8,650 (28' 5")	8,650 (28' 5")
J Overall height of boom	3,010 (9' 11")	2,990 (9' 10")	3,150 (10' 4")
K Track shoe width	500 (20")	600 (24")	700 (28")
L Overall width	2,750 (9' 1")	2,850 (9' 5")	2,950 (9' 9")

## R180LC-9S WORKING RANGE

Unit : mm (ft - in)

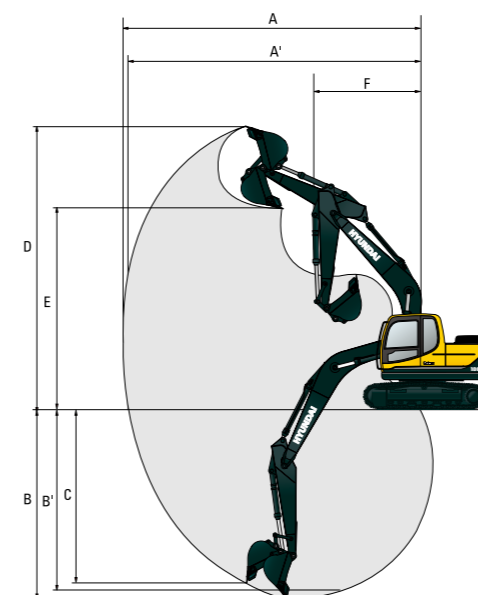

Boom length	5,100(16' 9")		
Arm length	2,200 (7' 3")	2,600 (8' 6")	3,100 (10' 2")
A Max. digging reach	8,690 (28' 6")	9,020 (29' 7")	9,450 (31' 0")
A' Max. digging reach on ground	8,530 (27' 12")	8,860 (29' 1")	9,300 (30' 6")
B Max. digging depth	5,660 (18' 7")	6,060 (19' 11")	6,560 (21' 6")
B' Max. digging depth (8' level)	5,430 (17' 10")	5,850 (19' 2")	6,370 (20' 11")
C Max. vertical wall digging depth	5,120 (16' 10")	5,380 (17' 8")	5,710 (18' 9")
D Max. digging height	8,750 (28' 8")	8,840 (29' 0")	8,980 (29' 6")
E Max. dumping height	6,110 (20' 1")	6,220 (20' 5")	6,390 (21' 0")
F Min. swing radius	3,180 (10' 5")	3,170 (10' 5")	3,170 (10' 5")

# DIMENSIONS & WORKING RANGE

## R180NLC-9S DIMENSIONS

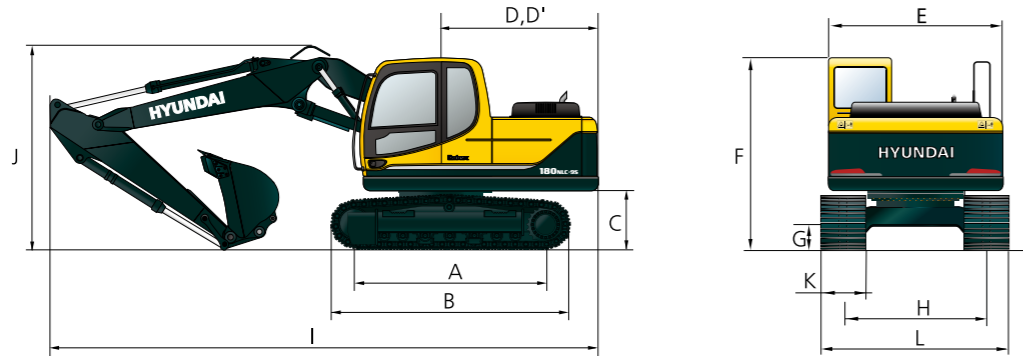

Unit : mm (ft - in)

A Tumbler distance	3,360 (11' 0")
B Overall length of crawler	4,150 (13' 7")
C Ground clearance of counterweight	1,055 (3' 6")
D Tail swing radius	2,530 (8' 4")
D' Rear-end length	2,480 (8' 2")
E Overall width of upperstructure	2,475 (8' 1")
F Overall height of cab	2,990 (9' 10")
G Min. ground clearance	460 (1' 6")
H Track gauge	2,000 (6' 7")

Boom length	5,100(16' 9")		
Arm length	2,200 (7' 3")	2,600 (8' 6")	3,100 (10' 2")
I Overall length	8,660 (28' 5")	8,650 (28' 5")	8,650 (28' 5")
J Overall height of boom	3,010 (9' 11")	2,990 (9' 10")	3,150 (10' 4")
K Track shoe width	500 (20")	600 (24")	700 (28")
L Overall width	2,500 (8' 2")	2,600 (8' 6")	2,700 (8' 10")

## R180LCD-9S DIMENSIONS

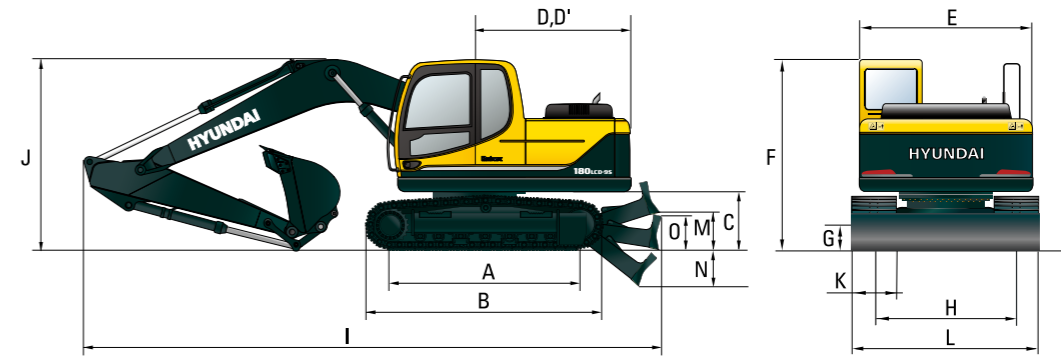

Unit : mm (ft - in)

A Tumbler distance	3,360 (11' 0")
B Overall length of crawler	4,150 (13' 7")
C Ground clearance of counterweight	1,055 (3' 6")
D Tail swing radius	2,530 (8' 4")
D' Rear-end length	2,480 (8' 2")
E Overall width of upperstructure	2,475 (8' 1")
F Overall height of cab	2,980 (9' 9")
G Min. ground clearance	460 (1' 6")
H Track gauge	2,250 (7' 5")
M Ground clearance of blade up	615 (2' 0")
N Depth of blade down	675 (2' 3")
O Height of blade	640 (2' 1")

Boom length	5,100(16' 9")			
Arm length	2,200 (7' 3")	2,600 (8' 6")	3,100 (10' 2")	
I Overall length	9,110 (29' 11")	9,100 (29' 10")	9,100 (29' 10")	
J Overall height of boom	3,010 (9' 11")	2,990 (9' 10")	3,150 (10' 4")	
K Track shoe width	500 (20")	600 (24")	700 (28")	800 (32")
L Overall width	2,750 (9' 1")	2,850 (9' 5")	2,950 (9' 9")	3,050 (10' 1")

## R180NLC-9S WORKING RANGE

Unit : mm (ft - in)

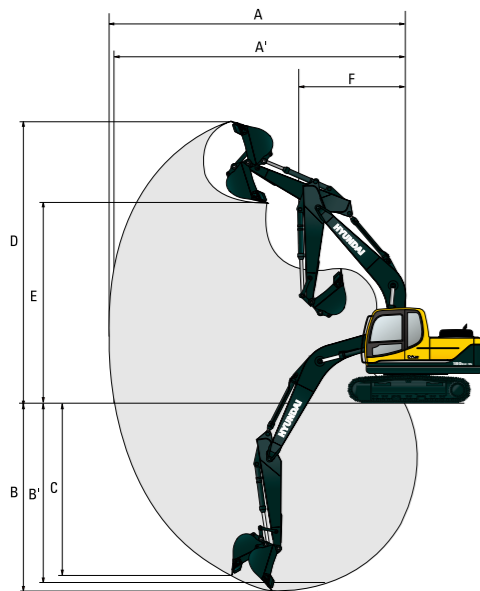

Boom length	5,100(16' 9")		
Arm length	2,200 (7' 3")	2,600 (8' 6")	3,100 (10' 2")
A Max. digging reach	8,690 (28' 6")	9,020 (29' 7")	9,450 (31' 0")
A' Max. digging reach on ground	8,530 (27' 12")	8,860 (29' 1")	9,300 (30' 6")
B Max. digging depth	5,660 (18' 7")	6,060 (19' 11")	6,560 (21' 6")
B' Max. digging depth (8' level)	5,430 (17' 10")	5,850 (19' 2")	6,370 (20' 11")
C Max. vertical wall digging depth	5,120 (16' 10")	5,380 (17' 8")	5,710 (18' 9")
D Max. digging height	8,750 (28' 8")	8,840 (29' 0")	8,980 (29' 6")
E Max. dumping height	6,110 (20' 1")	6,220 (20' 5")	6,390 (21' 0")
F Min. swing radius	3,180 (10' 5")	3,170 (10' 5")	3,170 (10' 5")

## R180LCD-9S WORKING RANGE

Unit : mm (ft - in)

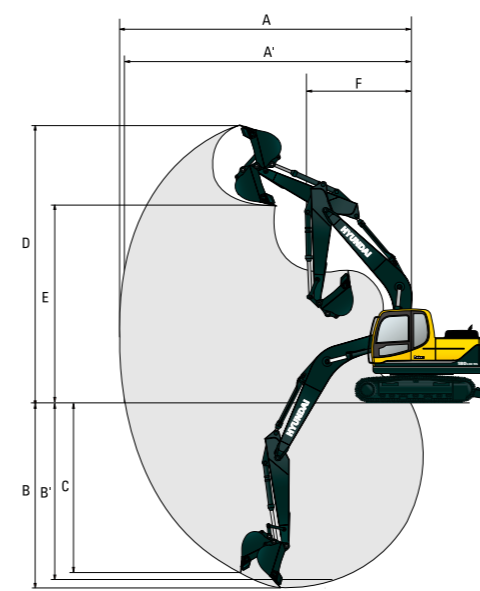











Boom length	5,100 (16' 9")			
Arm length	2,200 (7' 3")	2,600 (8' 6")	3,100 (10' 2")	
A Max. digging reach	8,690 (28' 6")	9,020 (29' 7")	9,450 (31' 0")	
A' Max. digging reach on ground	8,530 (27' 12")	8,860 (29' 1")	9,300 (30' 6")	
B Max. digging depth	5,660 (18' 7")	6,060 (19' 11")	6,560 (21' 6")	
B' Max. digging depth (8' level)	5,430 (17' 10")	5,850 (19' 2")	6,370 (20' 11")	
C Max. vertical wall digging depth	5,120 (16' 10")	5,380 (17' 8")	5,710 (18' 9")	
D Max. digging height	8,750 (28' 8")	8,840 (29' 0")	8,980 (29' 6")	
E Max. dumping height	6,110 (20' 1")	6,220 (20' 5")	6,390 (21' 0")	
F Min. swing radius	3,180 (10' 5")	3,170 (10' 5")	3,170 (10' 5")	

# LIFTING CAPACITY













 Rating over-front  Rating over-side or 360 degree

## R180LC-9S

Boom : 5.10 m (16' 9") / Arm : 2.20 m (7' 3") / Bucket : 0.76 m<sup>3</sup> (0.92 yd<sup>3</sup>) SAE heaped / Shoe : 600mm(24") triple grouser

Lift-point height (m/ft)	Lift-point radius								At max. reach			
	1.5 m (5 ft)		3.0 m (10 ft)		4.5 m (15 ft)		6.0 m (20 ft)		Capacity		Reach	
											m (ft)	
7.5 m (25 ft)	kg									*3,770	*3,750	5.60
	lb									*8,270	*8,270	(18.4)
6.0 m (20 ft)	kg									*3,660	2,920	6.98
	lb									*8,070	6,440	(22.9)
4.5 m (15 ft)	kg					*4,570	*4,570	*4,110	3,690	*3,690	2,370	7.76
	lb					*10,080	*10,080	*9,060	8,140	*8,140	5,220	(25.5)
3.0 m (10 ft)	kg			*9,100	*9,100	*5,790	5,620	*4,600	3,550	3,360	2,130	8.15
	lb			*20,060	*20,060	*12,760	12,390	*10,140	7,830	7,410	4,700	(26.7)
1.5 m (5 ft)	kg					*7,030	5,250	*5,160	3,390	3,280	2,060	8.20
	lb					*15,500	11,570	*11,380	7,470	7,230	4,540	(26.9)
Ground Line	kg			*7,120	*7,120	*7,680	5,030	5,250	3,270	3,420	2,150	7.94
	lb			*15,700	*15,700	*16,930	11,090	11,570	7,210	7,540	4,740	(26.0)
-1.5 m (-5ft)	kg	*7,040	*7,040	*11,150	9,670	*7,590	4,970	5,200	3,230	3,900	2,450	7.31
	lb	*15,520	*15,520	*24,580	21,320	*16,730	10,960	11,460	7,120	8,600	5,400	(24.0)
-3.0 m (-10ft)	kg	*11,230	*11,230	*9,630	*9,630	*6,670	5,030			*3,750	3,240	6.19
	lb	*24,760	*24,760	*21,230	*21,230	*14,700	11,090			*8,270	7,140	(20.3)
-4.5 m (-15ft)	kg			*6,270	*6,270							
	lb			*13,820	*13,820							

Boom : 5.10 m (16' 9") / Arm : 2.60 m (8' 6") / Bucket : 0.76 m<sup>3</sup> (0.92 yd<sup>3</sup>) SAE heaped / Shoe : 600mm(24") triple grouser













Lift-point height (m/ft)	Lift-point radius										At max. reach			
	1.5 m (5 ft)		3.0 m (10 ft)		4.5 m (15 ft)		6.0 m (20 ft)		7.5 m (25 ft)		Capacity		Reach	
													m (ft)	
7.5 m (25 ft)	kg											*3,380	*3,380	6.11
	lb											*7,450	*7,450	(20.0)
6.0 m (20 ft)	kg							*3,020	*3,020			*3,360	2,660	7.37
	lb							*6,660	*6,660			*7,410	5,860	(24.2)
4.5 m (15 ft)	kg							*3,770	3,720			*3,410	2,190	8.11
	lb							*8,310	8,200			*7,520	4,830	(26.6)
3.0 m (10 ft)	kg			*7,910	*7,910	*5,310	*5,310	*4,300	3,560	*2,810	2,420	3,130	1,970	8.48
	lb			*17,440	*17,440	*11,710	*11,710	*9,480	7,850	*6,190	5,340	6,900	4,340	(27.8)
1.5 m (5 ft)	kg			*8,120	*8,120	*6,650	5,270	*4,920	3,380	*3,650	2,350	3,050	1,900	8.53
	lb			*17,900	*17,900	*14,660	11,620	*10,850	7,450	*8,050	5,180	6,720	4,190	(28.0)
Ground Line	kg			*7,910	*7,910	*7,500	5,010	5,220	3,240	*3,470	2,280	3,170	1,970	8.28
	lb			*17,440	*17,440	*16,530	11,050	11,510	7,140	*7,650	5,030	6,990	4,340	(27.2)
-1.5 m (-5 ft)	kg	*6,710	*6,710	*10,690	9,550	*7,620	4,900	5,140	3,170			3,560	2,220	7.69
	lb	*14,790	*14,790	*23,570	21,050	*16,800	10,800	11,330	6,990			7,850	4,890	(25.2)
-3.0 m (-10 ft)	kg	*9,990	*9,990	*10,280	9,680	*6,960	4,930	*4,870	3,200			*3,750	2,830	6.64
	lb	*22,020	*22,020	*22,660	21,340	*15,340	10,870	*10,740	7,050			*8,270	6,240	(21.8)
-4.5 m (-15 ft)	kg			*7,470	*7,470	*4,960	*4,960							
	lb			*16,470	*16,470	*10,930	*10,930							

- 1 | Lifting capacity are based on ISO 10567.
- 2 | Lifting capacity of HX Series does not exceed 75% of tipping load with the machine on firm, level ground or 87% of full hydraulic capacity.
- 3 | The Lift-point is bucket pivot mounting pin on the arm(without bucket mass).
- 4 | (\*) indicates load limited by hydraulic capacity.

 Rating over-front  Rating over-side or 360 degree

## R180LC-9S

Boom : 5.10 m (16' 9") / Arm : 3.10 m (11' 1") / Bucket : 0.76 m<sup>3</sup> (0.92 yd<sup>3</sup>) SAE heaped / Shoe : 600mm(24") triple grouser

Lift-point height (m/ft)	Lift-point radius										At max. reach														
	1.5 m (5 ft)		3.0 m (10 ft)		4.5 m (15 ft)		6.0 m (20 ft)		7.5 m (25 ft)		Capacity		Reach												
													m (ft)												
7.5 m (25 ft)	kg												*3,000	*3,000	6.73										
	lb												*6,610	*6,610	(22.1)										
6.0 m (20 ft)	kg												*2,870	*2,870	7.88										
	lb												*6,330	*6,330	(25.9)										
4.5 m (15 ft)	kg												*3,350	*3,350	*2,130	*2,130	*3,100	1,970	8.57						
	lb												*7,390	*7,390	*4,700	*4,700	*6,830	4,340	(28.1)						
3.0 m (10 ft)	kg												*4,710	*4,710	*3,930	3,580	*3,090	2,420	2,870	1,780	8.91				
	lb												*10,380	*10,380	*8,660	7,890	*6,810	5,340	6,330	3,920	(29.2)				
1.5 m (5 ft)	kg														*10,220	*10,220	*6,160	5,330	*4,620	3,380	3,730	2,330	2,790	1,710	8.96
	lb														*22,530	*22,530	*13,580	11,750	*10,190	7,450	8,220	5,140	6,150	3,770	(29.4)
Ground Line	kg														*8,670	*8,670	*7,210	5,010	*5,180	3,220	3,640	2,250	2,880	1,760	8.73
	lb														*19,110	*19,110	*15,900	11,050	*11,420	7,100	8,020	4,960	6,350	3,880	(28.6)
-1.5 m (-5 ft)	kg	*6,310	*6,310	*10,330	9,460	*7,580	4,850	5,090	3,120	*3,230	2,210	3,190	1,960	8.17											
	lb	*13,910	*13,910	*22,770	20,860	*16,710	10,690	11,220	6,880	*7,120	4,870	7,030	4,320	(26.8)											
-3.0 m (-10 ft)	kg	*8,950	*8,950	*10,900	9,520	*7,200	4,830	5,080	3,110					*3,630	2,430	7.21									
	lb	*19,730	*19,730	*24,030	20,990	*15,870	10,650	11,200	6,860					*8,000	5,360	(23.7)									
-4.5 m (-15 ft)	kg	*12,430	*12,430	*8,640	*8,640	*5,790	4,950							*3,370	*3,370	5.59									
	lb	*27,400	*27,400	*19,050	*19,050	*12,760	10,910							*7,430	*7,430	(18.3)									











- 1 | Lifting capacity are based on ISO 10567.
- 2 | Lifting capacity of HX Series does not exceed 75% of tipping load with the machine on firm, level ground or 87% of full hydraulic capacity.
- 3 | The Lift-point is bucket pivot mounting pin on the arm(without bucket mass).
- 4 | (\*) indicates load limited by hydraulic capacity.

# LIFTING CAPACITY

 Rating over-front  Rating over-side or 360 degree

## R180NLC-9S













Boom : 5.10 m (16' 9") / Arm : 2.20 m (7' 3") / Bucket : 0.76 m<sup>3</sup> (0.92 yd<sup>3</sup>) SAE heaped / Shoe : 600mm(24") triple grouser

Lift-point height (m/ft)	Lift-point radius										At max. reach	
	1.5 m (5 ft)		3.0 m (10 ft)		4.5 m (15 ft)		6.0 m (20 ft)		Capacity		Reach	
											m (ft)	
7.5 m (25 ft)	kg									*3,750	*3,750	5.60
	lb									*8,270	*8,270	(18.4)
6.0 m (20 ft)	kg									*3,660	2,550	6.98
	lb									*8,070	5,620	(22.9)
4.5 m (15 ft)	kg					*4,570	*4,570	*4,110	3,230	3,680	2,060	7.76
	lb					*10,080	*10,080	*9,060	7,120	8,110	4,540	(25.5)
3.0 m (10 ft)	kg			*9,100	*9,100	*5,790	4,880	*4,600	3,100	3,340	1,830	8.15
	lb			*20,060	*20,060	*12,760	10,760	*10,140	6,830	7,360	4,030	(26.7)
1.5 m (5 ft)	kg					*7,030	4,530	*5,160	2,940	3,260	1,770	8.20
	lb					*15,500	9,990	*11,380	6,480	7,190	3,900	(26.9)
Ground Line	kg			*7,120	*7,120	*7,680	4,320	5,220	2,820	3,400	1,840	7.94
	lb			*15,700	*15,700	*16,930	9,520	11,510	6,220	7,500	4,060	(26.0)
-1.5 m (-5ft)	kg	*7,040	*7,040	*11,150	8,100	*7,590	4,250	5,160	2,780	3,870	2,110	7.31
	lb	*15,520	*15,520	*24,580	17,860	*16,730	9,370	11,380	6,130	8,530	4,650	(24.0)
-3.0 m (-10ft)	kg	*11,230	*11,230	*9,630	8,250	*6,670	4,310			*3,750	2,800	6.19
	lb	*24,760	*24,760	*21,230	18,190	*14,700	9,500			*8,270	6,170	(20.3)
-4.5 m (-15ft)	kg			*6,270	*6,270							
	lb			*13,820	*13,820							

 Rating over-front  Rating over-side or 360 degree

## R180NLC-9S

Boom : 5.10 m (16' 9") / Arm : 3.10 m (11' 1") / Bucket : 0.76 m<sup>3</sup> (0.92 yd<sup>3</sup>) SAE heaped / Shoe : 600mm(24") triple grouser

Lift-point height (m/ft)	Lift-point radius										At max. reach												
	1.5 m (5 ft)		3.0 m (10 ft)		4.5 m (15 ft)		6.0 m (20 ft)		7.5 m (25 ft)		Capacity		Reach										
													m (ft)										
7.5 m (25 ft)	kg												*3,000	2,790	6.73								
	lb												*6,610	6,150	(22.1)								
6.0 m (20 ft)	kg												*2,870	*2,870	*3,020	2,050	7.88						
	lb												*6,330	*6,330	*6,660	4,520	(25.9)						
4.5 m (15 ft)	kg												*3,350	3,280	*2,130	*2,130	*3,100	1,690	8.57				
	lb												*7,390	7,230	*4,700	*4,700	*6,830	3,730	(28.1)				
3.0 m (10 ft)	kg												*4,710	*4,710	*3,930	3,120	*3,090	2,090	2,850	1,520	8.91		
	lb												*10,380	*10,380	*8,660	6,880	*6,810	4,610	6,280	3,350	(29.2)		
1.5 m (5 ft)	kg																						
	lb																						
Ground Line	kg																						
	lb																						
-1.5 m (-5 ft)	kg	*6,310	*6,310	*10,330	7,890	*7,580	4,140	5,060	2,670	*3,230	1,880												
	lb	*13,910	*13,910	*22,770	17,390	*16,710	9,130	11,160	5,890	*7,120	4,140												
-3.0 m (-10 ft)	kg	*8,950	*8,950	*10,900	7,950	*7,200	4,120	5,040	2,660														
	lb	*19,730	*19,730	*24,030	17,530	*15,870	9,080	11,110	5,860														
-4.5 m (-15 ft)	kg	*12,430	*12,430	*8,640	8,170	*5,790	4,240																
	lb	*27,400	*27,400	*19,050	18,010	*12,760	9,350																













1 | Lifting capacity are based on ISO 10567.

2 | Lifting capacity of HX Series does not exceed 75% of tipping load with the machine on firm, level ground or 87% of full hydraulic capacity.

3 | The Lift-point is bucket pivot mounting pin on the arm(without bucket mass).

4 | (\*) indicates load limited by hydraulic capacity.

Boom : 5.10 m (16' 9") / Arm : 2.60 m (8' 6") / Bucket : 0.76 m<sup>3</sup> (0.92 yd<sup>3</sup>) SAE heaped / Shoe : 600mm(24") triple grouser

Lift-point height (m/ft)	Lift-point radius										At max. reach												
	1.5 m (5 ft)		3.0 m (10 ft)		4.5 m (15 ft)		6.0 m (20 ft)		7.5 m (25 ft)		Capacity		Reach										
													m (ft)										
7.5 m (25 ft)	kg												*3,380	3,290	6.11								
	lb												*7,450	7,250	(20.0)								
6.0 m (20 ft)	kg												*3,360	2,320	7.37								
	lb												*7,410	5,110	(24.2)								
4.5 m (15 ft)	kg												*3,770	3,250	*3,410	1,890	8.11						
	lb												*8,310	7,170	*7,520	4,170	(26.6)						
3.0 m (10 ft)	kg																						
	lb																						
1.5 m (5 ft)	kg																						
	lb																						
Ground Line	kg																						
	lb																						
-1.5 m (-5ft)	kg	*6,710	*6,710	*10,690	7,980	*7,620	4,190	5,110	2,720														
	lb	*14,790	*14,790	*23,570	17,590	*16,800	9,240	11,270	6,000														
-3.0 m (-10ft)	kg	*9,990	*9,990	*10,280	8,100	*6,960	4,210	*4,870	2,750														
	lb	*22,020	*22,020	*22,660	17,860	*15,340	9,280	*10,740	6,060														
-4.5 m (-15ft)	kg																						
	lb																						

1 | Lifting capacity are based on ISO 10567.

2 | Lifting capacity of HX Series does not exceed 75% of tipping load with the machine on firm, level ground or 87% of full hydraulic capacity.

3 | The Lift-point is bucket pivot mounting pin on the arm(without bucket mass).











4 | (\*) indicates load limited by hydraulic capacity.

# LIFTING CAPACITY













 Rating over-front  Rating over-side or 360 degree

## R180LCD-9S

Boom : 5.10 m (16' 9") / Arm : 2.20 m (7' 3") / Bucket : 0.76 m<sup>3</sup> (0.92 yd<sup>3</sup>) SAE heaped / Shoe : 600mm(24") triple grouser

Lift-point height (m/ft)	Lift-point radius								At max. reach			
	1.5 m (5ft)		3.0 m (10ft)		4.5 m (15ft)		6.0 m (20ft)		Capacity		Reach	
											m (ft)	
7.5 m (25 ft)	kg									*3,750	*3,750	5.60
	lb									*8,270	*8,270	(18.4)
6.0 m (20 ft)	kg									*3,660	3,070	6.98
	lb									*8,070	6,770	(22.9)
4.5 m (15 ft)	kg					*4,570	*4,570	*4,110	3,880	*3,690	2,510	7.76
	lb					*10,080	*10,080	*9,060	8,550	*8,140	5,530	(25.5)
3.0 m (10 ft)	kg			*9,100	*9,100	*5,790	*5,790	*4,600	3,740	*3,760	2,260	8.15
	lb			*20,060	*20,060	*12,760	*12,760	*10,140	8,250	*8,290	4,980	(26.7)
1.5 m (5 ft)	kg					*7,030	5,530	*5,160	3,580	3,740	2,190	8.20
	lb					*15,500	12,190	*11,380	7,890	8,250	4,830	(26.9)
Ground Line	kg			*7,120	*7,120	*7,680	5,310	*5,520	3,460	3,910	2,280	7.94
	lb			*15,700	*15,700	*16,930	11,710	*12,170	7,630	8,620	5,030	(26.0)
-1.5 m (-5ft)	kg	*7,040	*7,040	*11,150	10,180	*7,590	5,240	*5,450	3,420	*3,960	2,600	7.31
	lb	*15,520	*15,520	*24,580	22,440	*16,730	11,550	*12,020	7,540	*8,730	5,730	(24.0)
-3.0 m (-10ft)	kg	*11,230	*11,230	*9,630	*9,630	*6,670	5,300			*3,750	3,420	6.19
	lb	*24,760	*24,760	*21,230	*21,230	*14,700	11,680			*8,270	7,540	(20.3)
-4.5 m (-15ft)	kg			*6,270	*6,270							
	lb			*13,820	*13,820							

Boom : 5.10 m (16' 9") / Arm : 2.60 m (8' 6") / Bucket : 0.76 m<sup>3</sup> (0.92 yd<sup>3</sup>) SAE heaped / Shoe : 600mm(24") triple grouser













Lift-point height (m/ft)	Lift-point radius										At max. reach			
	1.5 m (5 ft)		3.0 m (10 ft)		4.5 m (15 ft)		6.0 m (20 ft)		7.5 m (25 ft)		Capacity		Reach	
													m (ft)	
7.5 m (25 ft)	kg											*3,380	*3,380	6.11
	lb											*7,450	*7,450	(20.0)
6.0 m (20 ft)	kg							*3,020	*3,020			*3,360	2,800	7.37
	lb							*6,660	*6,660			*7,410	6,170	(24.2)
4.5 m (15 ft)	kg							*3,770	*3,770			*3,410	2,320	8.11
	lb							*8,310	*8,310			*7,520	5,110	(26.6)
3.0 m (10 ft)	kg			*7,910	*7,910	*5,310	*5,310	*4,300	3,750	*2,810	2,570	*3,500	2,090	8.48
	lb			*17,440	*17,440	*11,710	*11,710	*9,480	8,270	*6,190	5,670	*7,720	4,610	(27.8)
1.5 m (5 ft)	kg			*8,120	*8,120	*6,650	5,550	*4,920	3,570	*3,650	2,490	3,490	2,020	8.53
	lb			*17,900	*17,900	*14,660	12,240	*10,850	7,870	*8,050	5,490	7,690	4,450	(28.0)
Ground Line	kg			*7,910	*7,910	*7,500	5,280	*5,380	3,430	*3,470	2,430	3,630	2,100	8.28
	lb			*17,440	*17,440	*16,530	11,640	*11,860	7,560	*7,650	5,360	8,000	4,630	(27.2)
-1.5 m (-5 ft)	kg	*6,710	*6,710	*10,690	11,060	*7,620	5,180	*5,460	3,360			*3,810	2,360	7.69
	lb	*14,790	*14,790	*23,570	22,180	*16,800	11,420	*12,040	7,410			*8,400	5,200	(25.2)
-3.0 m (-10 ft)	kg	*9,990	*9,990	*10,280	10,180	*6,960	5,200	*4,870	3,390			*3,750	3,000	6.64
	lb	*22,020	*22,020	*22,660	22,440	*15,340	11,460	*10,740	7,470			*8,270	6,610	(21.8)
-4.5 m (-15 ft)	kg			*7,470	*7,470	*4,960	*4,960							
	lb			*16,470	*16,470	*10,930	*10,930							

- 1 | Lifting capacity are based on ISO 10567.
- 2 | Lifting capacity of HX Series does not exceed 75% of tipping load with the machine on firm, level ground or 87% of full hydraulic capacity.
- 3 | The Lift-point is bucket pivot mounting pin on the arm(without bucket mass).
- 4 | (\*) indicates load limited by hydraulic capacity.

 Rating over-front  Rating over-side or 360 degree

## R180LCD-9S

Boom : 5.10 m (16' 9") / Arm : 3.10 m (11' 1") / Bucket : 0.76 m<sup>3</sup> (0.92 yd<sup>3</sup>) SAE heaped / Shoe : 600mm(24") triple grouser

Lift-point height (m/ft)	Lift-point radius										At max. reach											
	1.5 m (5 ft)		3.0 m (10 ft)		4.5 m (15 ft)		6.0 m (20 ft)		7.5 m (25 ft)		Capacity		Reach									
													m (ft)									
7.5 m (25 ft)	kg											*3,000	*3,000	6.73								
	lb											*6,610	*6,610	(22.1)								
6.0 m (20 ft)	kg									*2,870	*2,870	*3,020	2,490	7.88								
	lb									*6,330	*6,330	*6,660	5,490	(25.9)								
4.5 m (15 ft)	kg									*3,350	*3,350	*2,130	*2,130	*3,100	2,090	8.57						
	lb									*7,390	*7,390	*4,700	*4,700	*6,830	4,610	(28.1)						
3.0 m (10 ft)	kg									*4,710	*4,710	*3,930	3,770	*3,090	2,570	*3,200	1,890	8.91				
	lb									*10,380	*10,380	*8,660	8,310	*6,810	5,670	*7,050	4,170	(29.2)				
1.5 m (5 ft)	kg											*10,220	*10,220	*6,160	5,600	*4,620	3,570	*3,850	2,470	3,200	1,830	8.96
	lb											*22,530	*22,530	*13,580	12,350	*10,190	7,870	*8,490	5,450	7,050	4,030	(29.4)
Ground Line	kg											*8,670	*8,670	*7,210	5,280	*5,180	3,410	*4,100	2,390	3,310	1,880	8.73
	lb											*19,110	*19,110	*15,900	11,640	*11,420	7,520	*9,040	5,270	7,300	4,140	(28.6)
-1.5 m (-5 ft)	kg	*6,310	*6,310	*10,330	9,960	*7,580	5,120	*5,420	3,310	*3,230	2,350	*3,570	2,090	8.17								
	lb	*13,910	*13,910	*22,770	21,960	*16,710	11,290	*11,950	7,300	*7,120	5,180	*7,870	4,610	(26.8)								
-3.0 m (-10 ft)	kg	*8,950	*8,950	*10,900	10,020	*7,200	5,110	*5,110	3,300			*3,630	2,580	7.21								
	lb	*19,730	*19,730	*24,030	22,090	*15,870	11,270	*11,270	7,280			*8,000	5,690	(23.7)								
-4.5 m (-15 ft)	kg	*12,430	*12,430	*8,640	*8,640	*5,790	5,230					*3,370	*3,370	5.59								
	lb	*27,400	*27,400	*19,050	*19,050	*12,760	11,530					*7,430	*7,430	(18.3)								

- 1 | Lifting capacity are based on ISO 10567.
- 2 | Lifting capacity of HX Series does not exceed 75% of tipping load with the machine on firm, level ground or 87% of full hydraulic capacity.
- 3 | The Lift-point is bucket pivot mounting pin on the arm(without bucket mass).
- 4 | (\*) indicates load limited by hydraulic capacity.

# BUCKET SELECTION GUIDE & DIGGING FORCE

## BUCKETS



0.39(0.51)

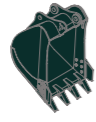

0.50(0.65)



0.64(0.84)



0.76(0.99)



0.89(1.16)



1.05(1.37)



0.69(0.90)

SAE heaped  
m<sup>3</sup> (yd<sup>3</sup>)

Capacity m <sup>3</sup> (yd <sup>3</sup> )		Width mm (in)		Weight kg (lb)	Recommendation mm (ft.in)		
SAE heaped	CECE heaped	Without side cutters	With side cutters		5,100 (16' 9") Mono Boom		
					2,200 (7' 3") Arm	2,600 (8' 6") Arm	3,100 (10' 2") Arm
0.39(0.51)	0.34(0.44)	620(24.4)	740(29.1)	410(900)	●	●	●
0.50(0.65)	0.44(0.58)	760(29.9)	880(34.6)	470(1,040)	●	●	●
0.64(0.84)	0.55(0.72)	920(36.2)	1,040(40.9)	510(1,120)	●	●	■
0.76(0.99)	0.65(0.85)	1,060(41.7)	1,180(46.5)	570(1,260)	●	■	▲
0.89(1.16)	0.77(1.01)	1,220(48.0)	1,340(52.8)	610(1,340)	■	▲	-
1.05(1.37)	0.90(1.18)	1,400(55.1)	1,520(59.8)	680(1,500)	▲	-	-
0.69(0.90)	0.62(0.81)	990(39.0)	-	700(1,540)	●	■	▲

■ Heavy duty bucket

● : Applicable for materials with density of 2,000 kgf/m<sup>3</sup> (3,370 lbf/yd<sup>3</sup>) or less  
 ■ : Applicable for materials with density of 1,600 kgf/m<sup>3</sup> (2,700 lbf/yd<sup>3</sup>) or less  
 ▲ : Applicable for materials with density of 1,100 kgf/m<sup>3</sup> (1,850 lbf/yd<sup>3</sup>) or less

## ATTACHMENT

Booms and arms are welded with a low-stress, full-box section design. 5.65 m, 5.68 m & 8.2 m Booms and 2.0 m, 2.4 m, 2.92 m, 3.9 m & 6.3 m Arms are available.

## DIGGING FORCE

Boom	Length	mm (ft.in)	5,100 (16' 9")			Remark
	Weight	kg (lb)	1,250 (2,760)			
Arm	Length	mm (ft.in)	2,200 (7' 3")	2,600 (8' 6")	3,100 (10' 2")	Power Boost
	Weight	kg (lb)	750 (1,560)	810 (1,790)	890 (1,960)	
Bucket digging force	SAE	kN	107.9 [117.2]	107.9 [117.2]	107.9 [117.2]	[ ]: Power Boost
		kgf	11,000 [11,940]	11,000 [11,940]	11,000 [11,940]	
		lbf	24,250 [26,330]	24,250 [26,330]	24,250 [26,330]	
	ISO	kN	123.6 [134.2]	123.6 [134.2]	123.6 [134.2]	
		kgf	12,600 [13,680]	12,600 [13,680]	12,600 [13,680]	
		lbf	27,780 [30,160]	27,780 [30,160]	27,780 [30,160]	
Arm crowd force	SAE	kN	87.2 [94.7]	77.3 [83.9]	69.0 [74.9]	
		kgf	8,890 [9,650]	7,880 [8,560]	7,030 [7,630]	
		lbf	19,600 [21,280]	17,370 [18,860]	15,500 [16,830]	
	ISO	kN	91.0 [98.8]	80.3 [87.2]	71.4 [77.5]	
		kgf	9,280 [10,080]	8,190 [8,890]	7,280 [7,900]	
		lbf	20,460 [22,210]	18,060 [19,600]	16,050 [17,430]	

Note : Boom weight includes arm cylinder, piping, and pin  
 Arm weight includes bucket cylinder, linkage, and pin

# STANDARD / OPTION

## STANDARD EQUIPMENT

<b>ISO Standard cabin</b>
All-weather steel cab with 360° visibility
Safety glass windows
Rise-up type windshield wiper
Sliding fold-in front window
Sliding side window(LH)
Lockable door
Hot & cool box
Storage compartment & Ashtray
Radio & USB player
Cabin roof-steel cover
12 volt power outlet (24V DC to 12V DC converter)
<b>Computer aided power optimization (New CAPO) system</b>
3-power mode, 2-work mode, user mode
Auto deceleration & one-touch deceleration system
Auto warm-up system
Auto overheat prevention system
<b>Automatic climate control</b>
Air conditioner & heater
Defroster
<b>Self-diagnostics system</b>
<b>Starting Aid (air grid heater) for cold weather</b>
<b>Centralized monitoring</b>
LCD display
Engine speed or Trip meter / Accel
Clock
Gauges
Fuel level gauge
Engine coolant temperature gauge
Hyd. oil temperature gauge
Warnings
Overload
Communication error
Low battery
Air cleaner clogging
Indicators
Max power
Low speed/High speed
Fuel warmer
Auto idle
<b>Door and cab locks, one key</b>
<b>Two outside rearview mirrors</b>
<b>Fully adjustable suspension seat with seat belt</b>
<b>Pilot-operated slidable joystick</b>
<b>Four front working lights (2 boom mounted, 2 front frame mounted)</b>
<b>Electric horn</b>
<b>Batteries (2 x 12V x 100 AH)</b>
<b>Battery master switch</b>
<b>Removable clean-out dust net for cooler</b>
<b>Automatic swing brake</b>
<b>Removable reservoir tank</b>
<b>Fuel pre-filter</b>
<b>Boom holding system</b>
<b>Arm holding system</b>
<b>Track shoes (600mm, 24")</b>
<b>Track rail guard</b>
<b>Accumulator for lowering work equipment</b>
<b>Electric transducer</b>
<b>Lower frame under cover (Normal)</b>

## OPTIONAL EQUIPMENT

<b>Fuel filler pump (35 L/min)</b>
<b>Beacon lamp</b>
<b>Single-acting piping kit (breaker, etc.)</b>
<b>Double-acting piping kit (clamshell, etc.)</b>
<b>Quick coupler</b>
<b>Travel alarm</b>
<b>Booms</b>
5.1 m, 16' 9"
<b>Arms</b>
2.2 m, 7' 3"
2.6 m, 8' 6"
3.1 m, 10' 2"
<b>Cabin FOPS/FOG (ISO/DIS 10262 Level II)</b>
FOPS (Falling Object Protective Structure)
FOG (Falling Object Guard)
<b>Cabin lights</b>
<b>Cabin front window rain guard</b>
<b>Sun visor</b>
<b>Track shoes</b>
Triple grousers shoe (500mm, 20")
Triple grousers shoe (700mm, 28")
Triple grousers shoe (800 mm, 32")
<b>Lower frame under cover (Additional)</b>
<b>Tool kit</b>
<b>Operator suit</b>
<b>Rearview camera</b>
<b>Seat</b>
Mechanical suspension seat with heater
<b>Hi-mate (Remote Management System)</b>
<b>Fuel warmer</b>
<b>Air compressor</b>
<b>Cabin-winenet guard / Finenet guard</b>
<b>Blade</b>
640mm (2' 1") x 2,750mm (9' 1")
640mm (2' 1") x 2,850mm (9' 5")
640mm (2' 1") x 3,050mm (10' 1")

\* Standard and optional equipment may vary. Contact your Hyundai dealer for more information. The machine may vary according to International standards.  
 \* The photos may include attachments and optional equipment that are not available in your area.  
 \* Materials and specifications are subject to change without advance notice.  
 \* All imperial measurements rounded off to the nearest pound or inch.