

HL985A

With EU Stage V Engine installed

*Photo may include optional equipment.



Head Office(Sales Office)
14F, GLOBAL R&D CENTER, 477 BUNDANG SUSEO-RO, BUNDANG-GU, SEONGNAM-SI, GYEONGGI-DO, 13553, KOREA

PLEASE CONTACT

Gross Power
430 HP (321 kW) 2,100 rpm

Net Power
420 HP (313 kW) 2,100 rpm

Bucket Capacity
6.5 ~ 7.0 m³

Operating Weight
33,800kg / 74,520 lb

WHAT'S NEWEST AND BEST

HL985A

THE BEST PRODUCTIVITY AND FUEL EFFICIENCY

- EU STAGE V Engine **NEW**
- Eco Report **NEW**
- Smart Power Mode **NEW**
- Hydraulic Differential Lock **Option**
- 5 Speed Lock Up Clutch
- ICCO (Intelligent Clutch Cut Off)
- Automatic Engine Shutdown
- Optimized Power Matching

ULTIMATE DURABILITY

- Enhanced Rear Axle Capacity **NEW**
- Axle Oil Cooling System
- Thermostat for Transmission Cooling
- Optimized Drive Shaft
- High Quality Hydraulic Hose

EASY CONTROL AND COMFORTABLE OPERATION

- Electric Side Mirror **NEW**
- Fully Adjustable Seat and Armrest **NEW**
- Air Compressor **NEW** **Option**
- Remote Door Control **NEW** **Option**
- Auto Greasing System **Option**
- Ride Control **Option**
- Full Sound-Proofed Spacious Cabin
- Wide Touch Screen Monitor
- Centralized Cluster
- Soft end Stop
- Weighing System
- EH Joystick Steering

THE ULTIMATE SAFE ENVIRONMENT

- Emergency Stop **NEW**
- Seat Belt Warning Alarm **NEW**
- Radar **NEW** **Option**
- AVM (Around View Monitoring) **Option**
- IMOD (Intelligent Moving Object Detection) **Option**

SERVICEABILITY AND TELEMATICS

- ECD(Engine Connected Diagnostics) **NEW**
- Fully Openable Engine Hood **NEW**
- Hi MATE **Option**
- Easy Filter Replacement
- Wide Core & Fin Radiator



* Photo may include optional equipment.



THE BEST PRODUCTIVITY AND FUEL EFFICIENCY

The new HYUNDAI HL985A with new engine technologies is satisfying the most strict environmental emission regulation in the world and A series in wheel loader have a number of new features that contribute to overall fuel and also production efficiency



* Photo may include optional equipment

Eco Report **NEW**

Eco report shows the wheel loader's inefficient operation status in order to improve operator's improper working habit.



5 Speed Lock Up Clutch

By using of 5 Speed & lock up clutch, now operator can enjoy both the reduction of Fuel consumption and various of use in gears depends on the working condition.

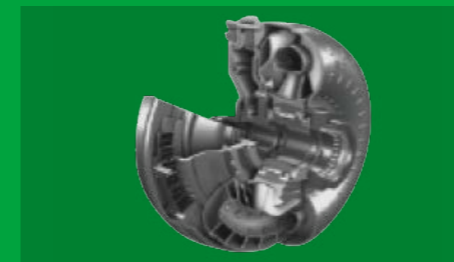

Hydraulic Differential Lock

Hydraulic differential lock has the advantages of both improving productivity and less fuel consumption by preventing tire slip during the operation.

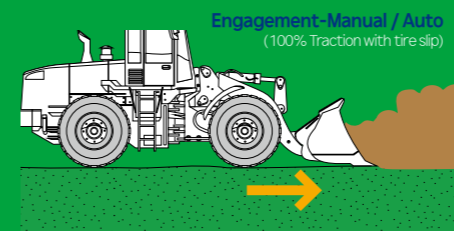

ICCO(IntelligentClutchCutOff)

By selecting of 'H-Mode' among clutch cut-off selections, ICCO will be engaged for both less power loss in torque converter and lower heat generation on brake sides.

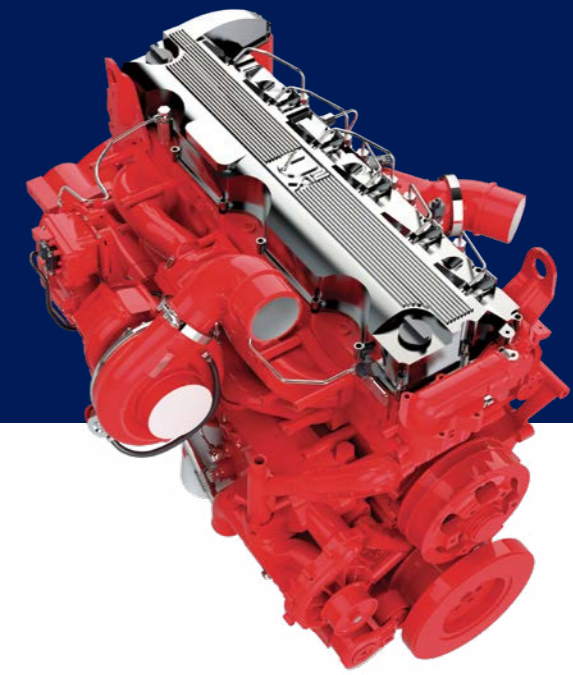
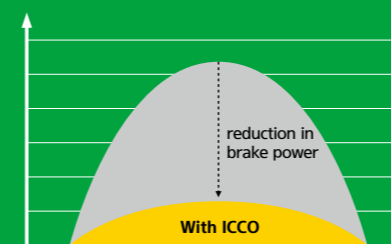

EU STAGE V Engine **NEW**

'Cummins X12' engine meeting Euro Stage V emission regulations is designed for maximum productivity and fuel efficiency.

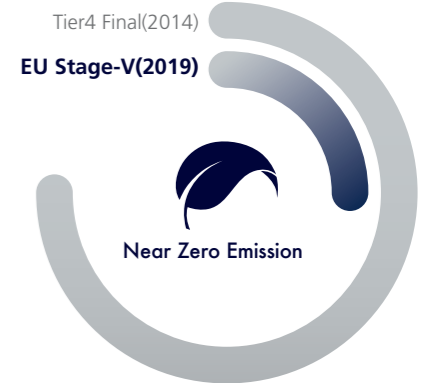

Smart Power Mode **NEW**

Smart Power mode reduces fuel consumption by adjusting the engine speed in heavy load work like digging. The key point of this function is not only saving fuel with same performance as Power mode but also making good balance between traction force and breakout force.



Automatic Engine Shutdown

Adjustable 'Automatic Engine Shutdown' significantly reduces idle time, overall operating hours and fuel consumption.



Optimized Power Matching

For maximum operational efficiency, the engine is designed to achieve high torque in the low RPM range. Change an engine rpm at peak torque to lower rpm section also.

Enhanced Rear Axle Capacity **NEW**

HL985A applied larger capacity axle than the previous series. It offers more reliable performance and longer durability.

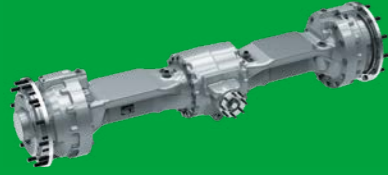

Axle Oil Cooling System

Axle oil cooling system prevents overheating of axle oil caused by frequent braking and high-load work.

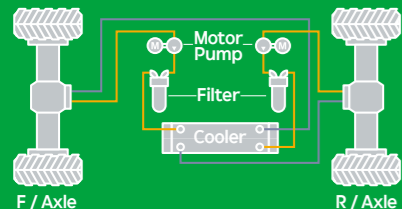

Thermostat for Transmission Cooling

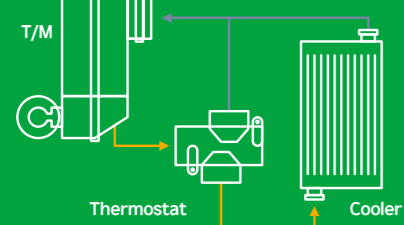

Optimized Drive Shaft

Through thorough verification, the optimized drive shaft makes the HL985A wheel loader more durable.

High Quality Hydraulic Hose

High quality hydraulic hoses increased durability and product life cycle.



ULTIMATE DURABILITY

The true value of the HL985A, which is now far more powerful, is revealed in tough working environments. With the high-strength design structure and enduring system proven by rigorous road tests at various work sites, Hyundai wheel loaders can perform any high-load work to maximize productivity.



* Photo may include optional equipment.

Air Compressor **NEW** Option

Air Compressor will be used for cleaning inside the cabin and for operator self-cleaning.



Full Sound-Proofed Spacious Cabin

State-of-the-art noise reduction technology of the HL985A ensures maximum silence(72 dB) in the same category of equipment, promising more silent and more pleasant interior space.



Remote Door Control **NEW** Option

Remote door control allows operators to open the cabin door remotely. This system was developed for the convenience and safety of the operator.



Wide Touch Screen Monitor

The seven-inch capacitive-type display (like a smart phone display) provides excellent legibility.



Centralized Cluster

With a centralized cluster, operator can see at a glance all the states of wheel loader.



Weighing System

The HL985A further improves work precision with additional weight calibration. The automatic/manual cumulative weighing function greatly enhances operating efficiency. Icons displaying weighing errors and the two-color weight value indication on the monitor enable accurate weighing to support efficient production management.



Soft End Stop

When an attachment reaches at the end stroke, it gives operator enormous shock especially for Boom up. This function gives shock free operation by reducing the speed of attachment near the end stroke. It can be selected on/off through Monitor.



Electric Side Mirror **NEW**

Electric side mirrors prevent damage when transporting narrow space.



Fully Adjustable Seat and Armrest **NEW**

This suspension will be applied for minimizing an operator's fatigue.



Ride Control **Option**

Ride control system reduces operator fatigue and material spillage during operation. An accumulator helps to minimize shock, giving the operator a much smoother ride.

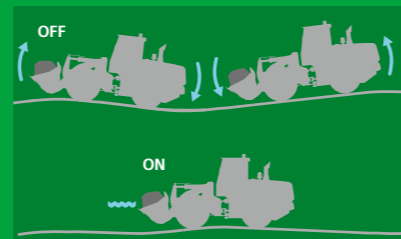

Auto Greasing System **Option**

Auto greasing system is designed to automatically lubricate when it is needed. Uniform application of lubricant ensures that the lubrication points always have the correct amount of grease.



* Photo may include optional equipment.



EASY CONTROL AND COMFORTABLE OPERATION

The HL985A is optimized to enable operators to access accurate equipment data in a timely manner. This feature is more important in tough working environments to increase productivity while enjoying various forms of entertainment. Enjoy unparalleled satisfaction provided by infotainment of Hyundai's state-of-the-art information technology!



HL985A with advanced technology ensures our safety on a construction site. //

The A Series in wheel loaders are products of HCE's spirit of initiative, creativity, and strong drive. HCE engineers, who are the best in the industry, have worked tirelessly to offer a zero-defect product. The new A Series in wheel loader reflects customers' needs in the field gleaned by thorough monitoring.

Emergency Stop **NEW**

In an emergency, operating the Emergency Stop switch located at the bottom of the seat will shut down the engine starting.



Seat Belt Warning Alarm **NEW**

Seat belt warning alarm allows the operator to work in a safer environment.



Radar **NEW** Option

The Radar system can detect rear obstacles without blind spots and no distinction between day and night. Also, the warning level of the nearest obstacle is always displayed on the secondary monitor.



AVM(Around View Monitoring) **Option**

IMOD(Intelligent Moving Object Detection) **Option**

This is a system that is combined AVM (Around View Monitoring) with IMOD (Intelligent Moving Object Detection) and detects people around the machine and analyzes the images, which displays a warning sign on a monitor when detecting the danger. So operators can watch the surroundings in a variety of angles through the monitor and prevent the safety accident in advance.

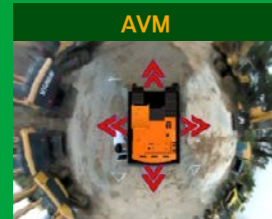

It displays the position of people with a top view.



A green warning sign is displayed when people move in within a 5-meters radius.



A red warning sign is displayed when people move in within a 3-meters radius.



THE ULTIMATE SAFE ENVIRONMENT

With the top priority on satisfaction of operators in terms of silence, safety and maintainability, Hyundai wheel loaders provide operators with comfortable cabin space by low-vibration, low-noise, and superior safety design. They also offer greater satisfaction by extending the replacement cycle of supplies and minimizing maintenance time and cost.



* Photo may include optional equipment.



SERVICEABILITY AND TELEMATICS

IoT, ICT, AI-based digital technologies is creating smart construction sites. Maximizes connectivity, productivity, and safety for your successful businesses.



* Photo may include optional equipment.

HiMATE

Option

IT'S CONVENIENT, EASY AND VALUABLE

Hi MATE Hyundai's newly developed remote management system, utilizes GPS-satellite technology to provide customers with the highest level of service and product support available. Hi MATE enables users to remotely evaluate machine performance, access diagnostic information, and verify machine locations at the touch of a button.

WHAT IS BENEFITS



Increase Productivity

It helps you operate machines in efficient. You can check the difference between total engine hours and actual working hours. See how productive your machines are and plan any required cost saving solutions. Hi MATE offers working information such as working / idling hours, fuel consumption and rate.



Convenient and Easy Monitoring

There is nothing much to do to monitor your machines. Just log on to the Hi MATE website or mobile application. Hi MATE allows you to watch your machines whenever and wherever you are.



Security

Protect your machines from theft or unauthorized usage with Hi MATE. If the machine moves out of the Geofence boundary, you will get alerts.

ECD(Engine Connected Diagnostics) **NEW**

It supports service technician with remote diagnostics report and ensure it arrive on site with proper tools after preparing in advance.

We are all connected

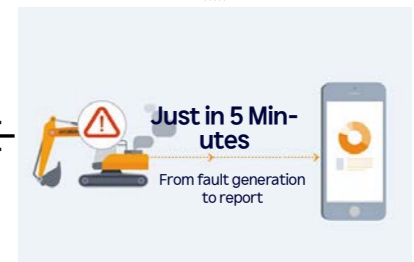
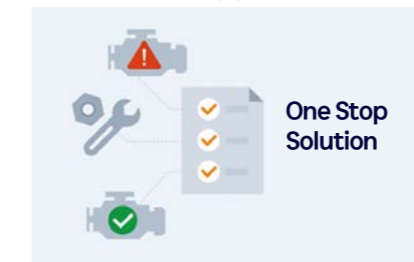

Fully Openable Engine Hood **NEW**

The HL985A has improved accessibility to the sealed engine room with retractable hood to allow easy cleaning and maintenance. The engine room was designed to prevent possibility of fire due to inflow of foreign materials. The fully retractable engine hood in the electric actuator opening mode also enhances maintainability of the engine room and cooling room.



Easy Filter Replacement

With easy filter replacement, machine can be managed more easily.



Wide Core & Fin Radiator

Wide core & fin radiator reduces clogging.



HL985A SPECIFICATIONS

ENGINE

Maker / Model	CUMMINS / X12 / EU Stage V
Type	6 cylinder, Watercooled, 4-cycle, turbocharged, charge air cooled, direct injection, electronic controlled diesel engine.
Gross power (SAE J1995)	430 HP (321 kW) at 2,100 rpm
Net power (SAE J1349)	420 HP (313 kW) at 2,100 rpm
Max. Power	473 HP (353 kW) at 1,700 rpm
Peak Gross Torque (SAE J1995)	2,300 N·m (1,696 lb.ft) at 1,400 rpm
Displacement	11.8 ℓ (720 cu in)

TRANSMISSION

Travel speed	5 Speed T/M with lock up clutch	
		km/h (mph)
Forward	1st	6.2 (3.9)
	2nd	11.9 (7.4)
	3rd	18.5 (11.5)
	4th	27.1 (16.8)
	5th	40.0 (24.9)
Reverse	1st	6.2 (3.9)
		11.9 (7.4)
	3rd	27.1 (16.8)

· This is the maximum travel speed of a standard machine with unfilled bucket.

AXLES

Drive system	Four-wheel drive system
Front	Fixed
Rear	Oscillating ±11 degrees
Hub reduction	Planetary reduction at wheel end
Differential	Hydraulic lock differential(F) / Conventional Type(R)
Reduction ratio	27.0

TIRES

Type	Tubeless, loader design tires
Standard	875/65R29 L3 ★★
Options Include	29.5R25 L3 ★★

BRAKES

Service brakes	Hydraulically actuated, wet disc brakes actuate all 4 wheels, independent axle-by-axle system. Self adjusting & wheel speed brake.
Parking brake	Spring-applied, hydraulically released brake
Emergency brake	When brake oil pressure drops, indicator light alerts operator and parking brake automatically applies.

CABIN

ROPS / FOPS meet ISO 3471 and ISO 3449

HYDRAULIC SYSTEM

Type	Load sensing hydraulic system
Pump	Variable displacement piston pump 520 lpm
Control valve	2 Spool (Bucket, Boom) 3 Spool (Bucket, Boom, Aux)
System Pressure	315 bar (4,569 psi) The valve has four functions; Raise / Hold / Lower / Float
Lift Circuit	Can adjust automatic kickout from horizontal to full lift. The valve has three functions; Tilt back / Hold / Dump
Tilt Circuit	Can adjust automatic bucket positioner to desired load angle.
Cylinder	Type: double acting
	No. of cylinders-bore × stroke
Lift	2-190 × 890 mm (2-7.1" × 2' 10.8")
	Bucket Cylinder 1-210 × 550 mm (1-7.9" × 1' 9.7")
Hydraulic cycle time with rated payload	Raise from Carry Position: 6.1 Sec.
	Dump, at maximum raise: 1.7 Sec.
	Lower, empty, float down: 4.3 Sec. Total: 12.1 Sec.

STEERING SYSTEM

Type	Load sensing hydrostatic articulated steering
Pump	Variable displacement piston pump
System pressure	210 bar (3,046 psi)
Cylinder	Double acting 2 - 105 mm (4.1") x 460 mm (18.1")
Steering angle	40° to both right and left angle, respectively
Features	Center-point frame articulation. Tilt and telescopic steering column.

* Hyundai Bio Hydraulic Oil (HBHO) available

SERVICE REFILL CAPACITIES

Fuel tank	440.0 liters (116.2 US gal)
DEF tank	44.5 liters (11.8 US gal)
Cooling system	45.5 liters (12.0 US gal)
Crankcase	34.0 liters (9.0 US gal)
Transmission	56.2 liters (14.8 US gal)
Front axle	64.0 liters (16.9 US gal)
Rear axle	64.0 liters (16.9 US gal)
Hydraulic tank	200 liters (52.8 US gal)
Hydraulic system (Including tank)	360 liters (95.1 US gal)

SOUND

Guaranteed noise level presented below can be differed depending on a range of factors such as operating condition, speed of a cooling fan, types of engine and so forth. Hearing protection shall be necessary if an operator is working in the improperly maintained cabin or exposed to a noisy environment by leaving doors and/or windows open.

With cooling fan speed at maximum value:

Operator sound pressure level (ISO 6396:2008)	70 dB(A)
Exterior sound power level (ISO 6395:2008)	108 dB(A)

* Distance of 15 m (49.2 ft), moving forward in second gear ratio.

HL985A DIMENSIONS & WORKING RANGE

HL985A DIMENSIONS

All dimensions are approximate.

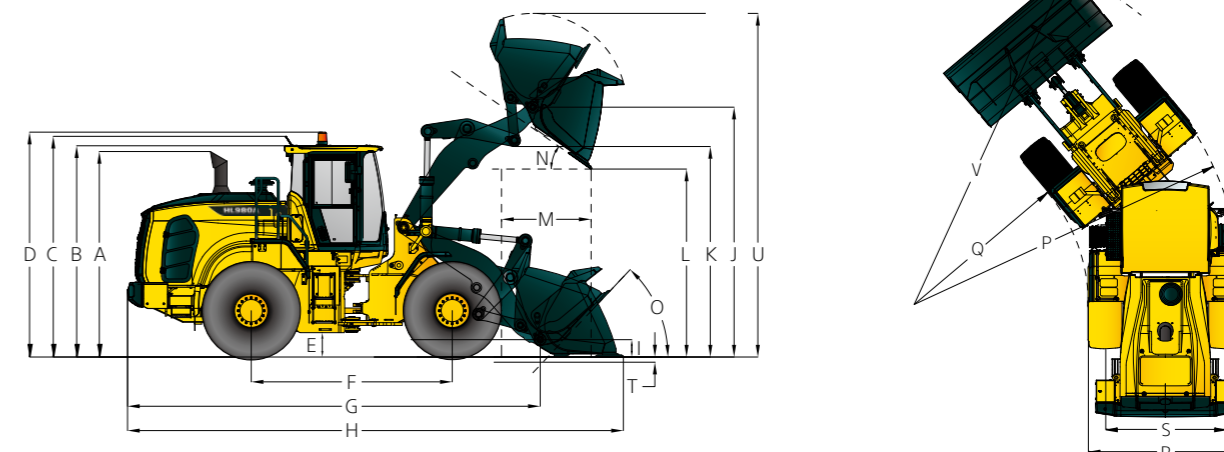

Unit : mm (ftin)

Model		HL985A		
		mm	ft/in	
A	Height to Top of Exhaust Pipe	3,715	12'2"	
B	Height to Top of Cabin	3,865	12'8"	
C	Height to Top of Product Link Antenna	3,905	12'10"	
D	Height to Top of Warning Beacon	3,995	13'1"	
E	Ground clearance	487	1'7"	
F	Wheelbase	3,800	12'6"	
G	Overall Length(without bucket)	8,465	27'9"	
H	Shipping length(with bucket level on ground)	10,000	32'10"	
I	Hinge Pin Height at Carry Position	540	1'9"	
J	Hinge Pin Height at Maximum Lift	4,750	15'7"	
K	Lift Arm Clearance at Maximum lift	4,010	13'2"	
L	Dump Clearance at Maximum lift and 45° Discharge	3,360	11'0"	
M	Reach at Maximum Lift and 45° Discharge	1,550	5'1"	
N	Dump Angle at Maximum Lift and Dump(on stops)	48	-	
O	Roll back Angle	Ground	42	-
		Carry	47	-
P	Clearance Circle(diameter) to Outside of Tires	14,440	47'3"	
Q	Clearance Circle(diameter) to Inside of Tires	7,560	24'10"	
R	Width over Tires(unloaded)	3,420	11'3"	
S	Tread Width	2,540	8'4"	

* T,U,V are indicated on the p.17

STANDARD / OPTION (NORTH AMERICA)

CABIN & INTERIOR	STD
ALARMS, AUDIBLE AND VISUAL	
Air filter clogging	●
Battery voltage	●
Brake oil pressure	●
Engine coolant level	●
Engine oil pressure	●
Fuel level	●
Hydraulic oil temperature	●
Engine coolant temperature	●
Service brake oil pressure	●
Transmission error	●
Transmission oil temperature	●
BATTERIES	
1315 CCA, 12 V, 2 pcs	●
GUAGES	
Engine coolant temperature	●
Fuel level	●
Speedometer	●
Transmission oil temperature	●
INDICATOR LIGHTS	
Parking brake	●
Head light (High beam)	●
Pilot cut off	●
Turning light	●
Seat belt ON/OFF	●
Engine auto stop	●
Clutch Cut Off	●
Ride control	●
Joystick steering	●
FNR	●
Differential Lock	●
LCD DISPLAY (CLUSTER)	
Transmission gear range	●
Parking brake	●
FWD / REV	●
LCD DISPLAY (MONITOR)	
Engine rpm	●
Fuel rate	●
Fault and maintenance warning	●
Odometer	●
Hour meter	●
Horn, electric	●
LIGHTING SYSTEM	
Brake lights (Counterweight)	●
LED beacon light	●
2 stop and tail lights	●
4 turn signals	●
2 Head lights on front tower	●
2 Head lights (LED) on front tower	●
2 Working lights on front roof	●
4 Working lights on front roof	●
2 Working lights on rear roof	●
4 Working lights (LED) on front roof	●
2 Working lights (LED) on rear roof	●
2 Working lights on grill	●
2 Working lights (LED) on grill	●
License light	●

CABIN & INTERIOR	STD
SWITCHES	
Hazard	●
Engine hood open	●
Parking	●
Battery master switch	●
FNR shifter	●
Pilot cut off	●
Differential Lock foot switch	●
Emergency steering	●
IGNITION	
Key	●
Button	●
MEMBRANE SWITCHES IN MONITOR	
Main light	●
Work light	●
Weighing System	●
Mirror heat	●
Auto position	●
Fine modulation	●
Rear wiper	●
Auto grease	●
Ride control	●
Beacon light	●
Cam	●
CABIN (SOUND SUPPRESSED)	
ROPS/ FOPS Cabin	●
Coat hook	●
Rear view mirrors (1 Inside / 2 Outside, heated)	●
Steering column, tilt and telescopic	●
Steering wheel with knob	●
Roller type sunshade (Front window)	●
Roller type sunshade (Rear window)	●
Tinted safety glass	●
Magazine pocket	●
Radio / USB player	●
Wrist rest & Armrest	●
24 V to 12 V DC converter (20 A)	●
DOOR	
Door and cabin locks, one key	●
Doors, service access (Locking)	●
Doors, service access (Remote control)	●
AUTOMATIC CLIMATE CONTROL	
Air conditioner & heater	●
Defroster	●
Intermittent wiper and washer, front and rear	●
SEAT	
2" Retractable seat belt & adjustable mechanical suspension (Heated)	●
3" Retractable seat belt & adjustable air suspension (Heated)	●
2" Retractable seat belt & adjustable air suspension (Heated)	●
PERSONAL STORAGE SPACE	
Console box	●
Cup Holder	●
PEDALS	
One brake pedal	●
Dual-Brake pedal	●

ENGINE	STD
ENGINE	
Cummins X12 Engine	●
POWER TRAIN	
Transmission F5 / R3, computer controlled, electronic soft shift, auto-shift and kick-down features included	●
Torque converter	●
Transmission oil sight level	●
Transmission oil cooler	●
Travel speed limiter (20-40 km/h)	●
FRONT AXLE	
Hydraulic lock differential	●
REAR AXLE	
Conventional Type	●
BRAKE	
Service brake (Enclosed wet-disk)	●
Parking brake	●
TIRES	
29.5R25, L3, ★★	●
875/65R29 L3, ★★	●
HYDRAULIC SYSTEM	
Boom kickout, automatic	●
Bucket positioner, automatic	●
Diagnostic pressure taps	●
Hydraulic oil cooler	●
Hydraulic oil level sight gauge	●
EH Control (Joystick)	●
EH Control (Fingertip)	●
Ride control system	●
Extra piping-for auxiliary function	●
Auto grease system	●
Quick coupler piping	●
SAFETY	
Emergency stop	●
Emergency steering	●
Rear view camera	●
Fire extinguisher	●
OBJECT DETECTION	
AAVM (AVM + IMOD)	●
Radar	●
Secondary Monitor	●
OTHER	
Fuel warmer	●
Articulation locking bar	●
Lift and tie-down hooks	●
Loader linkage, sealed	●
Vandalism protection caplocks	●
E-horn	●
Tool kit	●
Rain cap	●
Pre-cleaner	●
Air compressor	●
Wheel chock	●
BUCKET	
6.5m³ Bolt-On Cutting Edges Type	●
7.0m³ Bolt-On Cutting Edges Type	●
7.0m³ 2-Piece Tooth & Segment Type	●

OTHER	STD
COUNTERWEIGHT	
Counterweight	●
Drawbar with pin	●
ERGONOMICALLY LOCATED AND SLIP RESISTANT, LEFT & RIGHT	
Handrails / Ladders / Platforms / Steps	●
GUARDS	
Cabin (Front / Rear)	●
Fenders (Front / Rear)	●
Under guard (E/G, T/M)	●
Mud guard	●
TELEMETICS	
ECD (Engine connected diagnostics)	●
Hi MATE	●

* Standard and optional equipment may vary. Contact your Hyundai dealer for more information. The machine may vary according to International standards.
 * The photos may include attachments and optional equipment that are not available in your area.
 * Materials and specifications are subject to change without advance notice.
 * All imperial measurements rounded off to the nearest pound or inch.

STANDARD / OPTION (EUROPE)

CABIN & INTERIOR	STD
ALARMS, AUDIBLE AND VISUAL	
Air filter clogging	●
Battery voltage	●
Brake oil pressure	●
Engine coolant level	●
Engine oil pressure	●
Fuel level	●
Hydraulic oil temperature	●
Engine coolant temperature	●
Service brake oil pressure	●
Transmission error	●
Transmission oil temperature	●
BATTERIES	
1315 CCA, 12 V, 2 pcs	●
GUAGES	
Engine coolant temperature	●
Fuel level	●
Speedometer	●
Transmission oil temperature	●
INDICATOR LIGHTS	
Parking brake	●
Head light (High beam)	●
Pilot cut off	●
Turning light	●
Seat belt ON/OFF	●
Engine auto stop	●
Clutch Cut Off	●
Ride control	●
Joystick steering	●
FNR	●
Differential Lock	●
LCD DISPLAY (CLUSTER)	
Transmission gear range	●
Parking brake	●
FWD / REV	●
LCD DISPLAY (MONITOR)	
Engine rpm	●
Fuel rate	●
Fault and maintenance warning	●
Odometer	●
Hour meter	●
Horn, electric	●
LIGHTING SYSTEM	
Brake lights (Counterweight)	●
LED beacon light	●
2 stop and tail lights	●
4 turn signals	●
2 Head lights on front tower	●
2 Head lights (LED) on front tower	●
2 Working lights on front roof	●
4 Working lights on front roof	●
2 Working lights on rear roof	●
4 Working lights (LED) on front roof	●
2 Working lights (LED) on rear roof	●
2 Working lights on grill	●
2 Working lights (LED) on grill	●
License light	●

CABIN & INTERIOR	STD
SWITCHES	
Hazard	●
Engine hood open	●
Parking	●
Battery master switch	●
FNR shifter	●
Pilot cut off	●
Differential Lock foot switch	●
Emergency steering	●
IGNITION	
Key	●
Button	●
MEMBRANE SWITCHES IN MONITOR	
Main light	●
Work light	●
Weighing System	●
Mirror heat	●
Auto position	●
Fine modulation	●
Rear wiper	●
Auto grease	●
Ride control	●
Beacon light	●
Cam	●
CABIN (SOUND SUPPRESSED)	
ROPS/ FOPS Cabin	●
Coat hook	●
Rear view mirrors (1 Inside / 2 Outside, heated)	●
Steering column, tilt and telescopic	●
Steering wheel with knob	●
Roller type sunshade (Front window)	●
Roller type sunshade (Rear window)	●
Tinted safety glass	●
Magazine pocket	●
Radio / USB player	●
Wrist rest & Armrest	●
24 V to 12 V DC converter (20 A)	●
DOOR	
Door and cabin locks, one key	●
Doors, service access (Locking)	●
Doors, service access (Remote control)	●
AUTOMATIC CLIMATE CONTROL	
Air conditioner & heater	●
Defroster	●
Intermittent wiper and washer, front and rear	●
SEAT	
2" Retractable seat belt & adjustable mechanical suspension (Heated)	●
3" Retractable seat belt & adjustable air suspension (Heated)	●
2" Retractable seat belt & adjustable air suspension (Heated)	●
PERSONAL STORAGE SPACE	
Console box	●
Cup Holder	●
PEDALS	
One brake pedal	●
Dual-Brake pedal	●

ENGINE	STD
ENGINE	
Cummins X12 Engine	●
POWER TRAIN	
STD	
Transmission F5 / R3, computer controlled, electronic soft shift, auto-shift and kick-down features included	●
Torque converter	●
Transmission oil sight level	●
Transmission oil cooler	●
Travel speed limiter (20-40 km/h)	●
FRONT AXLE	
Hydraulic lock differential	●
REAR AXLE	
Conventional Type	●
BRAKE	
Service brake (Enclosed wet-disk)	●
Parking brake	●
TIRES	
29.5R25, L3, ★★	●
875/65R29 L3, ★★	●
HYDRAULIC SYSTEM	
STD	
Boom kickout, automatic	●
Bucket positioner, automatic	●
Diagnostic pressure taps	●
Hydraulic oil cooler	●
Hydraulic oil level sight gauge	●
EH Control (Joystick)	●
EH Control (Fingertip)	●
Ride control system	●
Extra piping-for auxiliary function	●
Auto grease system	●
Quick coupler piping	●
SAFETY	
STD	
Emergency stop	●
Emergency steering	●
Rear view camera	●
Fire extinguisher	●
OBJECT DETECTION	
AAVM (AVM + IMOD)	●
Radar	●
Secondary Monitor	●
OTHER	
STD	
Fuel warmer	●
Articulation locking bar	●
Lift and tie-down hooks	●
Loader linkage, sealed	●
Vandalism protection caplocks	●
E-horn	●
Tool kit	●
Rain cap	●
Pre-cleaner	●
Air compressor	●
Wheel chock	●
BUCKET	
6.5m ³ Bolt-On Cutting Edges Type	●
7.0m ³ Bolt-On Cutting Edges Type	●
7.0m ³ 2-Piece Tooth & Segment Type	●

OTHER	STD
COUNTERWEIGHT	
Counterweight	●
Drawbar with pin	●
ERGONOMICALLY LOCATED AND SLIP RESISTANT, LEFT & RIGHT	
Handrails / Ladders / Platforms / Steps	●
GUARDS	
Cabin (Front / Rear)	●
Fenders (Front / Rear)	●
Under guard (E/G, T/M)	●
Mud guard	●
TELEMETICS	
ECD (Engine connected diagnostics)	●
Hi MATE	●

- * Standard and optional equipment may vary. Contact your Hyundai dealer for more information. The machine may vary according to International standards.
- * The photos may include attachments and optional equipment that are not available in your area.
- * Materials and specifications are subject to change without advance notice.
- * All imperial measurements rounded off to the nearest pound or inch.

STANDARD / OPTION (OCEANIA)

CABIN & INTERIOR	STD
ALARMS, AUDIBLE AND VISUAL	
Air filter clogging	●
Battery voltage	●
Brake oil pressure	●
Engine coolant level	●
Engine oil pressure	●
Fuel level	●
Hydraulic oil temperature	●
Engine coolant temperature	●
Service brake oil pressure	●
Transmission error	●
Transmission oil temperature	●
BATTERIES	
1315 CCA, 12 V, 2 pcs	●
GUAGES	
Engine coolant temperature	●
Fuel level	●
Speedometer	●
Transmission oil temperature	●
INDICATOR LIGHTS	
Parking brake	●
Head light (High beam)	●
Pilot cut off	●
Turning light	●
Seat belt ON/OFF	●
Engine auto stop	●
Clutch Cut Off	●
Ride control	●
Joystick steering	●
FNR	●
Differential Lock	●
LCD DISPLAY (CLUSTER)	
Transmission gear range	●
Parking brake	●
FWD / REV	●
LCD DISPLAY (MONITOR)	
Engine rpm	●
Fuel rate	●
Fault and maintenance warning	●
Odometer	●
Hour meter	●
Horn, electric	●
LIGHTING SYSTEM	
Brake lights (Counterweight)	●
LED beacon light	●
2 stop and tail lights	●
4 turn signals	●
2 Head lights on front tower	●
2 Head lights (LED) on front tower	●
2 Working lights on front roof	●
4 Working lights on front roof	●
2 Working lights on rear roof	●
4 Working lights (LED) on front roof	●
2 Working lights (LED) on rear roof	●
2 Working lights on grill	●
2 Working lights (LED) on grill	●
License light	●

CABIN & INTERIOR	STD
SWITCHES	
Hazard	●
Engine hood open	●
Parking	●
Battery master switch	●
FNR shifter	●
Pilot cut off	●
Differential Lock foot switch	●
Emergency steering	●
IGNITION	
Key	●
Button	
MEMBRANE SWITCHES IN MONITOR	
Main light	●
Work light	●
Weighing System	●
Mirror heat	●
Auto position	●
Fine modulation	●
Rear wiper	●
Auto grease	●
Ride control	●
Beacon light	●
Cam	●
CABIN (SOUND SUPPRESSED)	
ROPS/ FOPS Cabin	●
Coat hook	●
Rear view mirrors (1 Inside / 2 Outside, heated)	●
Steering column, tilt and telescopic	●
Steering wheel with knob	●
Roller type sunshade (Front window)	●
Roller type sunshade (Rear window)	●
Tinted safety glass	●
Magazine pocket	●
Radio / USB player	●
Wrist rest & Armrest	●
24 V to 12 V DC converter (20 A)	●
DOOR	
Door and cabin locks, one key	●
Doors, service access (Locking)	●
Doors, service access (Remote control)	●
AUTOMATIC CLIMATE CONTROL	
Air conditioner & heater	●
Defroster	●
Intermittent wiper and washer, front and rear	●
SEAT	
2" Retractable seat belt & adjustable mechanical suspension (Heated)	●
3" Retractable seat belt & adjustable air suspension (Heated)	●
2" Retractable seat belt & adjustable air suspension (Heated)	●
PERSONAL STORAGE SPACE	
Console box	●
Cup Holder	●
PEDALS	
One brake pedal	●
Dual-Brake pedal	●

ENGINE	STD
ENGINE	
Cummins X12 Engine	●
POWER TRAIN	STD
Transmission F5 / R3, computer controlled, electronic soft shift, auto-shift and kick-down features included	●
Torque converter	●
Transmission oil sight level	●
Transmission oil cooler	●
Travel speed limiter (20-40 km/h)	●
FRONT AXLE	
Hydraulic lock differential	●
REAR AXLE	
Conventional Type	●
BRAKE	
Service brake (Enclosed wet-disk)	●
Parking brake	●
TIRES	
29.5R25, L3, ★★	●
875/65R29 L3, ★★	●
HYDRAULIC SYSTEM	STD
Boom kickout, automatic	●
Bucket positioner, automatic	●
Diagnostic pressure taps	●
Hydraulic oil cooler	●
Hydraulic oil level sight gauge	●
EH Control (Joystick)	●
EH Control (Fingertip)	●
Ride control system	●
Extra piping-for auxiliary function	●
Auto grease system	●
Quick coupler piping	●
SAFETY	STD
Emergency stop	●
Emergency steering	●
Rear view camera	●
Fire extinguisher	●
OBJECT DETECTION	
AAVM (AVM + IMOD)	●
Radar	●
Secondary Monitor	●
OTHER	STD
Fuel warmer	●
Articulation locking bar	●
Lift and tie-down hooks	●
Loader linkage, sealed	●
Vandalism protection caplocks	●
E-horn	●
Tool kit	●
Rain cap	●
Pre-cleaner	●
Air compressor	●
Wheel chock	●
BUCKET	
6.5m ³ Bolt-On Cutting Edges Type	●
7.0m ³ Bolt-On Cutting Edges Type	●
7.0m ³ 2-Piece Tooth & Segment Type	●

OTHER	STD
COUNTERWEIGHT	
Counterweight	●
Drawbar with pin	●
ERGONOMICALLY LOCATED AND SLIP RESISTANT, LEFT & RIGHT	
Handrails / Ladders / Platforms / Steps	●
GUARDS	
Cabin (Front / Rear)	●
Fenders (Front / Rear)	●
Under guard (E/G, T/M)	●
Mud guard	●
TELEMETICS	
ECD (Engine connected diagnostics)	●
Hi MATE	●

- * Standard and optional equipment may vary. Contact your Hyundai dealer for more information. The machine may vary according to International standards.
- * The photos may include attachments and optional equipment that are not available in your area.
- * Materials and specifications are subject to change without advance notice.
- * All imperial measurements rounded off to the nearest pound or inch.