

HX330A L

With EU Stage V Engine Installed

* Photo may include optional equipment.



Head Office(Sales Office)
14F, GLOBAL R&D CENTER, 477 BUNDANG SUSEO-RO, BUNDANG-GU, SEONGNAM-SI, GYEONGGI-DO, 13553, KOREA

PLEASE CONTACT

Gross Power
310 HP (231 kW) at 2,100 rpm

Net Power
304 HP (227 kW) at 2,100 rpm

Bucket Capacity
1.44 ~ 2.10 m³

Operating Weight
33,750 kg / 74,406 lb

WHAT'S NEWEST AND BEST

HX330AL

THE BEST PRODUCTIVITY AND FUEL EFFICIENCY

- EU STAGE V Engine **NEW**
- Eco Report **NEW**
- IPC (Intelligent Power Control) **Upgrade**
- Fuel Rate Information
- Eco Gauge
- Automatic Engine Shutdown

EASY CONTROL AND COMFORTABLE OPERATION

- Visibility and Handle Improvement **NEW**
- Key On Init Work Mode **NEW**
- One Pedal Travel Straight **Option**
- Proportional Auxiliary Hydraulic System **Option**
- Intelligent & Wide Cluster
- Jog Dial Module
- OME (Owner Menu Editing)

NEW EXTERIOR DESIGN FOR ROBUSTNESS AND SAFETY

- Side Protector **Option**
- ROPS
FOG/FOPS **Option**
- Reinforced Durability of Upper and Lower Structure
and Attachments
- Durable Cooling Module
- Reinforced Pin, Bush and Polymer Shim
- Wear Resistant Cover Plate

THE ULTIMATE SAFE ENVIRONMENT

- Auto Safety Lock **NEW**
- AAVM **Option**
- Seatbelt Warning Alarm
- Cabin Suspension Mount

SERVICEABILITY AND TELEMATICS

- ECD (Engine Connected Diagnostics) **NEW**
- Hi MATE **Option**
- 2x Longer Lasting Filter (1000hr)
- Unnecessary Regular DPF Cleaning
Service Interval
- Mobile Fleet App.
- Connected Diagnostics

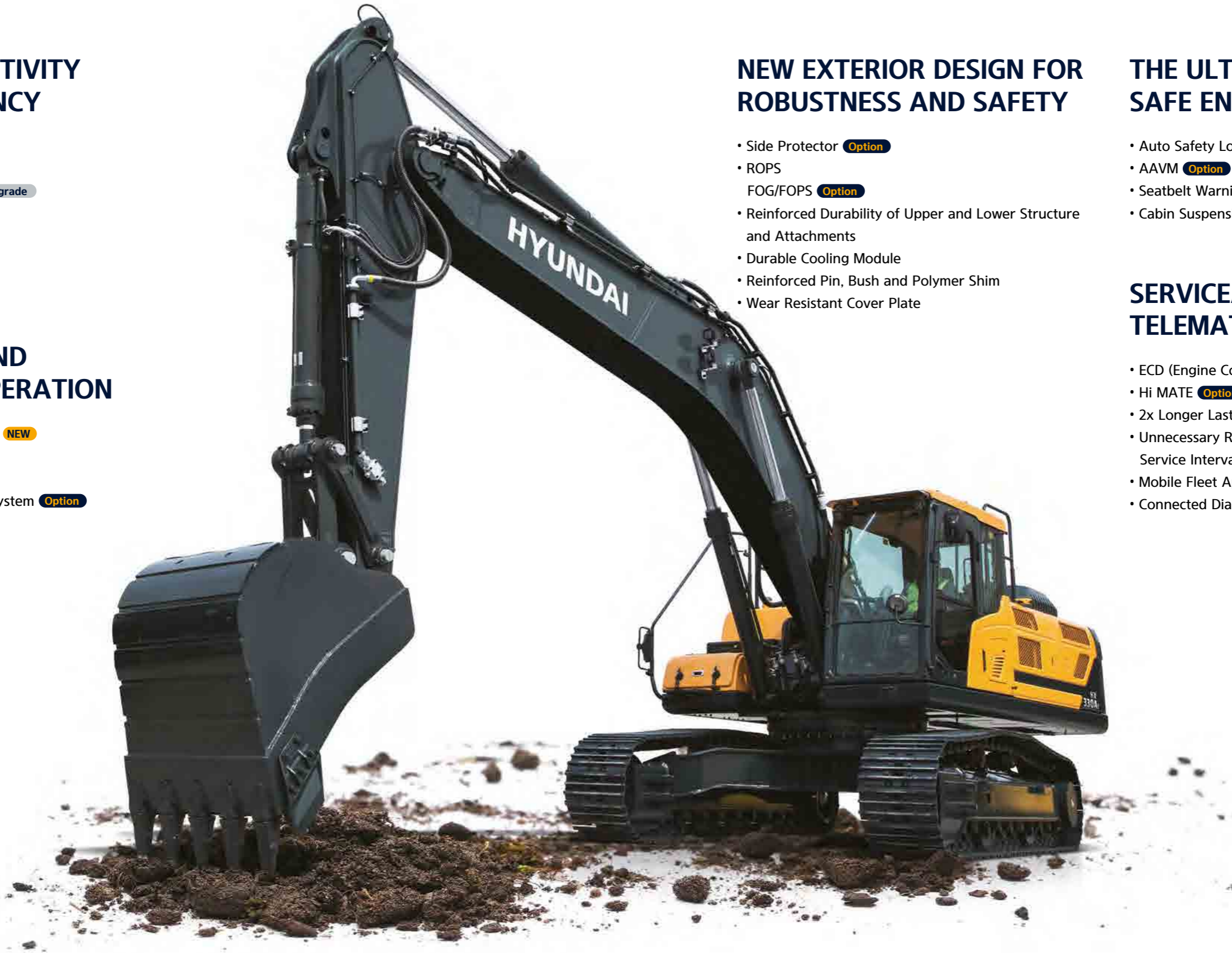

* Photo may include optional equipment.

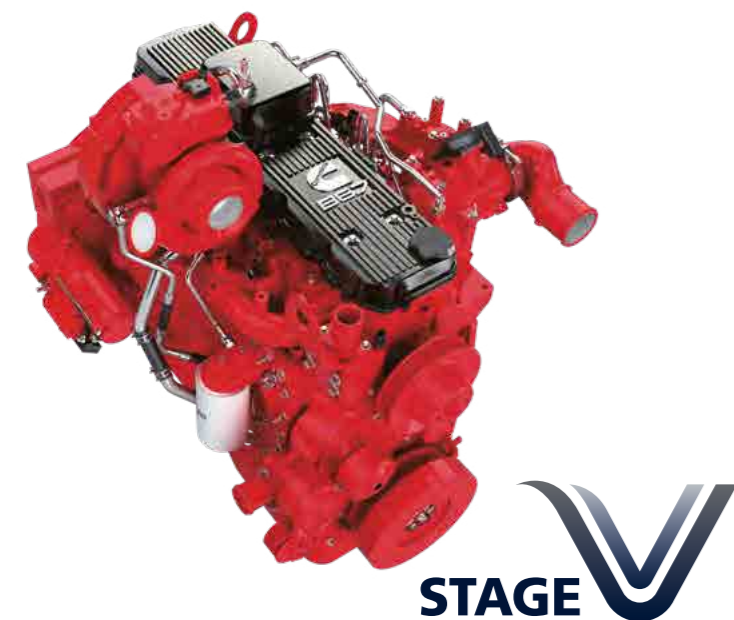

EU STAGE V CERTIFIED ENGINE

Cummins L9 engine is satisfying the most strict environmental emission regulation in the world (Reduction in PM 60%)

EU STAGE V Engine **NEW**

Now in its fourth decade of continuous improvement, the L9 for 2019 features an EGR-free design that delivers 5 percent more power and 7 percent more peak torque than the current model. Increased fuel economy and longer maintenance intervals contribute to a reduced cost of operation.

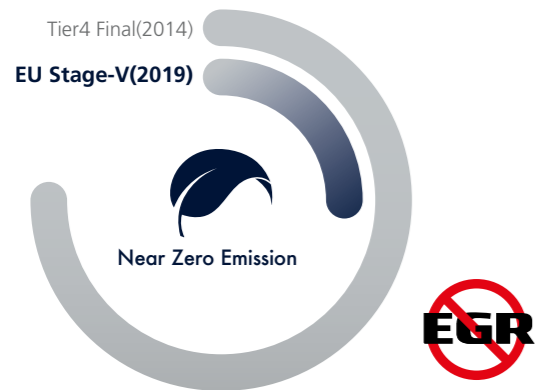

IPC (Intelligent Power Control) **Upgrade**

HX A Series adopts the upgraded IPC system. It is able to optimize pump flow rate and power at the various working condition through the individual pump control. Furthermore, optimized design of MCV and pipe line minimizes energy loss such as conflux and throttle loss.



ENVIRONMENTALLY FRIENDLY FUEL EFFICIENCY

Eco Report **NEW**

It reports the excavator's inefficient operation status and help improving operator's working habit.



Fuel Rate Information

Fuel information is displayed as average rate and latest fuel consumed for guiding to economy operating.



Eco Gauge

Gauge level changes in accordance with engine working load and color indicates fuel saving-operation status.



Automatic Engine Shutdown

Adjustable 'Automatic Engine Shutdown' significantly reduces idle time, overall operating hours and fuel consumption.



THE BEST PRODUCTIVITY AND FUEL EFFICIENCY

HX A Series is equipped with eco-friendly, high-performance engines that meet the EU Stage V emission requirements.



MORE FUEL-EFFICIENCY
(Compared to HX series)

Leveling **8%**

Truck Loading **4%**

Photo may require optional equipment.



We make the best performance in rough working conditions without any unsureness with trustworthy HX330AL.



HX A Series is equipment with eco-friendly, high-performance engines that meet the EU Stage V emission requirement. Become a true leader on the ground with HX A Series.

ROPS / FOG Cabin

The cabin structure of Hyundai HX A Series is using integrally welded low-stress, high strength steel to meet ROPS and FOG certification.

- ROPS : Roll-Over Protective Structures ISO12117-2
- FOG : Falling Object Guard, ISO10262 Level2



Reinforced Durability of Upper and Lower Structure and Attachments

The upper and lower structure and attachments of HX A Series have higher durability than demanded on the site, as proven through numerous tests including road tests and virtual simulation. The wear resistance of the bucket has been improved by use of new material.

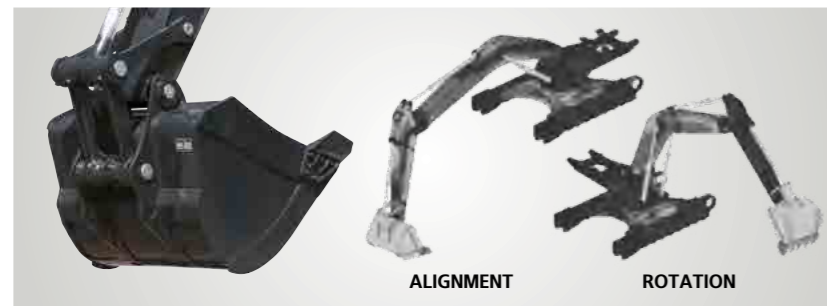

Durable Cooling Module

HX A Series has a durable cooling module that passed stringent tests, demonstrating the highest productivity in tough working environments.



Side Protector Option

Protect sides frame during operation in narrow area

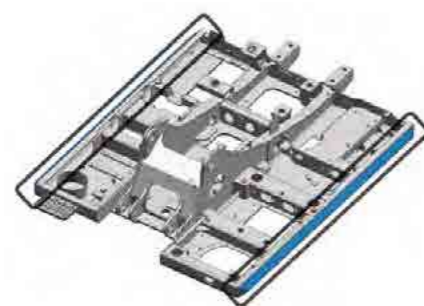

NEW EXTERIOR DESIGN FOR ROBUSTNESS AND SAFETY

The true value of HX A Series lies in its durability and high productivity. The robust upper and lower frame structure can endure external shock and heavy work loads. Attachment performance has been proven through rigorous field testing. No matter how tough the working environment is, you can always rely on the HYUNDAI Excavator HX A Series.



1 Reinforced Pin, Bush and Polymer Sahim

2 Wear Resistant Cover Plate

* Photo may include optional equipment.

13%

CABIN SPACE FOR DRIVERS INCREASED BY



310mm
340mm

HYUNDAI

EASY CONTROL AND COMFORTABLE OPERATION

Many electronic functions are concentrated in the most convenient spot for operators to improve work efficiency. The highly-advanced infotainment system, a product of HCE's intensive information technology development, enables both productivity and comfort while working! HX A Series is designed with the operator in mind.

Intelligent & Wide Cluster

The 8" capacitive-type display (like smart-phone display) of HX A Series is delivering excellent legibility. The centralized switches on the display allow convenience of checking the urea level and temperature outside the cabin.

One Pedal Travel Straight Option

One Pedal straight Travel is available for customers' convenience when long distance traveling or combination of attachment work with traveling is necessary.



Proportional Auxiliary Hydraulic System Option

Proportional control switch with better speed control helps operators to enlarge the operation convenience whenever they do time-consuming work. Newly added detent function allows an operator to continue using 2 way piping flow even if the operator does not keep pressing proportional control switch.

Jog Dial Module

The integrated jog dial module applies to the accelerator, remote air conditioner controller and operation of the cluster, allowing convenient operation. In the event of failure of the jog dial module, the emergency mode is activated on the cluster to ensure fail-safe function.



Visibility and Handle Improvement NEW

Visibility through cabin door is improved and handle design on the cabin door is also improved and offers better convenient while operator get on and off the cabin.



Key On Init Work Mode NEW

Operator can maintain previously set about attachment mode when starting.



OME (Owner Menu Editing)

The Owner of machine can restrict operators access the set of functions. In the menu, Owner can set the list of the function to lock or unlock it. It is necessary to input the password to access the set of function.



// HX330AL with advanced technology ensures our safety on a construction site. //



HX A Series excavators are products of HCE's spirit of initiative, creativity, and strong drive. HCE engineers, who are the best in the industry, have worked tirelessly to offer a zero-defect product. The new HX A Series reflects customers' needs in the field gleaned by thorough monitoring.

Auto Safety Lock **NEW**

It prevents unintended operation. If operator unlock safety lever when RCV lever is pressed, excavator is not controlled by RCV lever.

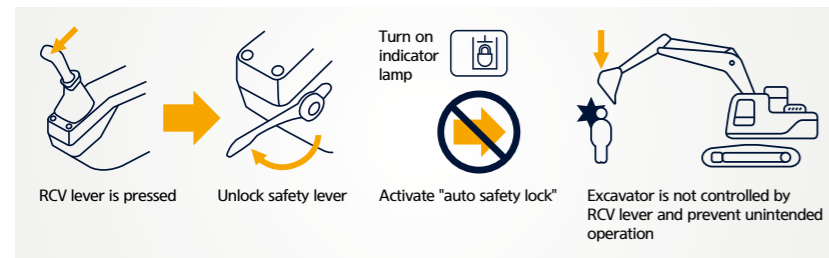

AAVM(Advanced Around View Monitoring) Camera System **Option**

HX A Series has a state-of-the-art AAVM video camera system to secure field of vision for operators in all directions, thereby preventing accidents. Operators can easily check the workplace in the front and rear and to the right and left.

- **AAVM**(Advanced Around View Monitoring) : Secure field of vision in all directions by nine views including 3D bird's eye view and 2D/4CH view.
- **IMOD**(Intelligent Moving Object Detection) : Inform when people or dangerous objects are detected within the range of operation(recognition distance : 5 m).



Seatbelt Warning Alarm

If the seatbelt is not buckled when the ignition key is turned, an alarm is triggered in intervals along with a continuous visual alert. This emphasises our priority for operator safety.

Cabin Suspension Mount

With a low-vibration design by the coil spring and damper inside the mount, the cab suspension mount of HX A Series reduces noise inside the cabin and improves durability, providing a comfortable operation space that lessens operators' fatigue.



THE ULTIMATE SAFE ENVIRONMENT

The true value of HX A Series lies in its durability. The robust frame structure and the attachments show the real value of HX A Series in tough working environments and promise higher productivity.

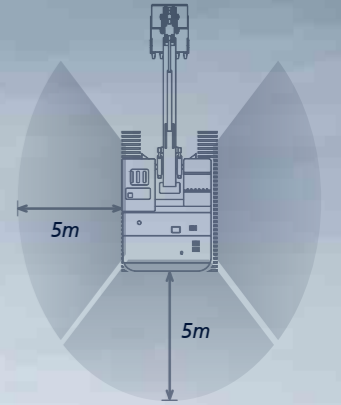

▼
**OBJECT
DETECTION**



SERVICEABILITY AND TELEMATICS

IoT / ICT / AI-based digital technology.
Creating a smart construction site. Maximizes connectivity, productivity, and safety for successful businesses.



Hi MATE

Option

IT'S CONVENIENT, EASY AND VALUABLE

Hi MATE Hyundai's newly developed remote management system, utilizes GPS-satellite technology to provide customers with the highest level of service and product support available. Hi MATE enables users to remotely evaluate machine performance, access diagnostic information, and verify machine locations at the touch of a button.

WHAT IS BENEFITS



Increase Productivity

It helps you operate machines in efficient. You can check the difference between total engine hours and actual working hours. See how productive your machines are and plan any required cost saving solutions. Hi MATE offers working information such as working / idling hours, fuel consumption and rate.



Convenient and Easy Monitoring

There is nothing much to do to monitor your machines. Just log on to the Hi MATE website or mobile application. Hi MATE allows you to watch your machines whenever and wherever you are.



Security

Protect your machines from theft or unauthorized usage with Hi MATE. If the machine moves out of the Geofence boundary, you will get alerts.

ECD(Engine Connected Diagnostics) **NEW**

It supports service technician with remote diagnostics report and ensure it arrive on site with proper tools after preparing in advance.

We are all connected

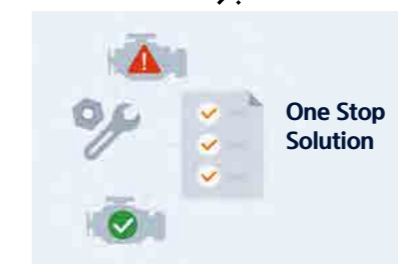

One Stop Solution



Just in 5 Minutes

From fault generation to report

2x Longer Lasting Filter (1,000hr)

The service interval of engine-oil, engine-oil filter and fuel filters have been increased from 500 hours to 1,000 hours



Unnecessary Regular DPF Cleaning Service Interval

Regular ash cleaning for DPF is not necessary, only needed as indicated by fault-indicator lamp.

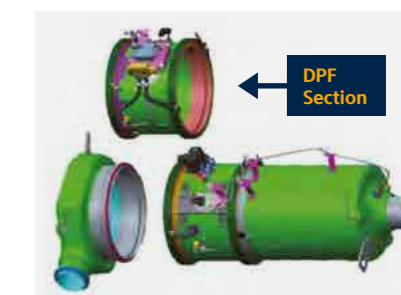

Mobile Fleet App.

The new Mobile App is optimized to fleet management. It provides productivity, health insights based on telematics technology and enables fleet owner just focus on most wanted equipment in view of economical usage, utilization, fault codes and maintenance. The new Mobile App sorts equipment in order of eco-index, utilization-index and fault code level automatically so that urgent equipment pops up automatically.



Hi-MATE Fleet App

HCE-DT AIR App

Connected Diagnostics

HCE-DT Air connect you and your equipment wirelessly via smartphone and laptop right on site. You can diagnose root causes and troubleshoot for fault codes through the connection. Engine connected diagnostics is a kind of cooperated remote diagnostics service between Cummins cloud and Hi MATE cloud. It enables you get engine diagnostics report by cloud based fault code analysis in real-time and prepare parts, tools necessary in advance. It will help increase first visit fix rates.

*Photo may include optional equipment.

SPECIFICATIONS

ENGINE

Maker / Model	Cummins L9
Type	Turbocharged, Charge air cooled, Diesel engine
Gross Power (SAE J1995)	310 HP (231 kW) at 2,100 rpm
Net Power (SAE J1349)	304 HP (227 kW) at 2,100 rpm
Max. Power	325 HP (242 kW) at 1,800 rpm
Peak Torque	1,526 N · m (1126 lb · ft) at 1,400 rpm
Displacement	8,900 cc (543 cu in)

HYDRAULIC SYSTEM

MAIN PUMP	
Type	Variable displacement piston pumps
Max. Flow	2×297.5 l/min (78.6 US gpm 65.4 UK gpm)
Sub-Pump For Pilot Circuit	Gear pump

Cross-sensing and fuel saving pump system

HYDRAULIC MOTORS

Travel	Two speed axial piston motor
Swing	Axial piston motor

RELIEF VALVE SETTING

Implement Circuits	350 kgf/cm ² (4,980 psi)
Travel	350 kgf/cm ² (4,980 psi)
Power Boost (Boom, Arm, Bucket)	380 kgf/cm ² (5,400 psi)
Swing Circuit	300 kgf/cm ² (4,270 psi)
Pilot Circuit	40 kgf/cm ² (569 psi)
Service Valve	Installed

HYDRAULIC CYLINDERS

No. of Cylinder Bore X Stroke	Boom: Ø150×1,480 ST
	Arm: Ø160×1,685 ST
	Bucket: Ø140×1,285 ST

* Hyundai Bio Hydraulic Oil (HBHO) available.

DRIVES & BRAKES

Drive Method	Fully hydrostatic type
Drive Motor	Axial piston motor, in-shoe design
Reduction System	Planetary reduction gear
Max. Drawbar Pull	27,404 kgf (60,415 lbf)
Max. Travel Speed (High / Low)	6.4 km/hr (3.98 mph) / 3.5 km/hr (2.17 mph)
Gradeability	35° (70%)
Parking Brake	Multi wet disc

CONTROL

Pilot pressure operated joysticks and pedals with detachable lever provide almost effortless and fatigueless operation.

Pilot Control	Two joysticks with one safety lever (LH): Swing and arm, (RH): Boom and bucket (ISO)
Traveling And Steering	Two levers with pedals
Engine Throttle	Electric, Dial type

SWING SYSTEM

Swing Motor	Fixed displacement axial piston motor
Swing Reduction	Planetary reduction gear
Swing Bearing Lubrication	Grease-bathed
Swing Brake	Multi wet disc
Swing Speed	10.2 rpm

COOLANT & LUBRICANT CAPACITY

	liter	US gal	UK gal
Fuel Tank	600	158.5	131.9
Engine Coolant	55	14.5	12.1
Engine Oil	30	7.9	6.6
Swing Device	11	2.9	2.42
Final Drive (Each)	7.8	2.1	1.72
Hydraulic System (Including Tank)	414	109.4	91.06
Hydraulic Tank	210	55.5	46.2
DEF/AdBlue	70	18.5	15.4

UNDERCARRIAGE

The X-leg type center frame is integrally welded with reinforced box-section track frames. The undercarriage includes lubricated rollers, idlers, track adjusters with shock absorbing springs and sprockets, and a track chain with double or triple grouser shoes.

Center Frame	X - leg type
Track Frame	Pentagonal box type
No. of Shoes on Each Side	48 EA
No. of Carrier Roller on Each Side	2 EA
No. of Track Roller on Each Side	9 EA
No. of Rail Guard on Each Side	2 EA

OPERATING WEIGHT (APPROXIMATE)

Operating weight, including 6,450mm(21' 2") boom, 3,200mm(10' 6") arm, SAE heaped 1.44 m³(1.88 yd³) bucket, lubricant, coolant, full fuel tank, full hydraulic tank, and all standard equipments.

OPERATING WEIGHT

Shoes	Width mm (in)	Operating Weight		Ground Pressure
		kg (lb)	kgf/cm ² (psi)	
Triple Grouser	600 (24")	HX330AL	33,750(74,406)	0.65 (9.22)
		HX330A NL	33,470 (73,790)	0.64 (9.16)
	700 (28")	HX330AL	34,270 (75,550)	0.57 (8.04)
		HX330AL	34,650 (76,390)	0.50 (7.11)
800 (32")	HX330AL	34,650 (76,390)	0.50 (7.11)	
	HX330AL	35,040 (77,250)	0.45 (6.39)	
900 (36")	HX330AL	35,040 (77,250)	0.45 (6.39)	
	HX330AL	35,040 (77,250)	0.45 (6.39)	
Double Grouser	700 (28")	HX330A HW	37,800 (83,330)	0.62 (8.85)

AIR CONDITIONING SYSTEM

The air condition system for the machine contains the fluorinated greenhouse gas with global warming potential of R134a. (Global Warming Potential : 1430)
The system hold 0.75kg refrigerant consisting of a CO₂ equivalent 1.07kg metric tonne. For more information, Please refer to the manual.

DIMENSION & WORKING RANGE

HX330AL / HX330A NL DIMENSIONS

6.45m (21' 2"), 6.15m (20' 2") BOOM and 2.2m (7' 3"), 2.5m (8' 2"), 3.2m (10' 6"), 4.05m (13' 3") ARM

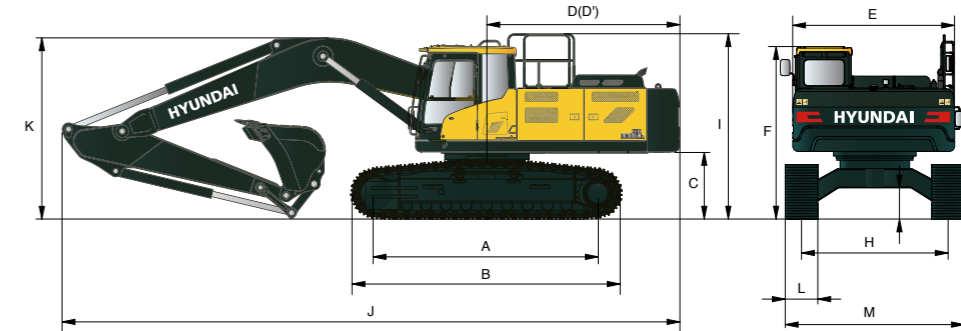

Unit : mm (ft · in)

A Tumbler Distance	4,030 (13' 3")
*B Overall Length of Crawler	4,946 (16' 3")
C Ground Clearance of Counterweight	1,200 (3' 11")
D Tail Swing Radius	3,570 (11' 7")
D' Rear-end Length	3,505 (11' 5")
E Overall width of Upperstructure	2,980 (9' 9")
F Overall Height of Cab	3,145 (10' 4")
G Min. Ground Clearance	500 (1' 8")
H Track Gauge	HX330AL 2,680 (8' 10")
	HX330A NL 2,390 (7' 10")
I Overall Height of Guardrail w/ grouser	3,350 (11' 0")

		6,150 (20' 2")		6,450 (21' 2")			
Boom Length		6,150 (20' 2")		6,450 (21' 2")			
Arm Length		2,200 (7' 3")	2,200 (7' 3")	2,500 (8' 2")	3,200 (10' 6")	4,050 (13' 3")	
	J Overall Length	11,160 (36' 7")	11,460 (37' 7")	11,340 (37' 2")	11,220 (36' 10")	11,200 (36' 9")	
	K Overall Height of Boom	3,670 (12' 0")	3,630 (11' 11")	3,540 (11' 7")	3,360 (11' 0")	3,880 (12' 9")	
	L Track Shoe Width		600 (24")	700 (28")	800 (32")	900 (36")	
		M Overall Width (w/o Extended Foot Board)	HX330AL	3,280 (10' 9")	3,380 (11' 1")	3,480 (11' 5")	3,580 (11' 9")
HX330A NL			2,990 (9' 10")	-	-	-	

* This figure includes the size of grousers.

HX330AL / HX330A NL WORKING RANGE

Unit : mm (ft · in)

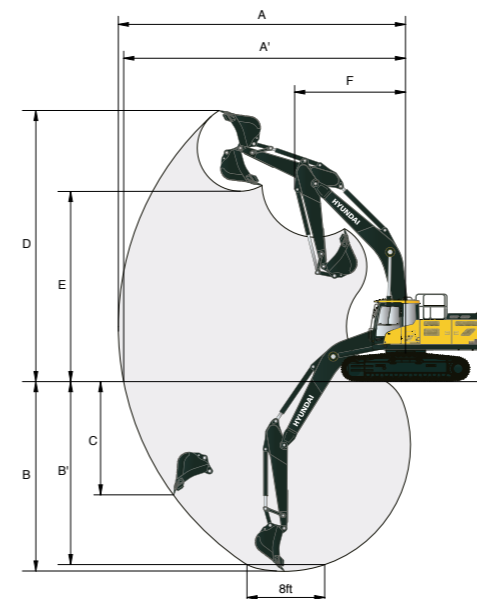

		6,150 (20' 2")		6,450 (21' 2")		
Boom Length		6,150 (20' 2")		6,450 (21' 2")		
Arm Length		2,200 (7' 3")	2,200 (7' 3")	2,500 (8' 2")	3,200 (10' 6")	4,050 (13' 3")
A Max. Digging Reach		10,020 (32' 10")	10,330 (33' 11")	10,500 (34' 5")	11,150 (36' 7")	11,950 (39' 2")
	A' Max. Digging Reach on Ground	9,810 (32' 2")	10,120 (33' 2")	10,290 (33' 9")	10,950 (35' 11")	11,770 (38' 7")
B Max. Digging Depth		6,150 (20' 2")	6,360 (20' 10")	6,660 (21' 10")	7,360 (24' 2")	8,210 (26' 11")
	B' Max. Digging Depth (8' Level)	5,950 (19' 6")	6,170 (20' 3")	6,450 (21' 2")	7,200 (23' 7")	8,080 (26' 6")
C Max. Vertical Wall Digging Depth		5,700 (18' 8")	5,970 (19' 7")	5,660 (18' 7")	6,330 (20' 9")	7,240 (23' 9")
D Max. Digging Height		9,980 (32' 9")	10,260 (33' 8")	10,050 (33' 0")	10,360 (34' 0")	10,780 (35' 4")
E Max. Dumping Height		6,790 (22' 3")	7,060 (23' 2")	6,950 (22' 10")	7,260 (23' 10")	7,670 (25' 2")
F Min. Swing Radius		4,450 (14' 7")	4,630 (15' 2")	4,440 (14' 7")	4,360 (14' 4")	4,290 (14' 1")

DIMENSION & WORKING RANGE

HX330AL HIGH WALKER DIMENSIONS

6.45m (21' 2"), 6.15m (20' 2") BOOM and 2.2m (7' 3"), 2.5m (8' 2"), 3.2m (10' 6"), 4.05m (13' 3") ARM

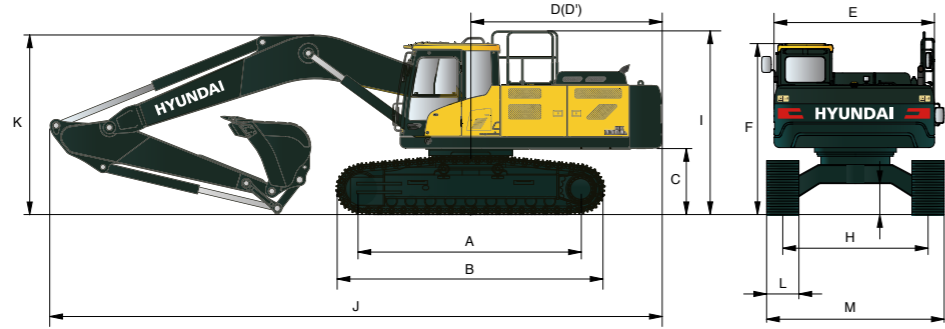

Unit : mm (ft · in)

A Tumbler Distance	4,030 (13' 3")
*B Overall Length of Crawler	5,010 (16' 5")
C Ground Clearance of Counterweight	1,535 (5' 0")
D Tail Swing Radius	3,570 (11' 7")
D' Rear-end Length	3,505 (11' 5")
E Overall width of Upperstructure	2,980 (9' 9")
F Overall Height of Cab	3,480 (11' 5")
G Min. Ground Clearance	800 (2' 7")
H Track Gauge	2,870 (9' 5")
I Overall Height of Guardrail	3,650 (12' 0")

Boom Length	6,150 (20' 2")	6,450 (21' 2")			
Arm Length	2,200 (7' 3")	2,200 (7' 3")	2,500 (8' 2")	3,200 (10' 6")	4,050 (13' 3")
J Overall Length	11,150 (36' 7")	11,460 (37' 7")	11,320 (37' 2")	11,160 (36' 7")	11,240 (36' 11")
K Overall Height of Boom	3,790 (12' 5")	3,720 (12' 2")	3,610 (11' 10")	3,410 (11' 2")	3,800 (12' 6")
L Track Shoe	Type	Double grouser			
	Width	700 (28")			
M Overall width	3,570 (11' 9")				

* This figure includes the size of grousers.

HX330AL HIGH WALKER WORKING RANGE

Unit : mm (ft · in)

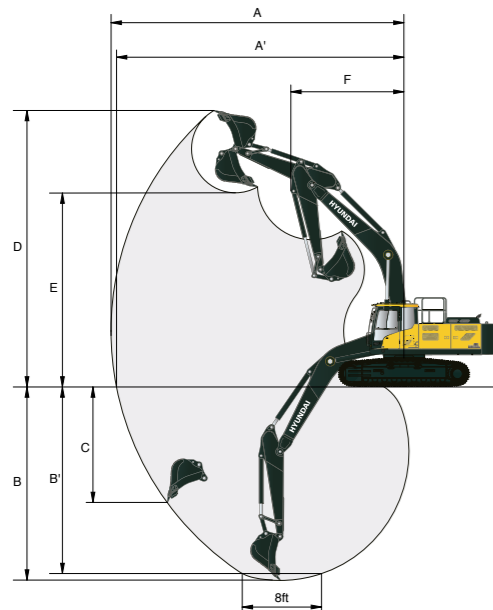

Boom Length	6,150 (20' 2")	6,450 (21' 2")			
Arm Length	2,200 (7' 3")	2,200 (7' 3")	2,500 (8' 2")	3,200 (10' 6")	4,050 (13' 3")
A Max. Digging Reach	10,020 (32' 10")	10,330 (33' 11")	10,500 (34' 5")	11,150 (36' 7")	11,950 (39' 2")
A' Max. Digging Reach on Ground	9,810 (32' 2")	10,120 (33' 2")	10,290 (33' 9")	10,950 (35' 11")	11,770 (38' 7")
B Max. Digging Depth	5,850 (19' 2")	6,060 (19' 11")	6,360 (20' 10")	7,060 (23' 2")	7,910 (25' 11")
B' Max. Digging Depth (8' Level)	5,650 (18' 6")	5,860 (19' 3")	6,140 (20' 2")	6,890 (22' 7")	7,780 (25' 6")
C Max. Vertical Wall Digging Depth	5,400 (17' 9")	5,670 (18' 7")	5,360 (17' 7")	6,030 (19' 9")	6,940 (22' 9")
D Max. Digging Height	10,280 (33' 9")	10,560 (34' 8")	10,350 (33' 11")	10,670 (35' 0")	11,080 (36' 4")
E Max. Dumping Height	7,090 (23' 3")	7,370 (24' 2")	7,250 (23' 9")	7,570 (24' 10")	7,970 (26' 2")
F Min. Swing Radius	4,450 (14' 7")	4,630 (15' 2")	4,440 (14' 7")	4,360 (14' 4")	4,290 (14' 1")

LIFTING CAPACITY

Rating over-front Rating over-side or 360 degree

HX330AL

6.45m (21' 2") boom, 3.2m (10' 6") arm equipped with 600mm (24") triple grouser shoe.

Lift-point height (m/ft)		Lift-point radius								At max. reach				
		3.0m (9.8ft)		4.5m (14.8ft)		6.0m (19.7ft)		7.5m (24.6ft)		9.0m (29.5ft)		Capacity	Reach	
													m(ft)	
7.5m	kg													
24.6ft	lb													
6.0m	kg													
19.7ft	lb													
4.5m	kg			*12,020	*12,020	*9,700	*9,700	*8,550	7,020	*6,670	5,230	*5,450	5,070	9.17
14.8ft	lb			*26,500	*26,500	*21,380	*21,380	*18,850	15,480	*14,700	11,530	*12,020	11,180	(30.1)
3.0m	kg			*15,600	14,270	*11,400	9,360	*9,430	6,750	7,640	5,120	*5,650	4,740	9.44
9.8ft	lb			*34,390	31,460	*25,130	20,640	*20,790	14,880	16,840	11,290	*12,460	10,450	(31.0)
1.5m	kg			*17,450	13,410	*12,910	8,910	9,860	6,500	7,500	4,990	*6,050	4,630	9.47
4.9ft	lb			*38,470	29,560	*28,460	19,640	21,740	14,330	16,530	11,000	*13,340	10,210	(31.1)
Ground	kg			*17,260	13,060	13,540	8,620	9,660	6,320	7,410	4,900	*6,720	4,720	9.25
Line	lb			*38,050	28,790	29,850	19,000	21,300	13,930	16,340	10,800	*14,820	10,410	(30.4)
-1.5m	kg	*10,800	*10,800	*18,990	13,000	13,410	8,500	9,570	6,240			7,670	5,070	8.77
-4.9ft	lb	*23,810	*23,810	*41,870	28,660	29,560	18,740	21,100	13,760			16,910	11,180	(28.8)
-3.0m	kg	*17,470	*17,470	*17,780	13,120	*13,420	8,540	9,630	6,290			8,840	5,820	7.98
-9.8ft	lb	*38,510	*38,510	*39,200	28,920	*29,590	18,830	21,230	13,870			19,490	12,830	(26.2)
-4.5m	kg	*20,720	*20,720	*15,280	13,430	*11,480	8,760					*9,660	7,470	6.76
-14.8ft	lb	*45,680	*45,680	*33,690	29,610	*25,310	19,310					*21,300	16,470	(22.2)
-6.0m	kg													
-19.7ft	lb													

- 1 | Lifting capacity are based on ISO 10567.
- 2 | Lifting capacity of HX Series does not exceed 75% of tipping load with the machine on firm, level ground or 87% of full hydraulic capacity.
- 3 | The Lift-point is bucket pivot mounting pin on the arm(without bucket mass).
- 4 | (*) indicates load limited by hydraulic capacity.

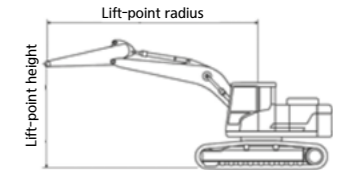

LIFTING CAPACITY

Rating over-front Rating over-side or 360 degree

HX330AL

6.45m (21' 2") boom, 4.05m (13' 3") arm equipped with 600mm (24") triple grouser shoe.

Lift-point height (m/ft)	Lift-point radius										At max. reach					
	1.5m (4.9ft)		3.0m (9.8ft)		4.5m (14.8ft)		6.0m (19.7ft)		7.5m (24.6ft)		9.0m (29.5ft)		Capacity		Reach	
															m(ft)	
9.0m 29.5ft	kg									*4,720	*4,720			*4,530	*4,530	7.55
	lb									*10,410	*10,410			*9,990	*9,990	(24.8)
7.5m 24.6ft	kg													*4,200	*4,200	8.72
	lb													*9,260	*9,260	(28.6)
6.0m 19.7ft	kg									*6,840	*6,840	*5,820	5,240	*4,070	*4,070	9.50
	lb									*15,080	*15,080	*12,830	11,550	*8,970	*8,970	(31.2)
4.5m 14.8ft	kg									*7,580	6,940	*7,160	5,140	*4,080	*4,080	10.00
	lb									*16,710	15,300	*15,790	11,330	*8,990	*8,990	(32.8)
3.0m 9.8ft	kg													*4,210	4,000	10.25
	lb													*9,280	8,820	(33.6)
1.5m 4.9ft	kg													*4,460	3,900	10.28
	lb													*9,830	8,600	(33.7)
Ground Line	kg													*4,880	3,960	10.08
	lb													*10,760	8,730	(33.1)
-1.5m -4.9ft	kg	*6,460	*6,460	*9,880	*9,880	*19,020	12,460	12,920	8,140	9,180	5,940	7,040	4,600	*5,570	4,190	9.64
	lb	*14,240	*14,240	*21,780	*21,780	*41,930	27,470	28,480	17,950	20,240	13,100	15,520	10,140	*12,280	9,240	(31.6)
-3.0m -9.8ft	kg	*10,380	*10,380	*14,460	*14,460	*18,480	12,470	12,870	8,100	9,150	5,910			*6,730	4,690	8.92
	lb	*22,880	*22,880	*31,880	*31,880	*40,740	27,490	28,370	17,860	20,170	13,030			*14,840	10,340	(29.3)
-4.5m -14.8ft	kg	*15,030	*15,030	*20,820	*20,820	*16,810	12,670	*12,610	8,210	9,280	6,030			8,700	5,690	7.86
	lb	*33,140	*33,140	*45,900	*45,900	*37,060	27,930	*27,800	18,100	20,460	13,290			19,180	12,540	(25.8)
-6.0m -19.7ft	kg													*8,930	8,100	6.26
	lb													*19,690	17,860	(20.5)

6.45m (21' 2") boom, 2.5m (8' 2") arm equipped with 600mm (24") triple grouser shoe.

Lift-point height (m/ft)	Lift-point radius								At max. reach			
	3.0m (9.8ft)		4.5m (14.8ft)		6.0m (19.7ft)		7.5m (24.6ft)		Capacity		Reach	
											m(ft)	
7.5m 24.6ft	kg									*8,850	7,950	6.93
	lb									*19,510	17,530	(22.7)
6.0m 19.7ft	kg									*9,350	*9,350	7.90
	lb									*20,610	*20,610	(25.9)
4.5m 14.8ft	kg											8.49
	lb											(27.9)
3.0m 9.8ft	kg											8.79
	lb											(28.8)
1.5m 4.9ft	kg											8.82
	lb											(28.9)
Ground Line	kg											8.58
	lb											(28.2)
-1.5m -4.9ft	kg											8.06
	lb											(26.4)
-3.0m -9.8ft	kg	*21,480	*21,480	*16,720	12,980	*12,820	8,450					7.19
	lb	*47,360	*47,360	*36,860	28,620	*28,260	18,630					(23.6)
-4.5m -14.8ft	kg											5.80
	lb											(19.0)

- 1 | Lifting capacity are based on ISO 10567.
- 2 | Lifting capacity of HX Series does not exceed 75% of tipping load with the machine on firm, level ground or 87% of full hydraulic capacity.
- 3 | The Lift-point is bucket pivot mounting pin on the arm (without bucket mass).
- 4 | (*) indicates load limited by hydraulic capacity.

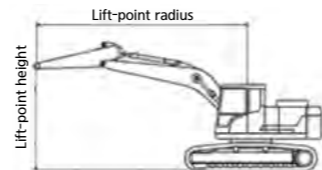

Rating over-front Rating over-side or 360 degree

HX330AL

6.45m (21' 2") boom, 2.2m (7' 3") arm equipped with 600mm (24") triple grouser shoe.

Lift-point height (m/ft)	Lift-point radius								At max. reach			
	3.0m (9.8ft)		4.5m (14.8ft)		6.0m (19.7ft)		7.5m (24.6ft)		Capacity		Reach	
											m(ft)	
7.5m 24.6ft	kg									*9,310	*9,310	6.71
	lb									*20,530	*20,530	(22.0)
6.0m 19.7ft	kg									*9,810	*9,810	7.71
	lb									*21,630	*21,630	(25.3)
4.5m 14.8ft	kg									*11,100	9,430	8.32
	lb									*24,470	20,790	(27.3)
3.0m 9.8ft	kg									*12,630	8,960	8.62
	lb									*27,840	19,750	(28.3)
1.5m 4.9ft	kg									13,410	8,610	8.65
	lb									29,560	18,980	(28.4)
Ground Line	kg									13,220	8,440	8.41
	lb									29,150	18,610	(27.6)
-1.5m -4.9ft	kg									*18,160	12,940	7.88
	lb									*40,040	28,530	(25.8)
-3.0m -9.8ft	kg	*20,450	*20,450	*16,230	13,150	*12,520	8,580					6.98
	lb	*45,080	*45,080	*35,780	28,990	*27,600	18,920					(22.9)
-4.5m -14.8ft	kg											5.54
	lb											(18.2)

6.15m (20' 2") boom, 2.2m (7' 3") arm equipped with 600mm (24") triple grouser shoe.

Lift-point height (m/ft)	Lift-point radius								At max. reach			
	3.0m (9.8ft)		4.5m (14.8ft)		6.0m (19.7ft)		7.5m (24.6ft)		Capacity		Reach	
											m(ft)	
7.5m 24.6ft	kg									*9,780	*9,780	6.31
	lb									*21,560	*21,560	(20.7)
6.0m 19.7ft	kg									*9,980	9,930	7.36
	lb									*22,000	21,890	(24.2)
4.5m 14.8ft	kg									*11,160	9,570	8.00
	lb									*24,600	21,100	(26.2)
3.0m 9.8ft	kg									*12,670	9,130	8.31
	lb									*27,930	20,130	(27.3)
1.5m 4.9ft	kg									13,600	8,790	8.34
	lb									29,980	19,380	(27.4)
Ground Line	kg									13,400	8,610	8.10
	lb									29,540	18,980	(26.6)
-1.5m -4.9ft	kg									*18,560	13,130	7.54
	lb									*40,920	28,950	(24.7)
-3.0m -9.8ft	kg	*21,300	*21,300	*16,420	13,350	*12,400	8,760					6.60
	lb	*46,960	*46,960	*36,200	29,430	*27,340	19,310					(21.6)
-4.5m -14.8ft	kg											
	lb											

- 1 | Lifting capacity are based on ISO 10567.
- 2 | Lifting capacity of HX Series does not exceed 75% of tipping load with the machine on firm, level ground or 87% of full hydraulic capacity.
- 3 | The Lift-point is bucket pivot mounting pin on the arm (without bucket mass).
- 4 | (*) indicates load limited by hydraulic capacity.

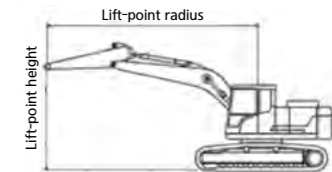

LIFTING CAPACITY

Rating over-front Rating over-side or 360 degree

Rating over-front Rating over-side or 360 degree

HX330AL NL

6.45m (21' 2") boom, 4.05m (13' 3") arm equipped with 600mm (24") triple grouser shoe.

Lift-point height (m/ft)	Lift-point radius										At max. reach				
	1.5m (4.9ft)		3.0m (9.8ft)		4.5m (14.8ft)		6.0m (19.7ft)		7.5m (24.6ft)		9.0m (29.5ft)		Capacity		Reach
															m(ft)
9.0m 29.5ft	kg									*4,740	*4,740		*4,530	*4,530	7.56
	lb									*10,450	*10,450		*9,990	*9,990	(24.8)
7.5m 24.6ft	kg												*4,190	*4,190	8.72
	lb												*9,240	*9,240	(28.6)
6.0m 19.7ft	kg									*6,840	6,210	*5,830	4,050	*4,070	9.51
	lb									*15,080	13,690	*12,850	9,940	*8,970	(31.2)
4.5m 14.8ft	kg									*7,590	5,970	*7,160	4,410	*4,080	10.00
	lb									*16,730	13,160	*15,790	9,720	*8,990	(32.8)
3.0m 9.8ft	kg									*13,400	12,150	*10,170	7,950	*8,570	10.25
	lb									*29,540	26,790	*22,420	17,530	*18,890	(33.6)
1.5m 4.9ft	kg									*16,640	11,110	*11,920	7,420	9,550	10.28
	lb									*36,680	24,490	*26,280	16,360	21,050	(33.7)
Ground Line	kg									*18,500	10,520	13,080	7,040	9,280	10.08
	lb									*40,790	23,190	28,840	15,520	20,460	(33.1)
-1.5m -4.9ft	kg	*6,480	*6,480	*9,910	*9,910	*19,020	10,300	12,840	6,830	9,120	5,010	6,990	3,880	*5,570	9.64
	lb	*14,290	*14,290	*21,850	*21,850	*41,930	22,710	28,310	15,060	20,110	11,050	15,410	8,550	*12,280	(31.6)
-3.0m -9.8ft	kg	*10,400	*10,400	*14,490	*14,490	*18,480	10,310	12,790	6,790	9,090	4,980			*6,740	8.92
	lb	*22,930	*22,930	*31,940	*31,940	*40,740	22,730	28,200	14,970	20,040	10,980			*14,860	(29.3)
-4.5m -14.8ft	kg	*15,060	*15,060	*20,860	20,540	*16,800	10,500	*12,600	6,900	9,230	5,100			8,660	7.85
	lb	*33,200	*33,200	*45,990	45,280	*37,040	23,150	*27,780	15,210	20,350	11,240			19,090	(25.8)
-6.0m -19.7ft	kg			*18,490	*18,490	*13,330	10,920	*9,580	7,240					*8,930	6.24
	lb			*40,760	*40,760	*29,390	24,070	*21,120	15,960					*19,690	(20.5)

6.45m (21' 2") boom, 3.2m (10' 6") arm equipped with 600mm (24") triple grouser shoe.

Lift-point height (m/ft)	Lift-point radius										At max. reach			
	3.0m (9.8ft)		4.5m (14.8ft)		6.0m (19.7ft)		7.5m (24.6ft)		9.0m (29.5ft)		Capacity		Reach	
													m(ft)	
7.5m 24.6ft	kg							*6,850	6,150			*5,610	*5,610	7.75
	lb							*15,100	13,560			*12,370	*12,370	(25.4)
6.0m 19.7ft	kg							*7,900	6,090			*5,430	4,770	8.62
	lb							*17,420	13,430			*11,970	10,520	(28.3)
4.5m 14.8ft	kg			*12,040	*12,040	*9,710	8,290	*8,550	5,890	*6,680	4,360	*5,450	4,220	9.17
	lb			*26,540	*26,540	*21,410	18,280	*18,850	12,990	*14,730	9,610	*12,020	9,300	(30.1)
3.0m 9.8ft	kg			*15,620	11,680	*11,400	7,790	*9,440	5,630	7,380	4,250	*5,660	3,930	9.44
	lb			*34,440	25,750	*25,130	17,170	*20,810	12,410	16,270	9,370	*12,480	8,660	(31.0)
1.5m 4.9ft	kg			*17,420	10,880	*12,920	7,350	9,530	5,390	7,250	4,130	*6,060	3,820	9.47
	lb			*38,400	23,990	*28,480	16,200	21,010	11,880	15,980	9,110	*13,360	8,420	(31.1)
Ground Line	kg			*17,270	10,550	13,090	7,070	9,330	5,220	7,150	4,050	*6,730	3,900	9.25
	lb			*38,070	23,260	28,860	15,590	20,570	11,510	15,760	8,930	*14,840	8,600	(30.3)
-1.5m -4.9ft	kg	*10,830	*10,830	*18,990	10,490	12,960	6,960	9,250	5,140			7,410	4,180	8.77
	lb	*23,880	*23,880	*41,870	23,130	28,570	15,340	20,390	11,330			16,340	9,220	(28.8)
-3.0m -9.8ft	kg	*17,510	*17,510	*17,780	10,610	13,010	7,000	9,300	5,190			8,550	4,810	7.97
	lb	*38,600	*38,600	*39,200	23,390	28,680	15,430	20,500	11,440			18,850	10,600	(26.2)
-4.5m -14.8ft	kg	*20,690	*20,690	*15,260	10,900	*11,460	7,210					*9,660	6,190	6.75
	lb	*45,610	*45,610	*33,640	24,030	*25,260	15,900					*21,300	13,650	(22.1)

- 1 | Lifting capacity are based on ISO 10567.
- 2 | Lifting capacity of HX Series does not exceed 75% of tipping load with the machine on firm, level ground or 87% of full hydraulic capacity.
- 3 | The Lift-point is bucket pivot mounting pin on the arm (without bucket mass).
- 4 | (*) indicates load limited by hydraulic capacity.

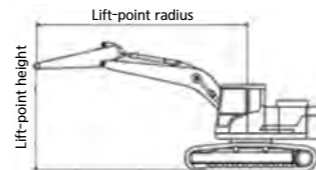

HX330A NL

6.45m (21' 2") boom, 2.5m (8' 2") arm equipped with 600mm (24") triple grouser shoe.

Lift-point height (m/ft)	Lift-point radius										At max. reach			
	3.0m (9.8ft)		4.5m (14.8ft)		6.0m (19.7ft)		7.5m (24.6ft)		Capacity		Reach			
											m(ft)			
7.5m 24.6ft	kg											*8,850	6,860	6.93
	lb											*19,510	15,120	(22.7)
6.0m 19.7ft	kg											*9,350	8,530	7.90
	lb											*20,610	18,810	(25.9)
4.5m 14.8ft	kg											*13,800	12,350	8.49
	lb											*30,420	27,230	(27.9)
3.0m 9.8ft	kg											*12,250	7,640	8.79
	lb											*27,010	16,840	(28.8)
1.5m 4.9ft	kg											13,310	7,260	8.82
	lb											29,340	16,010	(28.9)
Ground Line	kg											*15,250	10,560	8.58
	lb											*33,620	23,280	(28.2)
-1.5m -4.9ft	kg											*18,440	10,610	8.06
	lb											*40,650	23,390	(26.4)
-3.0m -9.8ft	kg	*21,550	21,230	*16,710	10,800	*12,810	7,140							7.18
	lb	*47,510	46,800	*36,840	23,810	*28,240	15,740							(23.6)
-4.5m -14.8ft	kg													5.79
	lb													(19.0)

6.45m (21' 2") boom, 2.2m (7' 3") arm equipped with 600mm (24") triple grouser shoe.

Lift-point height (m/ft)	Lift-point radius										At max. reach			
	3.0m (9.8ft)		4.5m (14.8ft)		6.0m (19.7ft)		7.5m (24.6ft)		Capacity		Reach			
											m(ft)			
7.5m 24.6ft	kg											*9,310	8,690	6.72
	lb											*20,530	19,160	(22.0)
6.0m 19.7ft	kg											*9,820	8,490	7.71
	lb											*21,650	18,720	(25.3)
4.5m 14.8ft	kg											*11,110	8,080	8.32
	lb											*24,490	17,810	(27.3)
3.0m 9.8ft	kg											*12,640	7,630	8.62
	lb											*27,870	16,820	(28.3)
1.5m 4.9ft	kg											13,330	7,290	8.65
	lb											29,390	16,070	(28.4)
Ground Line	kg											13,140	7,130	8.41
	lb											28,970	15,720	(27.6)
-1.5m -4.9ft	kg											*18,160	10,770	7.87
	lb											*40,040	23,740	(25.8)
-3.0m -9.8ft	kg	*20,430	*20,430	*16,220	10,970	*12,510	7,270							6.97
	lb	*45,040	*45,040	*35,760	24,180	*27,580	16,030							(22.9)
-4.5m -14.8ft	kg													5.53
	lb													(18.1)

- 1 | Lifting capacity are based on ISO 10567.
- 2 | Lifting capacity of HX Series does not exceed 75% of tipping load with the machine on firm, level ground or 87% of full hydraulic capacity.
- 3

LIFTING CAPACITY

Rating over-front Rating over-side or 360 degree

HX330AL HIGH WALKER

6.45m (21' 2") boom, 2.2m (7' 3") arm equipped with 600mm (24") double grouser shoe.

Lift-point height (m/ft)		Lift-point radius								At max. reach		
		3.0m (9.8ft)		4.5m (14.8ft)		6.0m (19.7ft)		7.5m (24.6ft)		Capacity		Reach (m/ft)
9.0m 29.5ft	kg lb									*9,980 *22,000	*9,980 *22,000	5.47 (18.0)
7.5m 24.6ft	kg lb			*9,310 *20,530	*9,310 *20,530					*9,390 *20,700	9,150 20,170	6.94 (22.8)
6.0m 19.7ft	kg lb			*10,010 *22,070	*10,010 *22,070	*9,240 *20,370	8,040 17,730			*9,250 *20,390	7,440 16,400	7.85 (25.8)
4.5m 14.8ft	kg lb			*11,400 *25,130	10,930 24,100	*9,730 *21,450	7,860 17,330			9,160 20,190	6,610 14,570	8.40 (27.6)
3.0m 9.8ft	kg lb			*12,900 *28,440	10,470 23,080	*10,440 *23,020	7,640 16,840			8,650 19,070	6,220 13,710	8.65 (28.4)
1.5m 4.9ft	kg lb			*13,940 *30,730	10,150 22,380	10,510 23,170	7,460 16,450			8,590 18,940	6,160 13,580	8.63 (28.3)
Ground Line	kg lb			*14,250 *31,420	10,010 22,070	10,410 22,950	7,370 16,250			8,990 19,820	6,420 14,150	8.33 (27.3)
-1.5m -4.9ft	kg lb			*17,880 *39,420	15,490 34,150	*13,740 *30,290	10,030 22,110	10,450 23,040	7,410 16,340	10,020 22,090	7,130 15,720	7.74 (25.4)
-3.0m -9.8ft	kg lb	*19,800 *43,650	*19,800 *43,650	*15,700 *34,610	*15,700 *34,610	*12,050 *26,570	10,220 22,530			*10,110 *22,290	8,740 19,270	6.75 (22.2)

- 1 | Lifting capacity are based on ISO 10567.
- 2 | Lifting capacity of HX Series does not exceed 75% of tipping load with the machine on firm, level ground or 87% of full hydraulic capacity.
- 3 | The Lift-point is bucket pivot mounting pin on the arm(without bucket mass).
- 4 | (*) indicates load limited by hydraulic capacity.

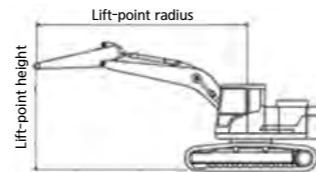

BUCKET SELECTION GUIDE & DIGGING FORCE

BUCKETS



SAE heaped
m³ (yd³)

1.44 (1.88)
1.74 (2.28)
2.10 (2.75)



◆1.44 (1.88)



◆1.44 (1.88)
◆1.60 (2.09)
◆1.73 (2.26)
◆1.83 (2.39)

Capacity m ³ (yd ³)		Width mm (in)		Weight kg (lb)	Recommendation mm (ft-in)						
					6,150 (20' 2") Boom			6,450 (21' 2") Boom			
SAE heaped	CECE heaped	Without side cutters	With side cutters		2,200 (7' 3") Arm	2,500 (8' 2") Arm	3,200 (10' 6") Arm	2,200 (7' 3") Arm	2,500 (8' 2") Arm	3,200 (10' 6") Arm	4,050 (13' 3") Arm
1.44 (1.88)	1.25 (1.63)	1,380 (54")	1,500 (59")	1,110 (2,450)	●	●	●	●	●	●	●
1.74 (2.28)	1.50 (1.96)	1,620 (64")	1,740 (69")	1,230 (2,710)	●	●	●	●	●	●	■
2.10 (2.75)	1.83 (2.39)	1,910 (75")	2,030 (80")	1,370 (3,020)	●	●	■	●	■	■	▲
◆1.44 (1.88)	1.25 (1.63)	1,470 (58")	-	1,380 (3,040)	●	●	●	●	●	●	●
◆1.44 (1.88)	1.25 (1.63)	1,470 (58")	-	1,470 (3,240)	●	●	●	●	●	●	-
◆1.60 (2.09)	1.39 (1.82)	1,585 (62")	-	1,650 (3,640)	●	●	●	●	●	●	-
◆1.73 (2.26)	1.50 (1.96)	1,710 (67")	-	1,650 (3,640)	●	●	●	●	●	■	-
◆1.83 (2.39)	1.59 (2.08)	1,765 (69")	-	1,845 (4,070)	●	●	■	●	●	■	-

- ◆ Heavy duty bucket
- ◆ Rock-Heavy duty bucket
- Slope finishing bucket
- : Applicable for materials with density of 2,100 kgf/m³ (3,500 lbf/yd³) or less
- : Applicable for materials with density of 1,800 kgf/m³ (3,000 lbf/yd³) or less
- : Applicable for materials with density of 1,500 kgf/m³ (2,500 lbf/yd³) or less
- ▲ : Applicable for materials with density of 1,200 kgf/m³ (2,000 lbf/yd³) or less

ATTACHMENT

Booms and arms are welded with a low-stress, full-box section design.
6.45 m, 6.15 m Booms and 2.2 m, 2.5 m, 3.2 m, 4.05 m Arms are available.

DIGGING FORCE

Boom	Length	mm (ft-in)	6,150 (20' 2")		6,450 (21' 2")			Remark
	Weight	kg (lb)	2,950 (6,500)		3,030 (6,680)			
Arm	Length	mm (ft-in)	2,200 (7' 3")	2,200 (7' 3")	2,500 (8' 2")	3,200 (10' 6")	4,050 (13' 3")	Power Boost
	Weight	kg (lb)	1,560 (3,440)	1,560 (3,440)	1,650 (3,640)	1,770 (3,900)	1,870 (4,120)	
Bucket digging force	SAE	kN	186.3 [203.3]	186.3 [203.3]	187.3 [204.4]	188.3 [205.5]	189.3 [206.4]	[]: Power Boost
		kgf	19,000 [20,730]	19,000 [20,730]	19,100 [20,840]	19,200 [20,950]	19,300 [21,050]	
		lbf	41,890 [45,700]	41,890 [45,700]	42,110 [45,940]	42,330 [46,190]	42,550 [46,410]	
	ISO	kN	214.8 [234.3]	214.8 [234.3]	215.7 [235.4]	216.7 [236.4]	217.7 [237.5]	
		kgf	21,900 [23,890]	21,900 [23,890]	22,000 [24,000]	22,100 [24,110]	22,200 [24,220]	
		lbf	48,280 [52,670]	48,280 [52,670]	48,500 [52,910]	48,720 [53,150]	48,940 [53,400]	
Arm crowd force	SAE	kN	195.2 [212.9]	195.2 [212.9]	175.5 [191.5]	140.2 [153.0]	118.7 [129.4]	
		kgf	19,900 [21,710]	19,900 [21,710]	17,900 [19,530]	14,300 [15,600]	12,100 [13,200]	
		lbf	43,870 [47,860]	43,870 [47,860]	39,460 [43,060]	31,530 [34,390]	26,680 [29,100]	
	ISO	kN	205.0 [223.6]	205.0 [223.6]	184.4 [201.1]	145.1 [158.4]	123.6 [134.8]	
		kgf	20,900 [22,800]	20,900 [22,800]	18,800 [20,510]	14,800 [16,150]	12,600 [13,750]	
		lbf	46,080 [50,270]	46,080 [50,270]	41,450 [45,220]	32,630 [35,600]	27,780 [30,310]	

Note : Boom weight includes arm cylinder, piping, and pin Arm weight includes bucket cylinder, linkage, and pin

STANDARD / OPTION

ENGINE	
Cummins L9 Engine	●
HYDRAULIC SYSTEM	
INTELLIGENT POWER CONTROL (IPC)	
3-Power Mode, 2-Work Mode, User Mode	●
Variable Power Control	●
Pump Flow Control (Upgraded IPC)	●
Attachment Mode Flow Control	
Engine Auto Idle	●
Engine Auto Shutdown Control	●
Hyundai Bio Hydraulic Oil (HBHO)	
CAB & INTERIOR	
ISO STANDARD CABIN	
Cabin Lights (LED)	
LED Room Lamp	●
Cabin Front Window Rain Guard	
Cabin Roof-Steel Cover	
Low Wiper	
Rise-Up Type Windshield Wiper	●
Radio / USB Player	●
Handsfree Mobile Phone System with USB	●
12 Volt Power Outlet (24V DC to 12V DC Converter)	●
Electric Horn	●
All-Weather Steel Cab with 360° Visibility	●
Safety glass - Tempered glass	●
Safety glass - Tempered glass with front laminated glass	●
Sliding Fold-In Front Window	●
Sliding Side Window(LH)	●
Hot & Cool Box	●
Storage Compartment and Ashtray	●
Transparent Cabin Roof-Cover	●
Sun Visor	●
Door and Cab Locks, One Key	●
Smart Key & Start	
Mechanical Suspension Seat With Heater	●
Pilot-Operated Slidable Joystick	●
Console Box Height Adjust System	●
AUTOMATIC CLIMATE CONTROL	
Air Conditioner & Heater	●
Defroster	●
AUTOMATIC STARTING AID(AIR GRID HEATER) FOR WEATHER	
Starting Aid (Air grid heater) for Cold Weather	●
CENTRALIZED MONITORING	
8" LCD Display	●
Engine Speed or Trip Meter/Accel.	●
Engine Coolant Temperature Gauge	●
Max Power	●
Low Speed/High Speed	●
Auto Idle	●
Overload warning with alarm	
Check Engine	●
Air Cleaner Clogging	●
Indicators	●
ECO Gauges	●
Fuel Level Gauge	●
Hyd. Oil Temperature Gauge	●
Fuel Warmer	●
Warnings	●
Communication Error	●
Low Battery	●
Clock	●
SEAT	
Adjustable Air Suspension Seat with Heater	
CABIN FOPS/FOG (ISO 10262) LEVEL 2	
FOPS (Falling Object Protective Structure) · ISO 10262 Level 2	

CAB & INTERIOR	
CABIN ROPS (ISO 12117-2)	
ROPS (Roll Over Protective Structure)	●
SAFETY	
Battery Master Switch	●
Rearview Camera	
AAVM (Advanced Around View Monitoring)	
Six Front Working Lights (4 Boom Mounted, 2 Front Frame Mounted)	●
Travel Alarm	●
Rear Work Lamp	
Beacon Lamp	
Automatic Swing Brake	●
Boom Holding System	●
Arm Holding System	●
Safety Lock Valve for Boom Cylinder with Overload Warning Device	
Safety Lock Valve for Arm Cylinder	
Swing Lock System	
Three Outside Rearview Mirror	●
OTHERS	
Removable Clean-Out Dust Net for Cooler	●
Removable Reservoir Tank	●
Fuel Pre-Filter(1,000hr)	●
Fuel Warmer	●
Self-Diagnostics System	●
Hi MATE (Remote Management System)	
Batteries (2 x 12V x 160 AH)	●
Fuel Filler Pump (50 L/min)	
Single-Acting Piping Kit (Breaker, etc.)	
Double-Acting Piping Kit (Clamshell, etc.)	
Rotating Piping Kit	
Quick Coupler Piping	
Quick Coupler	
Boom Floating Control	
One Pedal Straight Travel System	
Accumulator for Lowering Work Equipment	●
Pattern Change Valve (2 Patterns)	
Tool Kit	
BOOMS	
6.15m, 20' 2"	
6.45m, 21' 2"	●
ARMS	
2.2m, 7' 3"	
2.5m, 8' 2"	
3.2m, 10' 6"	●
4.05m, 13' 3"	
UNDERCARRIAGE	
Lower Frame Under Cover (Additional)	
Lower Frame Under Cover (Normal)	●
TRACK SHOES	
Triple Grousers Shoe (600mm, 24")	●
Triple Grousers Shoe (700mm, 28")	
Triple Grousers Shoe (800mm, 32")	
Triple Grousers Shoe (900mm, 36")	
Double Grousers Shoe (700mm, 28")	
Track Rail Guard	●
Full Track Rail Guard	

* Standard and optional equipment may vary. Contact your Hyundai dealer for more information. The machine may vary according to International standards.
 * The photos may include attachments and optional equipment that are not available in your area.
 * Materials and specifications are subject to change without advance notice.
 * All imperial measurements rounded off to the nearest pound or inch.

MEMO

MEMO

MEMO