

OPTION LIST

ENGINE	SAFETY
Big size radiator & tropical oil	Beacon light, rotating
Fuel heater	OTHER
Oil bath air cleaner	Rear view camera
Cold start package & arctic oil	High lift boom
POWER TRAIN	Short boom
Electronic transmission	Rock bucket
Tires	Light bucket
Solid tire	Side dump
23.5 R25 REM2 tire	ROPS/ FOPS Cabin (HL660L+/HL665L+)
HYDRAULIC SYSTEM	Rear window wiper
Hydraulic control, 3 spool	Rear work light

MATERIAL HANDLER PACKAGE (ONLY FOR HL665L+)

ATTACHMENT			
Quick coupler	Weight	kg	479
	Overall Dimensions (L×W×H)	mm	1416×492×800
Pallet fork	Load Capacity	kg	5000
	Overall Dimensions (L×W×H)	mm	2146×1892×1097
	Length of Fork	mm	1800
	Retraction Angle of Fork	/	15°
Log fork	Overall Dimensions (L×W×H)	mm	1750×2300×1600
	Load Capacity	kg	5000
	Maximum Opening	mm	1900
	Overall Weight	kg	1460
Grass grapple	Minimum Circle Diameter	mm	∅1160
	Load Capacity	kg	5000
	Maximum Opening	mm	2568
	Overall Dimensions (L×W×H)	mm	1860×2456×1550
Jib crane	Overall Length	mm	1958
	Overall Width	mm	1540
	Overall Height	mm	1028
	Max Load Weight	t	5
	Overall Weight (included attachment)	kg	459



Head Office(Sales Office)
14F, GLOBAL R&D CENTER, 477 BUNDANG SUSEO-RO, BUNDANG-GU, SEONGNAM-SI, GYEONGGI-DO, 13553, KOREA

PLEASE CONTACT

HL630L+/HL635L+ HL660+/HL665+ HL660L+/HL665L+

With Tier 2 / Stage II Engine Installed

* Photo may include optional equipment.



Model	Gross Power	Bucket Capacity	Operating Weight
HL630L+/HL635L+	92 kW at 2,000 rpm	1.7m ³	10,300/10,400 kg
HL660+/HL665+	162 kW at 2,000 rpm	3m ³	16,800/17,300 kg
HL660L+/HL665L+			17,330/18,000 kg

HYUNDAI

HYUNDAI + SERIES WHEEL LOADER DESIGN THE FUTURE, BUILT TO LAST

Evolution in design: same excellence, elevated aesthetics.

The upgraded HL630L+/HL635L+, HL660+/HL665+, HL660L+/HL665L+ loaders present a more distinctive livery and ergonomically enhanced cab design preserving their powerful performance while commanding attention with bold, purposeful styling.



BOOM/ATTACHMENT OPTION			BOOM/ATTACHMENT OPTION		
Model	Standard Bucket Capacity	Optional	Model	Standard Bucket Capacity	Optional
HL630L+ HL635L+	1.7 m ³	High Dump (Long Boom)	HL660+ HL665+ HL660L+ HL665L+	3.0 m ³	High Dump (Long Boom)
		Coal Bucket (2.0 m ³ , 2.0 m ³ BOE)			Side Dump
		Light Material Hopper (2.4 m ³)			Rock Bucket (2.7 m ³ BOT)
					Sand Stone Bucket (3.3 m ³ BOT)
					Coal Bucket (3.5 m ³ BOT/BOE, 4.0 m ³ BOT)
					Enlarged Bucket (4.5 m ³ BOT/BOE)

OUTSTANDING PRODUCTIVITY AND FUEL EFFICIENCY



Max. Speed
36.0 km/h

Operating Weight
10,300/17,300 kg

Bucket Capacity
1.7/3.0 m³

Power (Gross)
92/2,000, 162/2,000 kW/rpm

Powerful & Fuel-Efficient Turbocharged Engine

- Equipped with a Weichai turbocharged engine, delivering max power of 92/162 kW and peak torque of 500/980 N · m(1200-1400/1400-1500 rpm) for superior performance.
- Compliant with EPA Tier II & EU Stage II emission standards, ensuring high fuel efficiency and lower operating costs.



Upgraded Hydraulic Pilot Control System **NEW**

- Added an accumulator to the original hydraulic pilot control system, allowing the boom to be lowered even when the engine is off, improving product safety.
- Installed a pilot filter in the pilot control lines to reduce impurities and minimize failure rates.



Straight Pipe Design of Hydraulic System **NEW**

- Replaced the hose at the center joint with a straight pipe design. This eliminates stress-induced oil leaks at bending points and removes hose kinking issues, while also improving overall aesthetics.
- Reduced the complex tubing between the control valve and bucket cylinder to a single hose connection, streamlining the system.



Enlarged Cowl Vent Holes **NEW**

- The new side panels are 24% larger than previous models, significantly improving maintenance convenience.
- The vent holes have also been enlarged to enhance radiator cooling efficiency.



ENGINEERING RELIABILITY: OPTIMIZED HEAVY-DUTY PERFORMANCE



Optimized Powertrain for Superior Performance

- Best-in-Class Engine & Transmission Pairing. Weichai engine + durable mechanical transmission & torque converter for maximum power and efficiency.
- Torque converter ensures smooth power delivery in all working conditions.
- Flexible gear selection for precise control based on job demands.



Heavy-Duty Axle System for High Grade Stability

- Robust Front & Rear Axles - Built to withstand harsh terrains and heavy loads.
- Enhanced Running Stability - Ensures steady performance even in poor ground conditions.



Ultra-Durable Structural Design

- Finite Element Analysis (FEA) ensures superior strength and longevity.
- Reinforced framework for extended product life.



Enhanced Cooling Efficiency with Optimized Radiator Design NEW

- Upgraded radiator core design significantly improves heat dissipation, ensuring stable performance even under heavy loads and high temperatures.
- Features the new CI brand logo, combining superior functionality with a sleek, professional appearance.



ENHANCED OPERATOR COMFORT: UPGRADED CABIN & INTELLIGENT DEVICE

Enhanced Cabin Design **NEW**

- More Spacious Interior
Redesigned layout provides greater room and comfort
- Improved Sealing
Enhanced door and window seals for better insulation
- Reduced Noise & Dust
Tighter construction minimizes external disturbances



Suspension Seat with Seat Belt

- New Suspension Seat: Provides improved vibration damping and all-day comfort
- Standard 2" Retractable Seat Belt: Now included as default safety equipment (previously optional)



Multi-Directional Air Vents **NEW**

- Customizable vent directions allow personalized climate control
- Improved air circulation throughout the cab, Reduced fatigue from uneven temperature distribution



Standard Rear View Mirror

- Standard Back Mirror for Enhanced Safety and Visibility
- Improved jobsite awareness and safety, reduced blind spots during operation



Integrated Control Panel **NEW**

- Streamlined Interface: More integrated control layout
- Dual USB Ports: Supports simultaneous device charging/connectivity
- Added Wrist Rest: Comfortable arm positioning during operation



Rear View Camera **Option**

- Eliminates blind spots behind the machine
- Provides clear view when reversing
- Works in low-light/dusty conditions



LED Work Lights

- 4 LED work lights: Energy efficient, high brightness LED work lights are equipped for superior illumination

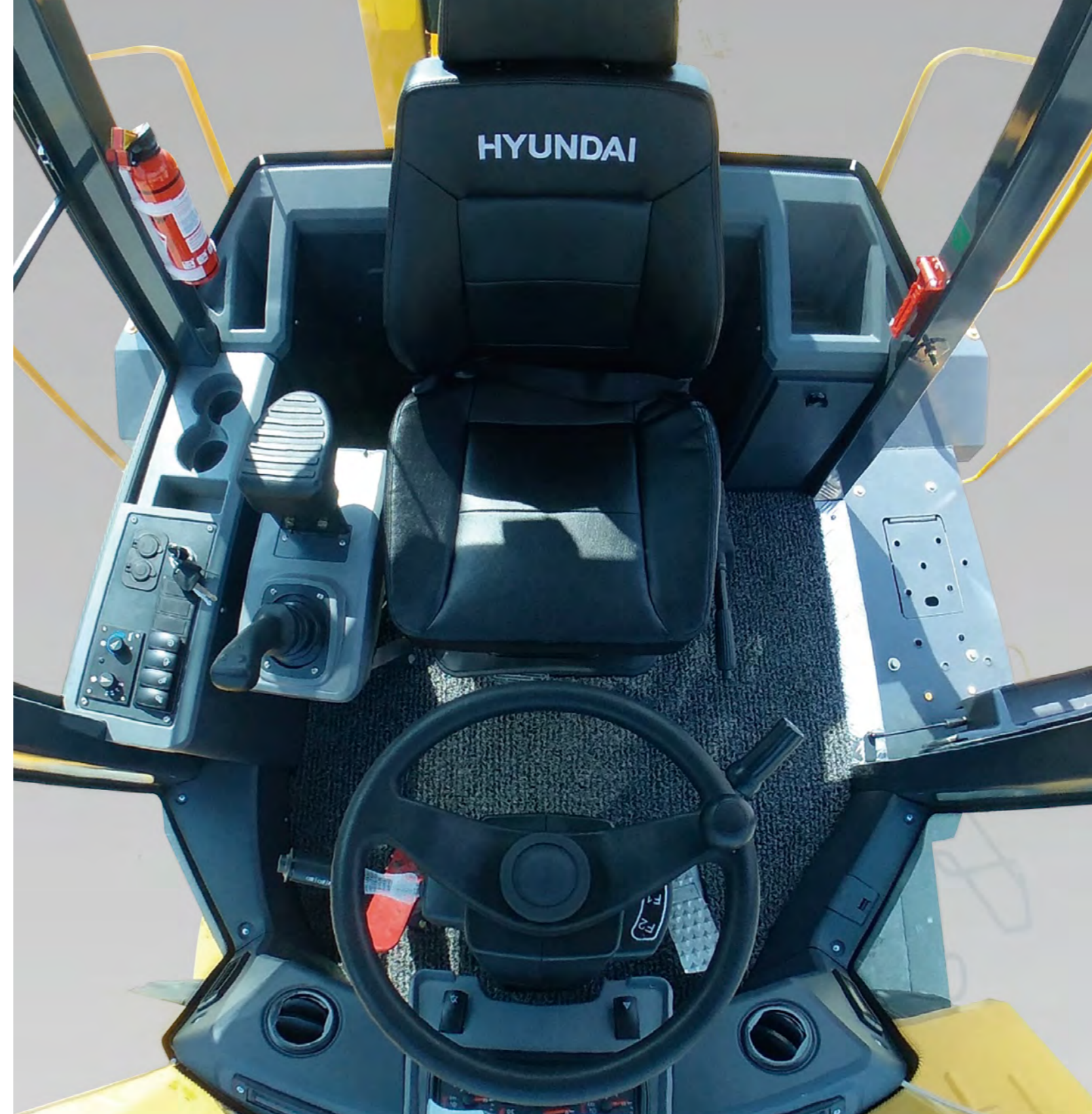

Upgraded Instrument Cluster **NEW**

- Enhanced dash with smarter machine data visualization.
- Upgraded gauges + digital readouts for critical parameters (Engine RPM, Transmission oil temperature, Hydraulic oil pressure/temperature, Coolant temperature)
- Features Hyundai's new logo startup animation - enhancing both dashboard aesthetics and brand identity.



EFFORTLESS MAINTENANCE, UNINTERRUPTED WORK



Non-Slip Platform

Non-slip platform and steps ensure operator's safety.



Easy Access to Engine Compartment Oil Level Gauge

Engine hood with two side wing flap opened door provide access for maintenance to easily replace engine components and perform daily maintenance.



The hydraulic oil check sight gauge is installed on the side of the hydraulic tank for the convenience of maintenance check from ground level.



Battery Relay **NEW**

Centralized Waterproof Fuse Box for Batteries - Simplifying Maintenance & Inspection.



Quick Changeable Brake System

The brake discs can be replaced quickly and easily without removing the tires, which saves maintenance time.



Easy access filter **NEW**

New transmission fine-filter structure mounted at the articulation point for enhanced maintenance accessibility.



Enhanced Bucket Tooth Design **NEW**

5mm increased thickness for 30% longer service life. Internal bolt/nut configuration eliminating external protrusions.

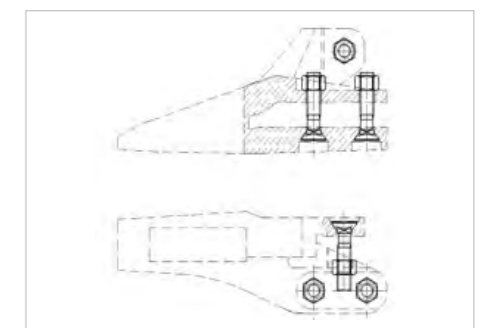

+ SERIES WHEEL LOADER SPECIFICATIONS

ENGINE

Description	HL630L+/HL635L+	HL660+/HL665+	HL660L+/HL665L+
Maker	WEICHAI	WEICHAI	WEICHAI
Model	WP6G125E23	WD10G220E23	
Emission regulation	Tier II	Tier II	Tier II
Power (Gross)	92 kW (125 hp) / 2,300 rpm	162 kW (217 hp) /2,000 rpm	162 kW (217 hp) /2,000 rpm
Power (Net)	87 kW (118hp) / 2,300 rpm	146kW (196 hp) /2,000 rpm	146kW (196 hp) /2,000 rpm
Max. torque	500 N · m / 1,700 rpm	900 N · m /1,400 rpm	900 N · m /1,400 rpm
Displacement	6.750 ℓ	9.726 ℓ	9.726 ℓ
No. of cylinders	6 EA	6 EA	6 EA

TRANSMISSION

Description	HL630L+/HL635L+	HL660+/HL665+	HL660L+/HL665L+
Transmission type	Fixed axis power shift	Planetary hydraulic shift	
Transmission configuration	4F-2R	2F-1R	2F-1R
Torque converter	3 Element single stage	4 Elements single phase, twin-turbine	
Tire	17.5-25 L3	23.5-25 L3	
Travel speed (F1)	7 km/h	12 km/h	11.5 km/h
Travel speed (F2)	13 km/h	36 km/h	36 km/h
Travel speed (F3)	24 km/h	/	
Travel speed (F4)	36 km/h	/	
Travel speed (R1)	9 km/h	17 km/h	16 km/h
Travel speed (R2)	29 km/h	/	

OVERVIEW

Description	HL630L+/HL635L+	HL660+/HL665+	HL660L+/HL665L+
Operating weight	10,300 kg	16,700 kg	17,700 kg
Bucket capacity(Heaped)	1.7 m ³	2.7 m ³	3 m ³
Bucket capacity (Struck)	/	/	/
Breakout force	10,000 kgf	15,400 kgf	16,200 kgf
Tipping load(Full turn)	6,000 kgf	9052 kgf	10,540 kgf
Tipping load(Straight)	7,377 kgf	10283 kgf	11,139 kgf

HYDRAULIC SYSTEM

Description	HL630L+/HL635L+	HL660+/HL665+	HL660L+/HL665L+
Pump type	Fixed gear pump		
Flow rate	200 lpm	200 lpm	
System pressure	16 MPa	18 MPa	18 MPa
Cycle time (Lift with load)	5.1 sec		
Cycle time (Dump with load)	1.4 sec	1.3 sec	1.6 sec
Cycle time (Lower)	2.6 sec	4.2 sec	3.3 sec
Cycle time (Total)	9.1 sec	10.6 sec	10 sec
No. of cylinders	6 EA	6 EA	6 EA

STEERING

Description	HL630L+/HL635L+	HL660+/HL665+	HL660L+/HL665L+
Pump type	Fixed gear pump		
Flow rate	/	160 lpm	
System pressure	12 MPa	16 MPa	16 MPa
Articulation angle	35 °		

SERVICE REFILL CAPACITIES

Description	HL630L+/HL635L+	HL660+/HL665+	HL660L+/HL665L+
Fuel tank (Refill)	180 ℓ	290 ℓ	
Hydraulic tank	140 ℓ	210 ℓ	
Hydraulic system (Including tank)	180 ℓ	290 ℓ	
Coolant	38 ℓ	50 ℓ	
Crank case	13 ℓ	22 ℓ	
Transmission	36 ℓ	50 ℓ	
Front axle	18 ℓ	30 ℓ	
Rear axle	18 ℓ	30 ℓ	

AXLES

Description	HL630L+/HL635L+	HL660+/HL665+	HL660L+/HL665L+
Differential front type	Conventional only		
Differential rear type	Conventional only		
Rear axle oscillation	±10 °		

DIMENSIONS & WORKING RANGE

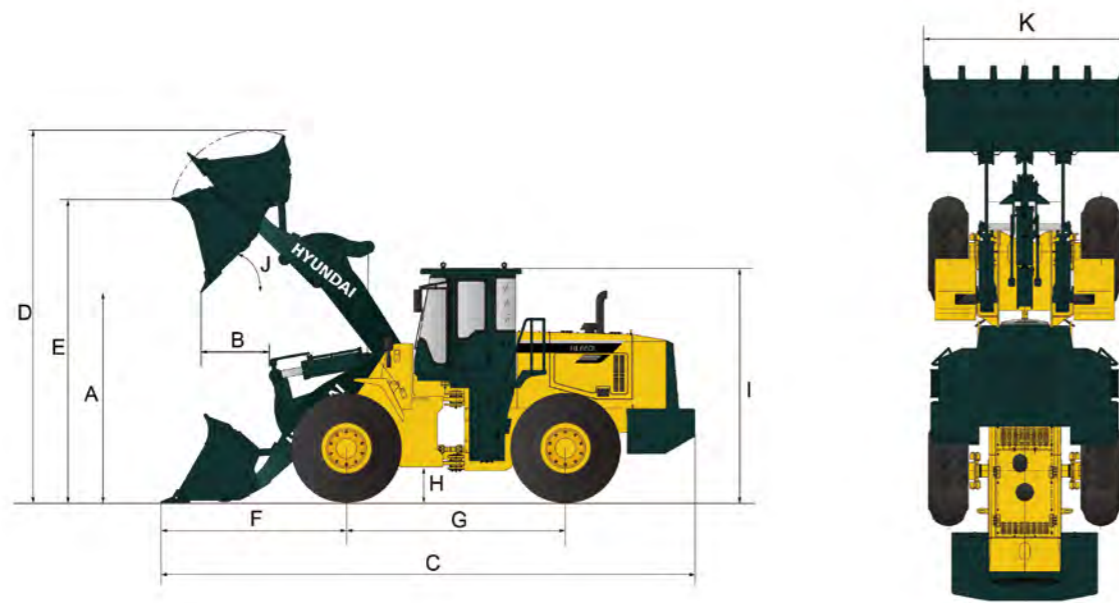

HL630L+ / 635L+ DIMENSIONS

All dimensions are approximate.

Item	Description	Standard	Longboom OPT
A	Dump clearance at 45° (Full lift)	2,850 mm	3,200 mm
B	Reach at 45° (Full lift)	1,000 mm	1,080 mm
C	Overall length (Ground)	7,040 mm	7,440 mm
	Overall length (Carry)	6,890 mm	7,290 mm
D	Overall height (Full raised)	4,679 mm	5,113 mm
E	Bucket pivot max. height	3,683mm	4,056 mm
F	Front overhang	2,310 mm	2,790mm
G	Wheel base	2,870 mm	2,870 mm
H	Ground clearance	345 mm	345 mm
I	Overall height (Cabin)	3,200 mm	3,200 mm
J	Rollback angle (Ground)	45 °	45 °
	Rollback angle (Carry)	48 °	48 °
K	Dump angle	46 °	46 °
L	Overall width (with Bucket)	2,460 mm	2,460 mm
	Overall width (without Bucket)	2,310 mm	2,310 mm
	Clearance circle (Bucket)	12,160 mm	12,830 mm
	Turning radius (Center of outside tire)	5,545 mm	5,545 mm

HL660+ / 665+ DIMENSIONS

All dimensions are approximate.

Item	Description	Standard	Longboom OPT
A	Dump clearance at 45° (Full lift)	3,150 mm	3,560 mm
B	Reach at 45° (Full lift)	1,315 mm	1,475 mm
C	Overall length (Ground)	7,830 mm	8,154 mm
	OVERALL LENGTH (CARRY)	7,670 mm	7,988 mm
D	Overall height (Full raised)	5,340 mm	5,693 mm
E	Bucket pivot max. height	4,150 mm	4,550 mm
F	Front overhang	2,832 mm	3,156 mm
G	Wheel base	3,000 mm	3,000 mm
H	Ground clearance	480 mm	480 mm
I	Overall height (Cabin)	3,540 mm	3,540 mm
J	Dump angle	45 °	45 °
K	Overall width (with Bucket)	2,990 mm	2,990 mm
	Overall width (without Bucket)	2,840 mm	2,840 mm
	Rollback angle (Ground)	42 °	41 °
	Rollback angle (Carry)	49 °	48 °
	Clearance circle (Bucket)	13,896 mm	14,152 mm
	Turning radius (Center of outside tire)	6,063 mm	6,063 mm

HL660L+ / 665L+ DIMENSIONS

All dimensions are approximate.

Item	Description	Standard	Longboom OPT
A	Dump clearance at 45° (Full lift)	3,100 mm	3,420 mm
B	Reach at 45° (Full lift)	1,220 mm	1,440 mm
C	Overall length (Ground)	7,980 mm	8,200 mm
	OVERALL LENGTH (CARRY)	7,760 mm	7,960 mm
D	Overall height (Full raised)	5,175 mm	5,690 mm
E	Bucket pivot max. height	4,180 mm	4,410 mm
F	Front overhang	2,610 mm	2,830 mm
G	Wheel base	3,230 mm	3,230 mm
H	Ground clearance	400 mm	400 mm
I	Overall height (Cabin)	3,540 mm	3,540 mm
J	Dump angle	45 °	45 °
K	Overall width (with Bucket)	3,100 mm	3,100 mm
	Overall width (without Bucket)	2,850 mm	2,850 mm
	Rollback angle (Ground)	45 °	45 °
	Rollback angle (Carry)	48 °	54 °
	Clearance circle (Bucket)	14,205 mm	14,350 mm
	Turning radius (Center of outside tire)	6,267 mm	6,267 mm