

STANDARD EQUIPMENT

ISO Standard cabin
All-weather steel cab with 360° visibility
Safety glass windows
Rise-up type windshield wiper
Sliding fold-in front window
Sliding side window(LH)
Lockable door
Hot & cool box
Storage compartment & Ashtray
Cabin roof-steel cover
Radio / USB player
12 volt power outlet (24V DC to 12V DC converter)
Computer aided power optimization (New CAPO) system
3-power mode, 2-work mode, User mode
Auto deceleration & one-touch deceleration system
Auto warm-up system
Auto overheat prevention system
Automatic climate control
Air conditioner & heater
Defroster
Self-diagnostics system
Starting Aid (air grid heater) for cold weather
Centralized monitoring
LCD display
Engine speed or Trip meter/Accel.
Clock
Gauges
Fuel level gauge
Engine coolant temperature gauge
Hyd. oil temperature gauge
Warnings
Check engine
Overload
Communication error
Low battery
Air cleaner clogging
Indicators
Max power
Low speed/High speed
Fuel warmer
Auto idle
Door and cab locks, one key
Two outside rearview mirrors
Fully adjustable suspension seat with seat belt
Pilot-operated slidable joystick
Six front working lights (4 boom mounted, 2 front frame mounted)
Electric horn
Batteries (2 x 12V x 160 AH)
Battery master switch
Removable clean-out dust net for cooler
Automatic swing brake
Recurved reservoir tank
Fuel pre-filter
Boom holding system
Arm holding system
Track shoes (600mm, 24")
Track rail guard
Accumulator for lowering work equipment
Electric transducer
Lower frame under cover (Normal)

OPTIONAL EQUIPMENT

Fuel filler pump (35 L/min)
Beacon lamp
Single-acting piping kit (breaker, etc.)
Double-acting piping kit (clamshell, etc.)
Quick coupler
Travel alarm
Booms
6.15 m, 20' 2"
6.5 m, 21' 4"
6.5 m, 21' 4" Heavy Duty
8.6 m, 28' 3"
Arms
2.5 m, 8' 2"
3.2 m, 10' 6"
3.2 m, 10' 6" Heavy Duty
3.9 m, 12' 10"
4.3 m, 14' 1"
5.1 m, 16' 9"
Climate control
Air conditioner only
Heater only
Cabin ROPS (ISO 12117-2)
ROPS (Roll Over Protective Structure)
Cabin FOPS (ISO 10262 Level II)
FOPS (Falling Object Protective Structure)
Cabin guard-Front
Wire net
Fine net
Cabin lights
Cabin front window rain guard
Sun visor
Track shoes
Triple grousers shoe (700mm, 28")
Triple grousers shoe (750mm, 30")
Triple grousers shoe (800mm, 32")
Triple grousers shoe (900mm, 36")
Double grousers shoe (600mm, 24")
Double grousers shoe (700mm, 28")
Heavy duty track shoe (600mm, 24")
Heavy duty track shoe (700mm, 28")
Full track rail guard (3-piece track rail guard)
Lower frame under cover (Additional)
Pre-heating system, coolant
Tool kit
Operator suit
Rearview camera
Seat
Mechanical suspension seat with heater
Hi MATE (Remote Management System)
Fuel warmer
Air compressor
Precleaner
Cat walk

* Standard and optional equipment may vary. Contact your Hyundai dealer for more information. The machine may vary according to International standards.
 * The photos may include attachments and optional equipment that are not available in your area.
 * Materials and specifications are subject to change without advance notice.
 * All imperial measurements rounded off to the nearest pound or inch.



Head Office(Sales Office)
 14F, GLOBAL R&D CENTER, 477 BUNDANG SUSEO-RO, BUNDANG-GU, SEONGNAM-SI, GYEONGGI-DO, 13553, KOREA

Robex 380 LC-9SH

With Tier 2 Engine installed

* Photo may include optional equipment.



PLEASE CONTACT

Pride at Work

Hyundai Heavy Industries strives to build state-of-the-art earthmoving equipment to give every operator maximum performance, more precision, versatile machine preferences, and proven quality. Take pride in your work with Hyundai!



Robex 380LC-95H

Machine Walk-Around

Engine Technology

Proven / reliable, fuel efficient Hyundai D6AC-C engine
Low noise / Auto engine warm up feature / Anti-restart feature

Hydraulic System Improvements

New patented hydraulic control for improved controllability / Improved control valve design for added efficiency and smoother operation / New auto boom and swing priority system for optimum speed / New auto power boost feature for additional power when needed / Improved arm-in and boom-down flow regeneration system for added speed and efficiency

Pump Compartment

Industry-leading, powerful, reliable Kawasaki designed, variable volume in-line axial piston pumps
New compact solenoid block equipped with 4 solenoid valves, 1 EPPR valves, 1 check valve accumulator and pilot filter - controls 2 speed travel, power boost, boom priority, safety lock

Enhanced Operator Cab

Improved visibility

Enlarged cab with improved visibility
Larger right-side glass, now one piece, for better right visibility
Safety glass windows on all sides - less expensive than (polycarbonate) and won't scratch or fade
Closeable sunshade for operator convenience / Reduced front window seam for improved operator view

Improved Cab Construction

New steel tube construction for added operator safety, protection and durability
New window open/close mechanism designed with cable and spring lift assist and single latch release

Improved Suspension Seat / Console Assembly

Ergonomic joysticks with auxiliary control buttons for attachment use. Now with new sleek styling
New joystick consoles - now adjustable in height by way of dial at bottom
Adjustable arm rests - turn dial to raise or lower for optimum comfort

Advanced 7" Color Cluster

New Color LCD Display with easy to read digital gauges for hydraulic oil temperature, water temperature, and fuel. Simplified design makes adjustment and diagnostics easier. Also, new enhanced features such as rear-view camera are integrated into monitor.
3 power modes : (P) Power, (S) Standard, (E) Economy, 2 work modes : Dig & Attachment, (U) User mode for operator preference
Enhanced self-diagnostic features with GPS / satellite technology
One pump flow or two pump flow for optional attachment is now selectable through the cluster / New anti-theft system with password capability
Boom speed and arm regeneration are selectable through the monitor.
Auto power boost is now available - selectable (on/off) through the monitor.

RMS (Remote Management System) works through GPS/satellite technology to ultimately provide better customer service and support.

Undercarriage

Sealed track chain (urethane seals) / Standard track rail guard / Comfortable bolt-on steps
Large upper roller cut-outs for debris clean-out / Tapered side frames for debris clean-out / Grease-type track tensioner

*Photo may include optional equipment.

Preference

Operating a 9S Series is unique to every operator. Operators can fully customize their work environment and operating preferences to fit their individual needs.



*Photo may include optional equipment.

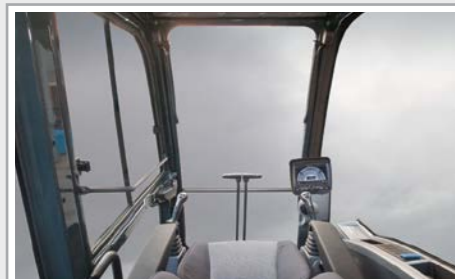

Wide Cabin with Excellent Visibility

The newly designed cabin was conceived for more space, a wider field of view and operator comfort. Special attention was given to a clear, open and convenient interior with plenty of visibility on the machine surroundings and the job at hand. This well balanced combination of precision aspects put the operator in the perfect position to work safely and securely.

Operator Comfort

In 9S Series cabin you can easily adjust the seat, console and armrest settings to best suit your personal operating preferences. Seat and console position can be set together and independent from each other. Other preference settings that add to overall operator comfort include the fully automatic high capacity airconditioning system and the radio / USB player.



Reduced Stress

Work is stressful enough. Your work environment should be stress free. Hyundai's 9S Series provides improved cab amenities, additional space and a comfortable seat to minimize stress to the operator. A powerful climate control system provides the operator with optimum air temperature. An advanced audio system with USB player, AM/FM stereo is perfect for listening to music favorites.



Operator - Friendly Cluster

The advanced new cluster with 7 inch wide color LCD screen and toggle switch allows the operator to select his personal machine preferences. Power and work mode selection, self diagnostics, optional rear-view camera, maintenance check lists, start-up machine security were integrated into the cluster to make the machine more versatile and the operator more productive.



Precision

Innovative hydraulic system technologies make the 9S Series excavator fast, smooth and easy to control.



*Photo may include optional equipment.

Computer Aided Power

The engine horsepower and hydraulic horsepower together in unison through the advanced CAPO(Computer Aided Power Optimization) system, flow for the job at hand. Operator can set their own preferences for boom or swing priority, power mode selection and optional work tools at the touch of a button.

The CAPO system also provides complete self diagnostic features and digital gauges for important information like hydraulic oil temperature, water temperatures and fuel level. This system interfaces with multiple sensors placed throughout the hydraulic system as well as hydraulic flow.

Power Mode

P (Power Max) mode maximizes machine speed and power for mass production. S (Standard) mode provides a reduced, fixed rpm for optimum performance and improved fuel economy. For maximum fuel savings and improved control, E (Economy) mode provides precise flow based on load demand. Three unique power modes provide the operator with custom power, speed and fuel economy.

Work Mode

The work mode allows the operator to select single flow attachments like a hydraulic breaker or bi-directional flow attachments like a crusher. Flow settings unique to each attachment can be programmed from within the cluster.

User Mode

Some jobs require more precise machine settings. Using the versatile U (User) mode, the operator can customize engine speed, pump output, idle speed and other machine settings for the job at hand.

Improved Hydraulic System



To achieve optimum precision, Hyundai redesigned the hydraulic system to provide the operator with super fine touch and improved controllability. Improved pump flow control reduces flow when controls are not being used to minimize fuel consumption.

Improved spool valves in the control valve are engineered to provide more precise flow to each function with less effort.

Improved hydraulic valves, precision-designed variable volume piston pumps, fine-touch pilot controls, and enhanced travel functions make any operator running a 9S

Series look like a smooth operator. Newly improved features include arm-in and boom-down flow regeneration, improved control valve technology and innovative auto boom and swing priority for optimal performance in any application.

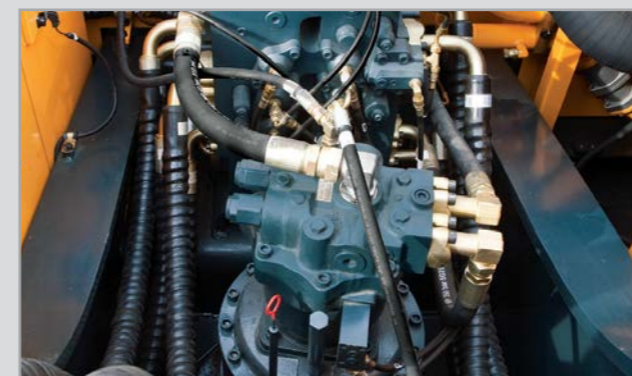

Auto Boom-swing Priority

This smart function automatically and continuously looks the ideal hydraulic flow balance for the boom and swing motions of the machine. The advanced CAPO system monitors the hydraulic system and adjusts its settings to maximize performance and productivity.

Performance

9S Series is designed for maximum performance to keep the operator working productively.

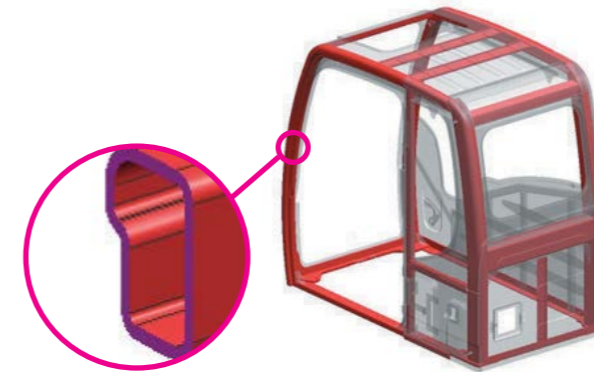

*Photo may include optional equipment.



Track Rail Guard & Adjusters

Durable track rail guards keep track links in place. Track adjustment is made easy with standard grease cylinder track adjusters and shock absorbing springs.



Structural Strength

The 9S Series cabin structure has been fitted with stronger but slimmer tubing for more safety and improved visibility. Low-stress, high strength steel is integrally welded to form a stronger, more durable upper and lower frame. Structural integrity was tested by way of FEM (Finite Elements Method) analysis and long-term durability tests. The optional ROPS(Roll Over Protective Structure) cab can be equipped to enhance operator safety.

HYUNDAI D6AC-C ENGINE

The six cylinders, 4 cycle, turbo-charged, charger air cooled engine is built for power, reliability, economy and low emissions.

A More Reliable Way To Reach Your Dream.

When you have a tough job to do, you need power precision and flexibility of Hyundai D6AC-C engine. It is built to withstand the toughest work environment. Bearings have more surface area to handle higher loads with greater durability. Reduced friction in the power cylinder means longer life and increased power output. From the structurally reinforced block to the stiffened gear housing, the D6AC-C is built stronger to last longer.

The D6AC-C engine is capable of reaching Tier 2 emission standards without electronic engine controls. It uses durable mechanical IN-LINE fuel injection system. You get a proven power plant that meets ecological concerns, without paying a premium for technology you don't need.

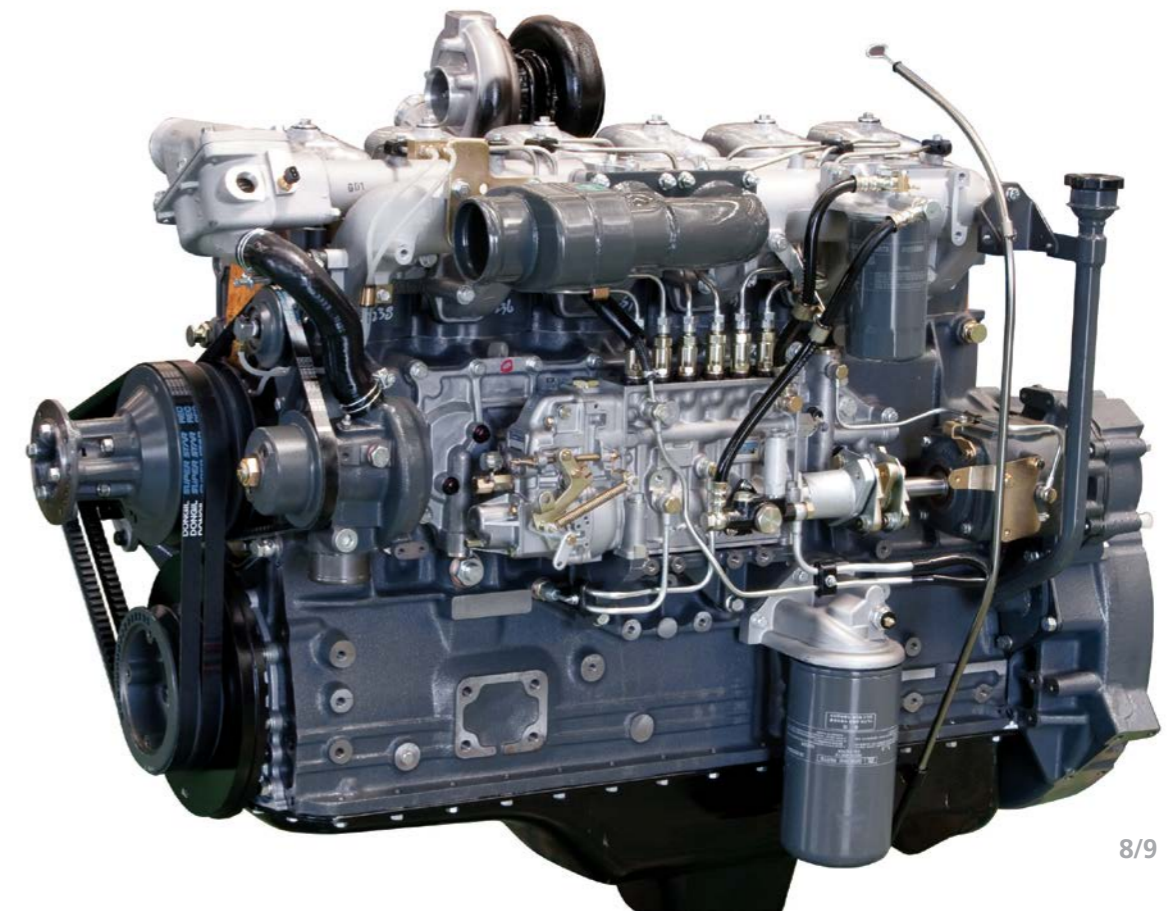

Profitability

9S Series is designed to maximize profitability through improved efficiencies, enhanced service features and longer life components.



*Photo may include optional equipment.

Fuel Efficiency

9S Series excavators are engineered to be extremely fuel efficient. New innovations like two-stage auto decel system and the new economy mode help to conserve fuel and reduce the impact on the environment.



Hi MATE (Remote Management System)

Hi MATE, Hyundai's proprietary remote management system, provides operators and dealer service personnel access to vital service and diagnostic information on the machine from any computer with internet access. Users can pinpoint machine location using digital mapping and set machine work boundaries, reducing the need for multiple service calls. Hi MATE saves time and money for the owner and dealer by promoting preventative maintenance and reducing machine downtime.

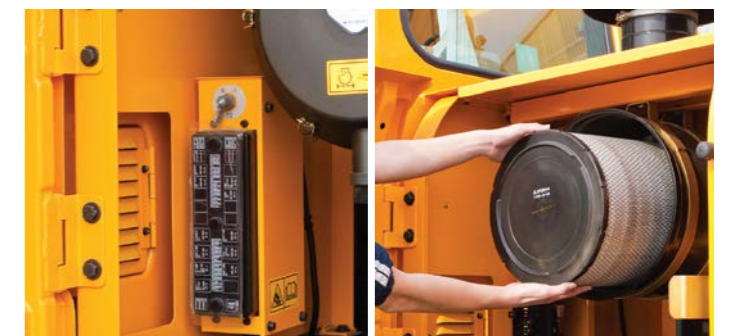
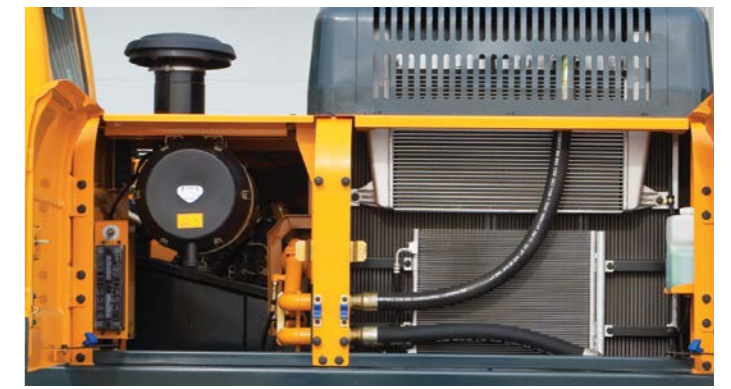

Easy Access

Ground-line access to filters, lube fittings, fuses, machine computer components and wide open compartments makes service more convenient on the 9S Series.



Long-Life Components

9S series excavators were designed with bushings designed for long-life lube intervals (250 hrs) & polymer shims (wear resistant, noise reducing), long-life hydraulic filters (1,000hrs), long-life hydraulic oil (5,000hrs), more efficient cooling systems and integrated preheating systems which extend service intervals, minimize operating costs and reduce machine down time.

Specifications

ENGINE

MODEL	HYUNDAI D6AC-C		
Type	Water cooled, 4 cycle Diesel, 6-cylinders in line, direct injection, turbocharged, charger air cooled, low emission		
Rated flywheel horsepower	SAE	J1995 (gross)	276 HP (206 kW) at 1,900 rpm
		J1349 (net)	261 HP (195 kW) at 1,900 rpm
	DIN	6271/1 (gross)	280 PS (206 kW) at 1,900 rpm
		6271/1 (net)	265 PS (195 kW) at 1,900 rpm
Max. torque	120 kgf.m (868 b.ft) / 1,400 rpm		
Bore X stroke	130 mm X 140 mm (9.56" X 10.3")		
Piston displacement	11,149cc (680 in ³)		
Batteries	2 X 12V X 160AH		
Starting motor	24V, 5.5 kW		
Alternator	24V, 70 Amp		

HYDRAULIC SYSTEM

MAIN PUMP	
Type	Variable displacement tandem-axis piston pumps
Rated flow	2 X 280 L/min (74.0 US gpm / 61.6 UK gpm)
Sub-pump for pilot circuit	Gear pump

Cross-sensing and fuel saving pump system.

HYDRAULIC MOTORS	
Travel	Two speed axial pistons motor with brake valve and parking brake
Swing	Axial piston motor with automatic brake

RELIEF VALVE SETTING	
Implement circuits	330 kgf/cm ² (4,690 psi)
Travel	360 kgf/cm ² (5,120 psi)
Power boost (boom, arm, bucket)	360 kgf/cm ² (5,120 psi)
Swing circuit	290 kgf/cm ² (4,125 psi)
Pilot circuit	40 kgf/cm ² (569 psi)
Service valve	Installed

HYDRAULIC CYLINDERS	
No. of cylinder bore X stroke	Boom: 2-160 X 1,500 mm (6.3" X 59.1")
	Arm: 1-170 X 1,760 mm (6.7" X 69.3")
	Bucket: 1-150 X 1,295 mm (5.9" X 51.0")
	Bucket : Ø160x1,295 ST * 6,150 mm (20' 2") Boom and 2,500 mm (8' 2") arm only

DRIVES & BRAKES

Drive method	Fully hydrostatic type
Drive motor	Axial piston motor, in-shoe design
Reduction system	Planetary reduction gear
Max. drawbar pull	32,000 kgf (70,550 lbf)
Max. travel speed(high) / (low)	5.0 km/hr (3.1 mph) / 3.1 km/hr (1.9 mph)
Gradeability	35° (70 %)
Parking brake	Multi wet disc

CONTROL

Pilot pressure operated joysticks and pedals with detachable lever provide almost effortless and fatigueless operation.

Pilot control	Two joysticks with one safety lever (LH): Swing and arm, (RH): Boom and bucket(ISO)
Traveling and steering	Two levers with pedals
Engine throttle	Electric, Dial type

SWING SYSTEM

Swing motor	Fixed displacement axial pistons motor
Swing reduction	Planetary gear reduction
Swing bearing lubrication	Grease-bathed
Swing brake	Multi wet disc
Swing speed	10 rpm

COOLANT & LUBRICANT CAPACITY

Refilling	liter	US gal	UK gal
Fuel tank	550	145.3	121.0
Engine coolant	52.0	13.7	11.4
Engine oil	27.3	7.2	6.0
Swing device-gear oil	8.0	2.1	1.8
Final drive(each)-gear oil	4.3	1.1	0.9
Hydraulic system(including tank)	410.0	108.3	90.2
Hydraulic tank	210.0	55.5	46.2

UNDERCARRIAGE

The X-leg type center frame is integrally welded with reinforced box-section track frame. The undercarriage includes lubricated rollers, idlers, track adjusters with shock absorbing springs and sprockets, and a track chain with double or triple grouser shoes.

Center frame	X - leg type
Track frame	Pentagonal box type
No. of shoes on each side	51 EA
No. of carrier roller on each side	2 EA
No. of track roller on each side	9 EA
No. of rail guard on each side	2 EA

OPERATING WEIGHT (APPROXIMATE)

Operating weight, including 6,500mm (21' 4") boom, 3,200mm (10' 6") arm, SAE heaped 1.62m³ (2.12 yd³) bucket, lubricant, coolant, full fuel tank, full hydraulic tank, and all standard equipments.

MAJOR COMPONENT WEIGHT	
Upperstructure	8,750 kg (19,290 lb)
Boom (with arm cylinder)	3,780 kg (8,330 lb)
Arm (with bucket cylinder)	2,010 kg (4,430 lb)

OPERATING WEIGHT			
Shoes		Operating weight	Ground pressure
Type	Width mm(in)	kg (lb)	kgf/cm ² (psi)
Triple grouser	600 (24")	38,450 (84,770)	0.69 (9.81)
	700 (28")	38,900 (85,760)	0.60 (8.51)
	750 (30")	39,125 (86,260)	0.56 (7.98)
	800 (32")	39,350 (86,750)	0.53 (7.54)
	900 (36")	39,800 (87,740)	0.48 (6.83)
Heavy Duty	600 (24")	38,840 (85,630)	0.69 (9.81)
	700 (28")	39,360 (86,770)	0.60 (8.53)
Double grouser	600 (24")	38,695 (85,310)	0.69 (9.81)
	700 (28")	39,195 (86,410)	0.60 (8.53)

BUCKETS

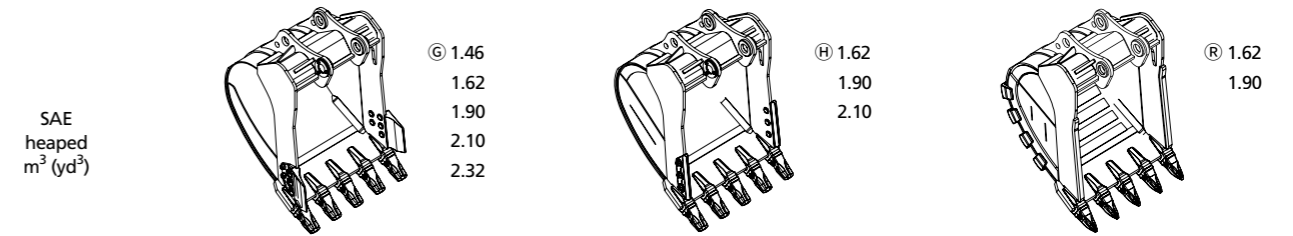

Capacity m ³ (yd ³)		Width mm (in)	Weight kg (lb)	Tooth EA	Recommendation mm (ft-in)						
SAE heaped	CECE heaped				6,150 (20' 2") Boom		6,500 (21' 4") Boom				8,600 (28' 3") Boom
					2,500 (8' 2") Arm	2,500 (8' 2") Arm	2,900 (9' 6") Arm	3,200 (10' 6") Arm	3,900 (12' 10") Arm	4,300 (14' 1") Arm	5,100 (16' 9") Arm
Ⓒ 1.46 (1.91)	1.28 (1.67)	1,370 (54")	1,430 (3,150)	4	●	●	●	●	○	■	▲
Ⓒ 1.62 (2.12)	1.42 (1.86)	1,480 (58")	1,530 (3,370)	5	●	●	●	○	■	■	-
Ⓒ 1.90 (2.49)	1.65 (2.16)	1,665 (66")	1,640 (2,450)	5	●	○	○	■	▲	▲	-
Ⓒ 2.10 (2.75)	1.84 (2.41)	1,800 (71")	1,720 (3,790)	5	○	■	■	■	▲	-	-
Ⓒ 2.32 (3.03)	2.02 (2.64)	1,950 (77")	1,830 (4,030)	6	■	■	▲	▲	-	-	-
Ⓗ 1.62 (2.12)	1.42 (1.86)	1,480 (58")	1,660 (3,660)	5	●	●	●	○	■	▲	-
Ⓗ 1.90 (2.49)	1.65 (2.16)	1,665 (66")	1,790 (3,950)	5	●	○	■	■	▲	▲	-
Ⓗ 2.10 (2.75)	1.84 (2.41)	1,800 (71")	1,880 (4,140)	5	○	■	■	▲	▲	-	-
Ⓘ 1.62 (2.12)	1.42 (1.86)	1,480 (58")	1,850 (4,080)	5	●	●	○	○	-	-	-
Ⓘ 1.90 (2.49)	1.65 (2.16)	1,665 (66")	1,990 (4,390)	5	○	○	■	■	-	-	-

- Ⓒ : General purpose
- Ⓗ : Heavy duty
- Ⓘ : Rock

- : Applicable for materials with density of 2,100 kg/m³ (3,500 lb/yd³) or less
- : Applicable for materials with density of 1,800 kg/m³ (3,000 lb/yd³) or less
- : Applicable for materials with density of 1,500 kg/m³ (2,500 lb/yd³) or less
- ▲ : Applicable for materials with density of 1,200 kg/m³ (2,000 lb/yd³) or less
- : Not Recommended

ATTACHMENT

Booms and arms are of all-welded, low-stress, full-box section design. 6,150 mm (20' 2"), 6,500 mm (21' 4"), 8,600 mm (28' 3"), boom and 2,500 mm (8' 2"), 2,900 mm (9' 6"), 3,200 mm (10' 6"), 3,900 mm (12' 10"), 4,300 mm (14' 1"), 5,100 mm (16' 9"), arms are available, Hyundai Bucket are all-welded, high-strength steel implements.

DIGGING FORCE

Boom	Length	mm (ft-in)	6,150 (20' 2")		6,500 (21' 4")				8,600 (28' 3")	Remarks
			Weight	kg (lb)	3,780 (8,330)				4,560 (10,050)	
Arm	Length	mm (ft-in)	2,500 (8' 2")		2,900 (9' 6")	3,200 (10' 6")	3,900 (12' 10")	4,300 (14' 1")	5,100 (16' 9")	
	Weight	kg (lb)	1,990 (4,390)		2,140 (4,720)	2,010 (4,430)	2,220 (4,890)	2,340 (5,160)	2,560 (5,640)	
Bucket digging force	SAE	kN	228.5 [249.3]		228.5 [249.3]	201.0 [219.3]	201.0 [219.3]	201.0 [219.3]	201.0 [219.3]	
		kgf	23,300 [25,420]		23,300 [25,420]	20,500 [22,360]	20,500 [22,360]	20,500 [22,360]	20,500 [22,360]	
		lbf	51,370 [56,040]		51,370 [56,040]	45,190 [49,300]	45,190 [49,300]	45,190 [49,300]	45,190 [49,300]	
	ISO	kN	259.9 [283.5]		259.9 [283.5]	228.5 [249.3]	228.5 [249.3]	228.5 [249.3]	228.5 [249.3]	
		kgf	26,500 [28,910]		26,500 [28,910]	23,300 [25,420]	23,300 [25,420]	23,300 [25,420]	23,300 [25,420]	
		lbf	58,420 [63,740]		58,420 [63,740]	51,370 [56,040]	51,370 [56,040]	51,370 [56,040]	51,370 [56,040]	
Arm crowd force	SAE	kN	184.4 [201.1]		164.8 [179.8]	152.0 [165.8]	135.3 [147.6]	124.5 [135.9]	109.8 [119.8]	[]: Power Boost
		kgf	18,800 [20,510]		16,800 [18,330]	15,500 [16,910]	13,800 [15,050]	12,700 [13,850]	11,200 [12,220]	
		lbf	41,450 [45,220]		37,040 [40,410]	34,170 [37,280]	30,420 [33,190]	28,000 [30,550]	24,690 [26,930]	
	ISO	kN	192.2 [209.7]		170.6 [186.1]	156.9 [171.2]	139.3 [151.9]	128.5 [140.1]	112.8 [123.0]	
		kgf	19,600 [21,380]		17,400 [18,980]	16,000 [17,450]	14,200 [15,490]	13,100 [14,290]	11,500 [12,550]	
		lbf	43,210 [47,140]		38,360 [41,840]	35,270 [38,480]	31,310 [34,160]	28,880 [31,510]	25,350 [27,650]	

Note: Boom weight includes arm cylinder, piping, and pin
Arm weight includes bucket cylinder, linkage, and pin

Dimensions & Working Range

R380LC-9SH DIMENSIONS

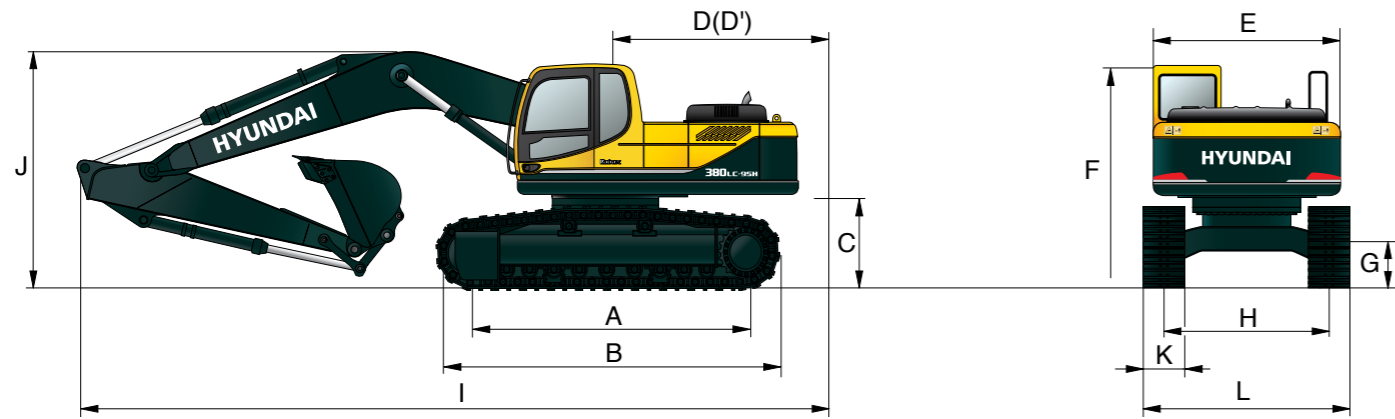

mm (ft-in)

Unit : mm (ft-in)

		Unit : mm (ft-in)									
A	Tumbler distance	4,340 (14' 3")	Boom length		6,150 (20' 2")	6,500 (21' 4")			8,600 (28' 3")		
B	Overall length of crawler	5,217 (17' 1")	Arm length		2,500 (8' 2")	2,500 (8' 2")	2,900 (10' 6")	3,200 (10' 6")	3,900 (12' 10")	4,300 (14' 1")	5,100 (16' 9")
C	Ground clearance of counterweight	1,295 (4' 3")	I Overall length		10,880 (35' 8")	11,240 (36' 11")	11,180 (36' 8")	11,120 (36' 6")	11,160 (36' 7")	11,110 (36' 5")	13,070 (42' 11")
D	Tail swing radius	3,425 (11' 3")	J Overall height of boom		3,760 (12' 4")	3,710 (12' 2")	3,540 (11' 7")	3,450 (11' 4")	3,880 (12' 9")	4,300 (14' 1")	4,910 (16' 1")
D'	Rear-end length	3,350 (10' 12")	K Track shoe width		600 (24")	700 (28")	750 (30")	800 (32")	900 (36")		
E	Overall width of upperstructure	2,980 (9' 9")	L Overall width		3,340 (10' 11")	3,440 (11' 3")	3,490 (11' 5")	3,540 (11' 7")	3,640 (11' 11")		
F	Overall height of cab	3,175 (10' 5")									
G	Min. ground clearance	550 (1' 10")									
H	Track gauge	2,740 (8' 12")									

Dimensions & Working Range

R380LC-9SH WORKING RANGE

Unit : mm (ft-in)

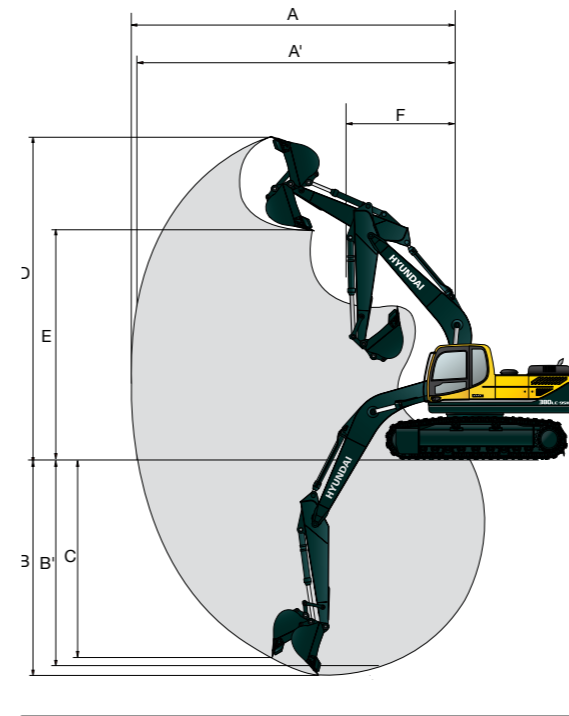

	Boom length	6,500 (21' 4")					8,600 (28' 3")
		6,150 (20' 2")	2,500 (8' 2")	2,900 (9' 6")	3,200 (10' 6")	3,900 (12' 10")	
Arm length	2,500 (8' 2")	2,500 (8' 2")	2,900 (9' 6")	3,200 (10' 6")	3,900 (12' 10")	4,300 (14' 1")	5,100 (16' 9")
A Max. digging reach	10,330 (33' 2")	10,720 (35' 2")	11,000 (36' 1")	11,250 (36' 11")	11,870 (38' 11")	12,380 (40' 7")	11,140 (36' 7")
A' Max. digging reach on ground	10,100 (33' 2")	10,490 (34' 5")	10,780 (35' 4")	11,040 (36' 3")	11,670 (38' 3")	12,180 (40' 0")	10,940 (35' 11")
B Max. digging depth	6,450 (21' 2")	6,820 (22' 5")	7,220 (23' 8")	7,520 (24' 8")	8,220 (27' 0")	8,620 (28' 3")	7,370 (24' 2")
B' Max. digging depth (8' level)	6,270 (20' 7")	6,640 (21' 9")	7,060 (23' 2")	7,360 (24' 2")	8,080 (26' 6")	8,490 (27' 10")	7,210 (23' 8")
C Max. vertical wall digging depth	5,490 (18' 0")	5,930 (19' 5")	5,970 (19' 7")	6,330 (20' 9")	7,040 (23' 1")	7,540 (24' 9")	6,360 (20' 10")
D Max. digging height	10,320 (33' 10")	10,590 (34' 9")	10,480 (34' 5")	10,570 (34' 8")	10,800 (35' 5")	11,360 (37' 3")	10,310 (33' 10")
E Max. dumping height	7,120 (23' 4")	7,370 (24' 2")	7,330 (24' 1")	7,410 (24' 4")	7,640 (25' 1")	8,160 (26' 9")	7,240 (23' 9")
F Min. swing radius	4,220 (13' 10")	4,530 (14' 10")	4,540 (14' 11")	4,450 (14' 7")	4,440 (14' 7")	4,460 (14' 8")	4,470 (14' 8")

Lifting Capacity

R380LC-9SH

Boom : 6.15 m (20' 2") / Arm : 2.5 m (8' 2") / Bucket : 1.62 m³ (2.12 yd³) SAE heaped / Shoe : 600mm(24") triple grouser

Load point height m (ft)	Load radius								At max. reach			
	3.0 m (10 ft)		4.5 m (15 ft)		6.0 m (20 ft)		7.5 m (25 ft)		Capacity		Reach	
											m (ft)	
9.0 m (30 ft)	kg								*7,580	*7,580	6.65	
	lb								*16,710	*16,710	(21.8)	
7.5 m (25 ft)	kg								*7,420	6,190	8.02	
	lb								*16,360	13,650	(26.3)	
6.0 m (20 ft)	kg					*8,590	*8,590	*6,510	*6,510	*7,460	4,980	8.88
	lb					*18,940	*18,940	*14,350	*14,350	*16,450	10,980	(29.1)
4.5 m (15 ft)	kg	*18,270	*18,270	*12,170	*12,170	*9,790	9,680	*8,620	6,560	7,480	4,350	9.38
	lb	*40,280	*40,280	*26,830	*26,830	*21,580	21,340	*19,000	14,460	16,490	9,590	(30.8)
3.0m (10 ft)	kg			*15,380	14,190	*11,300	9,030	*9,350	6,250	7,050	4,040	9.58
	lb			*33,910	31,280	*24,910	19,910	*20,610	13,780	15,540	8,910	(31.4)
1.5 m (5 ft)	kg			*17,740	13,080	*12,640	8,450	*10,060	5,940	7,010	3,980	9.52
	lb			*39,110	28,840	*27,870	18,630	*22,180	13,100	15,450	8,770	(31.2)
Ground	kg	*13,400	*13,400	*18,580	12,560	*13,410	8,060	10,120	5,710	7,360	4,170	9.19
Line	lb	*29,540	*29,540	*40,960	27,690	*29,560	17,770	22,310	12,590	16,230	9,190	(30.2)
-1.5 m (-5 ft)	kg	*21,020	*21,020	*18,170	12,420	*13,400	7,880	10,010		8,290	4,710	8.53
	lb	*46,340	*46,340	*40,060	27,380	*29,540	17,370	22,070		18,280	10,380	(28.0)
-3.0m (-10 ft)	kg	*22,960	*22,960	*16,580	12,540	*12,330	7,930	5,610		*8,180	5,950	7.47
	lb	*50,620	*50,620	*36,550	27,650	*27,180	17,480	12,370		*18,030	13,120	(24.5)
-4.5 m (-15 ft)	kg	*17,870	*17,870	*13,110	12,970							
	lb	*39,400	*39,400	*28,900	28,590							

Boom : 6.5 m (21' 4") / Arm : 2.5 m (8' 2") / Bucket : 1.62 m³ (2.12 yd³) SAE heaped / Shoe : 600mm(24") triple grouser

Load point height m (ft)	Load radius								At max. reach			
	3.0 m (10 ft)		4.5 m (15 ft)		6.0 m (20 ft)		7.5 m (25 ft)		Capacity		Reach	
											m (ft)	
9.0 m (30 ft)	kg									*6,820	*6,820	7.22
	lb									*15,040	*15,040	(23.7)
7.5 m (25 ft)	kg									*6,770	5,390	8.49
	lb									*14,930	11,880	(27.9)
6.0 m (20 ft)	kg					*7,970	*7,970	*7,480	6,600	*6,850	4,400	9.29
	lb					*17,570	*17,570	*16,490	14,550	*15,100	9,700	(30.5)
4.5 m (15 ft)	kg			*11,870	*11,870	*9,290	*9,290	*8,060	6,340	6,800	3,870	9.77
	lb			*26,170	*26,170	*20,480	*20,480	*17,770	13,980	14,990	8,530	(32.1)
3.0m (10 ft)	kg			*15,200	13,420	*10,870	8,630	*8,870	6,000	6,450	3,610	9.97
	lb			*33,510	29,590	*23,960	19,030	*19,550	13,230	14,220	7,960	(32.7)
1.5 m (5 ft)	kg			*17,480	12,430	*12,250	8,060	*9,650	5,690	6,420	3,570	9.91
	lb			*38,540	27,400	*27,010	17,770	*21,270	12,540	14,150	7,870	(32.5)
Ground	kg			*18,200	12,080	*13,060	7,730	9,870	5,480	6,740	3,750	9.59
Line	lb			*40,120	26,630	*28,790	17,040	21,760	12,080	14,860	8,270	(31.5)
-1.5 m (-5 ft)	kg	*17,830	*17,830	*17,860	12,060	*13,180	7,610	9,790	5,410	7,540	4,230	8.97
	lb	*39,310	*39,310	*39,370	26,590	*29,060	16,780	21,580	11,930	16,620	9,330	(29.4)
-3.0m (-10 ft)	kg	*22,850	*22,850	*16,580	12,250	*12,430	7,700			*7,850	5,260	7.97
	lb	*50,380	*50,380	*36,550	27,010	*27,400	16,980			*17,310	11,600	(26.1)
-4.5 m (-15 ft)	kg	*18,790	*18,790	*13,880	12,720					*7,110	*7,110	6.39
	lb	*41,420	*41,420	*30,600	28,040					*15,670	*15,670	(21.0)

Lifting Capacity

R380LC-9SH

Boom : 6.5 m (21' 4") / Arm : 3.2 m (10' 6") / Bucket : 1.62 m³ (2.12 yd³) SAE heaped / Shoe : 600mm(24") triple grouser

Load point height m (ft)	Load radius										At max. reach												
	1.5 m (5 ft)		3.0 m (10 ft)		4.5 m (15 ft)		6.0 m (20 ft)		7.5 m (25 ft)		9.0 m (30 ft)		Capacity		Reach								
															m (ft)								
9.0 m (30 ft)	kg													*5,950	*5,950	7.97							
	lb													*13,120	*13,120	(26.1)							
7.5 m (25 ft)	kg													*4,560	*4,560	9.12							
	lb													*10,050	*10,050	(29.9)							
6.0 m (20 ft)	kg													*6,620	*6,620	9.87							
	lb													*14,590	*14,590	(32.4)							
4.5 m (15 ft)	kg									*8,260	*8,260	*7,320	6,530	*4,450	*4,450	*6,190	3,550	10.32					
	lb									*18,210	*18,210	*16,140	14,400	*9,810	*9,810	*13,650	7,830	(33.9)					
3.0m (10 ft)	kg									*13,520	*13,520	*9,960	8,910	*8,240	6,150	*6,360	4,430	5,940	3,310	10.50			
	lb									*29,810	*29,810	*21,960	19,640	*18,170	13,560	*14,020	9,770	13,100	7,300	(34.4)			
1.5 m (5 ft)	kg									*16,390	12,870	*11,570	8,270	*9,170	5,790	*7,510	4,230	5,890	3,250	10.45			
	lb									*36,130	28,370	*25,510	18,230	*20,220	12,760	*16,560	9,330	12,990	7,170	(34.3)			
Ground	kg									*13,090	*13,090	*17,880	12,230	*12,690	7,820	*9,880	5,520	*7,070	4,090	6,130	3,380	10.14	
Line	lb									*28,860	*28,860	*39,420	26,960	*27,980	17,240	*21,780	12,170	*15,590	9,020	13,510	7,450	(33.3)	
-1.5 m (-5 ft)	kg	*13,720	*13,720	*17,520	*17,520	*18,150	12,020	*13,170	7,600	9,750	5,370								6,730	3,740	9.57		
	lb	*30,250	*30,250	*38,620	*38,620	*40,010	26,500	*29,030	16,760	21,500	11,840								14,840	8,250	(31.4)		
-3.0m (-10 ft)	kg	*17,880	*17,880	*22,800	*22,800	*17,430	12,080	*12,880	7,580	9,750	5,370								*7,730	4,490	8.65		
	lb	*39,420	*39,420	*50,270	*50,270	*38,430	26,630	*28,400	16,710	21,500	11,840								*17,040	9,900	(28.4)		
-4.5 m (-15 ft)	kg	*22,600	*22,600	*21,880	*21,880	*15,520	12,390	*11,510	7,790										*7,690	6,200	7.25		
	lb	*49,820	*49,820	*48,240	*48,240	*34,220	27,320	*25,380	17,170										*16,950	13,670	(23.8)		
-6.0 m (-20 ft)	kg									*11,410	*11,410												
	lb									*25,150	*25,150												

- Lifting capacity is based on ISO 10567.
- Lifting capacity of the Robex Series does not exceed 75% of the tipping load with the machine on firm, level ground or 87% of full hydraulic capacity.
- The load point is a hook located on the back of the bucket.
- (*) indicates the load limited by hydraulic capacity.

