

# HA30A/HA45A

Articulated Dump Truck

\* Photo may include optional equipment.



Head Office(Sales Office)  
14F, GLOBAL R&D CENTER, 477 BUNDANG SUSEO-RO, BUNDANG-GU, SEONGNAM-SI, GYEONGGI-DO, 13553, KOREA



**SERIES HA30A HA45A**

PLEASE CONTACT

**Net Weight**  
23,200 to 30,100kg

**Max Power**  
276 kW (370 HP) to 368 kW (493 HP)

**Body Volume**  
17.8 to 26.0 m<sup>3</sup>

**Max Payload**  
28,000 to 41,000 kg

# THE NEXT PIECE

## The new A-Series articulated dump trucks

Introducing the new Hyundai HA30A and HA45A, two new articulated dump trucks that fit perfectly alongside our other A-Series machines. Based on a proven design with 50 years heritage, they have many unique features that set them apart. A tandem rear axle and independent front wheel suspension make them more manoeuvrable with greater traction for increased productivity, safety and comfort. With a sloping chassis, ground level service access and one of the biggest cabins in the industry, our new machines are part of a range and reputation that just keeps growing.

# A

**SERIES HA30A HA45A**



# PRODUCTIVITY & PERFORMANCE – THE ULTIMATE ADT

Permanent 6-wheel drive, rear tandem axles and front-mounted turning ring, provide equal power and weight distribution for optimal operating performance. A sloping rear frame guides loads to the front, increasing traction and providing a lower centre of gravity for greater stability and fast and easy tipping of the body for increased productivity.

## Optimum operating performance

### Manoeuvrable ▶

The turning ring is located in front of the articulation point, ensuring equal weight distribution to the front wheels in all operating situations, including maximum turning. This enables you to use the limited slip differentials with only 45% locking value, ensuring drive to both front wheels without completely locking.

Our rear frame and body design, combined with the front-mounted differential makes for a compact ADT, resulting in a small turning radius and outstanding stability.

More contact points with the ground make the machine more stable while turning. This offers a safer and more comfortable ride.

### Tough terrain ▶

The tandem rear axle showcases a massive 40° rotation to give unbeatable performance, traction and ground engagement over rough ground. This helps increase productivity and fuel efficiency.

Independent front wheel suspension allows free movement up front so that obstacles don't affect the back suspension or axles.



Front and rear differentials are limited slip while longitudinal differential can be manually locked.



### Travel speed ▲

Up to 55 km/h travel speed and Tip-tronic gear shift provide smoother operation whilst maintaining maximum momentum. The truck can also be run in both automatic and manual gears.



### Load retention ▲

Adjustable hydraulic retarder keeps the machine's speed constant on downhills, without the support of service brakes.

A sloping chassis keeps more fluid or wet materials including gravel inside the tipping body.

An optional rear tailgate increases body capacity and improves load retention for greater working efficiency.



### Unloading ▲

The optional heated body prevents frozen material sticking to it, enabling quicker and easier unloading.

# RELIABILITY AND EFFICIENCY

Proven and reliable engines provide all the power you need, with excellent torque and low fuel consumption whilst meeting Stage V European regulation requirements. Other features combined with world-class components further increase efficiency and decrease cost of ownership.

*More than 50 years of manufacturing heritage means there are no compromises in machine design that could reduce overall quality.*



### Powerful and cost effective

Proven Scania Stage V engines deliver 276 kW (370 HP) to the HA30A and 368 kW (493 HP) to the HA45A, providing high torque at low rpm with low fuel consumption.



## Intelligent design for improved economy

### Suspension ▼

Our self-leveling, hydro-gas front suspension system provides outstanding performance in rough terrain, especially when the machine is empty. It can also be adjusted to match changing working conditions.

### Differential and driveline ▼

Our design has one rear differential and a simple driveline, resulting in less moving parts for easier and lower cost maintenance.



### Payload ▶

Our standard real-life payload and load count meter provide both operator and owner with an immediate productivity report. External indication lights on the HA45A help load the body more efficiently.

### Compact ▶

With a less than 3-metre width, the HA30A can be easily moved from one site to another. And thanks to the compact design of both machines, a shorter low loader can be used.



# COMFORTABLE AND ERGONOMIC

A spacious cab and easy-to-use controls are essential for optimum operator comfort and productivity. Hyundai ADTs have all that and more, providing the perfect office environment for long hours working in some of the toughest conditions.

## Comfort for efficient operation

### LCD display ▶

A convenient 7" LCD colour display panel shows all the important control and safety information including that from a rear-view camera, real-life payloadmeter with external light indication on the HA45A and body tip boost button.



### Hoist lever ▼

An electronically managed body hoist lever is easy to operate with fingertip control. It incorporates a higher body up speed and an automatic body down feature, with soft touch, to keep you safe at all times.



### Convenience

A radio as standard supports all modern features including MP3, DAB and Bluetooth.

There are plenty of storage spaces and extra room designed to fit a cool or hot box. An additional 12V power supply is also provided.

Just 1 key locks and unlocks all the doors and also starts the engine.

Electrically heated and adjustable mirrors are optional available.



*Our spacious ROPS/FOPS cab is equipped with climate control and a high-quality operator seat with air suspension and armrest, for greater operator comfort.*

### Seat ▲

High-comfort air-suspension seat because a highly comfortable seat means a lot to every operator, we provide an air-suspension seat with armrest as standard.

### Focus ▶

Precise steering, good visibility and low noise levels, provide additional comfort and quiet.

The cab is mounted on a special rubber suspension to reduce vibration and conduction of noise into the cab.



# FULLY EQUIPPED FOR YOUR SAFETY

Safety is paramount on any worksite and both Hyundai ADTs come with many important features that provide all operators with greater confidence and peace of mind. Easier front access to the cab, superb visibility and overall machine stability come as standard.

*Easy cab access from the front, fenders and hand rails, plus superior machine stability, all provide greater safety.*



### Dumping ▲

Automatic over centre of gravity feature slows down the body hoist system, if it senses material stuck to the body when dumping.



### Parking brake ▲

Standard hydraulic transmission retarder and hydraulically activated mechanical parking brake add peace of mind.

### Short front frame ▶

The short front frame is designed to handle obstacles better and drive inertia along with the turning direction. This greatly improves safety when turning in tight corners.

### Visibility ▶

A sloping hood design provides the operator with an excellent view.



# SIMPLE SERVICING INCREASES UPTIME

Hyundai ADTs have been designed with longer lasting parts and easier servicing and maintenance, to save time and reduce costs. After all, less downtime means more time working and ultimately more time earning money.



### ◀ Convenient access

Easy ground level access to key service areas like diesel and Adblue® filling points and filters.



Multifunctional service and maintenance display makes it easy to check transmission oil level, plus hydraulic and electronic components.



### Less wear and tear ▲

Equal weight distribution ensures the same load on every tyre and so, less wear but greater traction.

Oil-cooled wet discbrakes with a lifetime of up to 15,000 hours.

New steel bearings last at least 12,000 hours.

*Auto grease system as standard on all machines, ensures correct lubrication to vital components.*



*A simplified cab tilt gives easy service access to the machine.*

*One rear differential and a far simpler driveline means less moving parts, for easier and more economical maintenance.*

# TAKE THE TOUR!

# A

**SERIES HA30A HA45A**



## Productivity & Efficiency

- Powerful Scania Stage V engines
- Permanent 6-wheel drive
- Rear tandem axles
- Front-mounted turning ring
- Equal power and weight distribution
- Limited slip differentials
- Independent front wheel suspension
- Sloping chassis design
- Adjustable hydraulic retarder
- Heated body **OPTION**
- Compact rear frame and body

## Comfort

- Spacious ROPS/FOPS cab
- Climate control & air suspension seat
- Precise steering
- Low noise levels
- Convenient 7" LCD colour display panel
- Electronically managed body hoist lever
- Suspended mounted cab
- Extra storage space
- Electric mirrors **OPTION**
- 1 key to unlock and start engine

## Serviceability

- Simplified cab tilt gives easy service access
- Ground level access to key service areas
- Oil-cooled wet disc brakes with up to 15,000 hour life
- Steel bearings lasting at least 12,000 hours
- Auto grease system as standard
- One rear differential and simpler driveline
- Equal weight distribution for less tyre wear
- Multifunctional service and maintenance display

## Safety

- Easy front cab access from the front
- Fenders and hand rails
- Superior machine stability
- Sloping hood design for greater visibility
- Hydraulic transmission retarder
- Hydraulically activated mechanical parking brake
- Short front frame to handle obstacles better
- Automatic over centre of gravity feature

# HA30A / HA45A SPECIFICATIONS

SPECIFICATIONS	HA30A	HA45A
<b>ENGINE</b>		
Maker / Model	Scania DC 9	Scania DC 13
Type	Water-cooled, diesel engine with turbo charger and air-to-air intercooler	
Aftertreatment System	VGT / DOC / DPF / SCR	
Power Rating ISO 3046 / ISO 14396 @ 2100 rpm	276 kW (370 HP) / 270 kW (362 HP)	368 kW (493 HP) / 360 kW (483 HP)
No. of Cylinders	5 (in line)	6 (in line)
Gross Torque	1876 Nm @ 1,400 rpm	2476 Nm @ 1,400 rpm
Displacement	9.3 litres	12.7 litres
Bore Diameter x Stroke	130 x 140 mm	130 x 160 mm
Air Filter	2-stage (main + safety), dry type	
Emissions	Complies with Stage V of emission regulation (EU) 2016/1628	
<b>ELECTRICAL SYSTEM</b>		
Voltage	24 V	
Battery	2 x 12 V	
Battery Capacity	2 x 105 Ah	
Starter Motor	6 kW	
Alternator	24 V / 100 A	
<b>DRIVETRAIN</b>		
Torque Converter	Lock up function in all gears	
Transmission	Electronically-controlled automatic transmission with retarder, Full-time 6 x 6 drive with two transverse differentials and one longitudinal Inter-axle longitudinal, Torque-proportioning differential, integrated into the ZF transmission	
Front Axle Transverse Differential	Limited-slip diff lock with 45% locking ratio mounted directly at transmission	
Rear Axle Transverse Differential	Limited-slip diff lock with 45% locking ratio	
Torque Distribution (100% Lockable)	1/3 to the front axle, 2/3 to the rear axle	

SPECIFICATIONS	HA30A	HA45A
<b>TRANSMISSION</b>		
Maker / Model	ZF 8 EP320	ZF 8 EP420
Travel Speed - Forward		
1st	6 km/h	5 km/h
2nd	8 km/h	8 km/h
3rd	11 km/h	11 km/h
4th	16 km/h	16 km/h
5th	23 km/h	23 km/h
6th	32 km/h	32 km/h
7th	45 km/h	45 km/h
8th	55 km/h	55 km/h
Travel Speed - Reverse		
1st	6 km/h	5 km/h
2nd	8 km/h	8 km/h
3rd	11 km/h	11 km/h
4th	16 km/h	16 km/h
Front Hubs	Kessler	
Rear Axle + Hubs	Kessler	
Rear Tandem	Hyundai (in house)	
<b>BRAKES</b>		
Service Brakes	Dual circuit braking system acting on all six wheels, all hydraulic-operated brakes with enclosed oil-cooled wet multiple discs on four hubs (braking force distributed to two hubs by tandem gear wheels).	
Parking Brake	Spring actuated mounted on driveline shaft	
Max. Gradient, Parking Brake	15°	
Retarder	Automatic transmission retarder standard	
Brake System	Complies with ISO3450	
<b>STEERING SYSTEM</b>		
Cylinder	Two double-acting	
Standard	The steering is approved according to ISO 5010	
Max. Steering Angle	45°	
Emergency Steering	Ground-driven emergency steering pump	
<b>CABIN</b>		
ROPS / FOPS cabin meet ISO 3471 and ISO 3449		
Hand and arm vibrations are less than 2.5 ms <sup>2</sup> (ISO 5349-2)		
Whole body vibration is less than 0.5 ms <sup>2</sup> (ISO 2631-1)		
<b>AIR CONDITIONING SYSTEM</b>		
The air conditioning system contains Fluorinated greenhouse gas refrigerant R134a (Global Warming Potential = 1430). The system contains 2.0 kg of refrigerant representing a CO <sub>2</sub> equivalent of 2.86 metric tonnes.		

SPECIFICATIONS	HA30A	HA45A	
<b>HYDRAULIC SYSTEM</b>			
Type	1 variable displacement piston pump for steering, tipping, cooling fan, brakes & auxiliaries		
Maximum Pump Output	305 l/min @ 2,100 rpm		
Filtration	return flow filter		
Main Safety Valve Pressure Tipping	280 bar		
Main Safety Valve Pressure Steering Circuit	210 bar		
Tilt Cylinders	Single stage, double-acting		
Tipping Time Raise	12 secs	10 secs	
Tipping Time Lower	10 secs	10 secs	
<b>BODY</b>			
Body Volume (Without Tailgate)	16.8 m <sup>3</sup>	24.4 m <sup>3</sup>	
Material	Hardened abrasion-resistant steel plates (400 HB)		
Body Tipping Angle	70°		
Level Capacity (with / without tailgate)	14.2 m <sup>3</sup> / 13.6 m <sup>3</sup>	20.4 m <sup>3</sup> / 19.6 m <sup>3</sup>	
Heaped capacity (with / without tailgate)	17.8 m <sup>3</sup> / 16.8 m <sup>3</sup>	26.0 m <sup>3</sup> / 24.4 m <sup>3</sup>	
<b>TYRES</b>			
Standard	23.5R25 **	29.5R25 **	
Optional	750/65R25	875/75R29	
<b>WEIGHTS</b>			
Empty	Front Axle	12700 kg	14200 kg
	Rear Axle	10500 kg	15900 kg
Net Weight	23200 kg	30100 kg	
Max. Admissible Axle Load	Front Axle	15900 kg	22100 kg
	Rear Axle	35300 kg	49000 kg
Max. Admissible Total Weight	51200 kg	71100 kg	
Payload	28 metric ton / 31 short ton	41 metric ton / 45 short ton	
<b>POWER TO WEIGHT RATIO</b>			
Empty	11.9 kW/t	12.2 kW/t	
Loaded	5.4 kW/t	5.2 kW/t	
<b>SERVICE REFILL CAPACITIES</b>			
Engine oil	35 l	45 l	
Fuel tank	360 l	500 l	
Def/Adblue®	70 l	70 l	
Engine coolant	45 l	50 l	
Transmission	68 l	69 l	
Hub front (2x)	11 l	9,6 l	
Front differential	9,4 l	9,4 l	
Tandem housing, rear differential and hubs	145 l	228 l	
Brake cooling tank	15 l	15 l	
Hydraulic system	75 l	85 l	
Hydraulic tank	63 l	63 l	
Windscreen washer tank	4,5 l	4,5 l	

SPECIFICATIONS	HA30A	HA45A	
<b>GROUND PRESSURE</b>			
Tyres	Standard tyres with 15% sinkage		
Unloaded	Front Axle	122 kPa	94 kPa
	Rear Axle	52 kPa	52 kPa
Loaded	Front Axle	162 kPa	139 kPa
	Rear Axle	170 kPa	161 kPa
<b>ARTICULATION HINGE AND CHASSIS</b>			
Articulation hinge	Articulation hinge with forward-mounted large dimensioned turning ring		
Chassis	Heavy duty design, box type welded frames; 7° sloping rear frame design		
<b>SUSPENSION</b>			
Front	Semi-independent, self-levelling hydro-gas suspension, manually adjustable		
Rear	Free-swinging tandem housing		
<b>NOISE</b>			
Guaranteed noise level presented below can be differed depending on a range of factors such as operating condition, speed of a cooling fan, types of engine and so forth. Hearing protection shall be necessary if an operator is working in the improperly maintained cabin or exposed to a noisy environment by leaving doors and/or windows open.			
With cooling fan speed at maximum value:			
Operator Sound Pressure Level (ISO 6396:2008)	72 dB(A)		
Exterior Sound Power Level (ISO 6395:2008)	108 dB(A)		

\*Distance of 15 m, moving forward in second gear ratio

# DIMENSIONS

## DIMENSIONS

All dimensions are approximate.

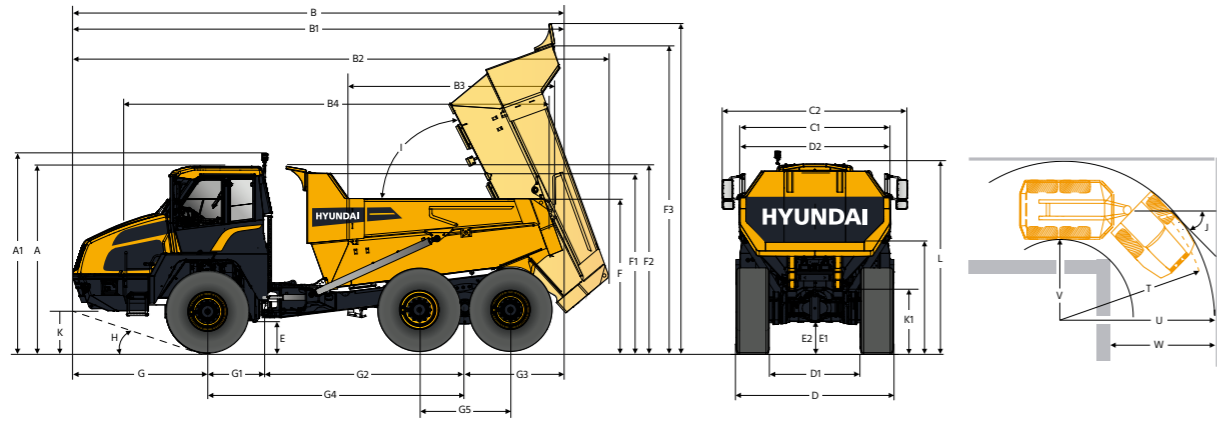

Unit: mm

Description	HA30A	HA45A
A Transport position / cab height	3604	3850
A1 Rotating beacon	3836	4050
B Overall w/o tailgate	9515	10633
B1 Overall with tailgate	9555	10673
B2 Overall body tipped	10405	11405
B3 Overloading height	3800	4360
C Over outside front tyre 23.5R25 / 29.5R25	3000	3475
C* Over outside front tyre 750/65R25 / 875/75R25	3208	3630
C1 Over mudguard	2860	3400
C2 Over mirror operating position	3499	3990
D Over outside rear tyres 23.5R25 / 29.5R25	3000	3475
D* Over outside rear tyres 750/65R25 / 875/75R25	3208	3630
D1 Between inner tyres	1740	1900
D2 Over body	2895	3395
E Ground clearance art. hinge	568	643
E1 Ground clearance front axle	529	625
E2 Ground clearance rear axle	540	691
E3 Ground clearance body fully tipped	619	763
F Overloading	2946	3355
F1 Body w/o rock guard	3436	3865
F2 Body with rock guard	3572	4001
F3 Body fully tipped w/o rock guard	5820	6755
F4 Body fully tipped with rock guard	6240	7170
F5 Body tip	2100	2390
G Front axle centre to machine front	2605	2818
G1 Front axle centre to art. hinge	1200	1275
G2 Art. hinge to rear axle centre	3800	4150
G3 Rear axle centre to body tip	1910	2390
G4 Front axle centre to rear axle centre	5000	5425
G5 Wheelbase rear axle	1771	1960
H Approach angle front	22.5°	26.7°
I Max. body tip angle		70°
J Max. steering angle		45°
K Front tie down height	874	1063
K1 Rear tie down height	1180	1300
L Load height (SAE 2 : 1)	3600	4100
V Inner turning radius	3995	4215
U Outer turning radius	8100	8920
T Outer wheel turning radius	8065	8880
W Corridor width	5280	5940

# STANDARD/OPTIONAL EQUIPMENT

	HA30A	HA45A
<b>ENGINE</b>		
Exhaust brake (in combination with hydraulic retarder)	●	●
Centrifugal air-precleaner	○	○
Electrical engine heater 220V	○	○
Fast fill refuelling system	○	○
Electric diesel refuelling pump	○	○
<b>ELECTRICAL SYSTEM</b>		
Head, position, turn, brake and rear lights	●	●
Hazard lights	●	●
Headlights LED	○	○
Work light kit (rear and front)	○	○
Work light kit (rear and front) LED	○	○
License plate light	○	○
Horn	●	●
Windshield wiper with interval + washer	●	●
Cigarette lighter	●	●
12V and USB charging point	●	●
Radio/MP3 and Bluetooth	●	●
CB radio preparation kit	○	○
Electrically adjustable & heated mirrors	○	○
Master switch	●	●
<b>MAIN DISPLAY</b>		
Fuel & DEF level	●	●
Engine coolant & transmission oil temperature	●	●
Speedometer & tachometer	●	●
Vehicle angle	●	●
Transmission status	●	●
Payload meter	●	●
Time & outside temperature	●	●
<b>CENTRAL INDICATION AND WARNING LAMPS</b>		
Indicator lamps grouped for all vital functions	●	●
Warnings integrated	●	●
<b>ELECTRONIC SYSTEM</b>		
Tip lever with button to increase engine rpm	●	●
Gradient meter with anti-flip-over protection system	●	●
Body height limitation	●	●
Payload meter & cycle counter	●	●
Overload protection system with external light bar	-	●
Auto engine shut off function	●	●
Speed limitation	○	○
<b>DRIVELINE</b>		
Full automatic transmission	●	●
Torque converter with automatic lock up clutch	●	●
Transmission retarder brake	●	●
Two circuit, wet disc brake acting on all 6 wheels	●	●
Brake cooling system	●	●
<b>TYRE OPTIONS</b>		
Earthmoving E3	●	●
Quarry E4	○	○
Wide bead (low ground pressure) tyres	○	○
Tyre pressure monitoring system (may not be available with all tyres)	○	○
Spare wheel	○	○

	HA30A	HA45A
<b>CABIN INTERIOR</b>		
Air suspended & heated operator seat SEARS	●	●
Armrest at operator seat	●	●
Headrest at operator seat	●	●
Safety belt with alarm	●	●
High-comfort seat (vertical and longitudinal suspension) GRAMMER	○	○
Instructor seat with safety belt	●	●
Interior light	●	●
Adjustable steering column	●	●
Electronic climate control	●	●
2-stage cabin fresh air filtration	●	●
HEPA cabin filter	○	○
Webasto heating system (heat up the cooling system)	○	○
Retractable roller sunblind	●	●
Tinted safety glass	●	●
Sliding window (left & right side)	●	●
Mirrors	●	●
Protection for rear window	●	●
Storage room	●	●
<b>SAFETY</b>		
Emergency steering, ground-driven	●	●
Rear-view camera	●	●
Hammer & belt cutter for emergency escape	●	●
Hand rails on the fenders	●	●
Anti-slip steps & platform	●	●
Emergency shutdown switch	●	●
Wheel chock	●	●
Fire extinguisher	○	○
First aid kit	○	○
Beacon lamp fix or foldable LED	○	○
Light bar LED	○	○
Seat belt green warning light	○	○
Blue or orange flashing reverse light	○	○
Back up alarm	●	●
White noise back up alarm	○	○
<b>BODY</b>		
Body prepared for exhaust heating	●	●
Body exhaust heating kit	○	○
Tailgate kit	○	○
Body lining kit	○	○
Body extension	○	○
<b>OTHER</b>		
Front wheel independent suspension, manual adjustable	●	●
Mud flaps	●	●
Towing hook, front and rear	●	●
Articulation joint lock	●	●
Rear lamp guard	○	○
HYUNDAI HiMate telematic system	●	●
Customized paint	○	○
<b>SERVICE</b>		
Automatic lubrication system	●	●
Cab tilting system	●	●
Artic oil & grease kit	○	○
Tool kit	○	○
Spare parts kit	○	○

● : Standard  
○ : Option  
- : Not available

\* Standard and optional equipment may vary. Contact your Hyundai dealer for more information. The machine may vary according to international standards.

\* The photos may include attachments and optional equipment that are not available in your area.

\* Materials and specifications are subject to change without advance notice.