

HL970A

With EU Stage V Engine installed

* Photo may include optional equipment.



Head Office(Sales Office)
14F, GLOBAL R&D CENTER, 477 BUNDANG SUSEO-RO, BUNDANG-GU, SEONGNAM-SI, GYEONGGI-DO, 13553, KOREA

PLEASE CONTACT

Gross Power
325 HP (242 kW) / 2,100 rpm

Net Power
322 HP (240 kW) / 2,100 rpm

Bucket Capacity
4.2 ~ 5.2 m³

Operating Weight
24,700 kg (54,455 lb)

WHAT'S NEWEST AND BEST

THE BEST PRODUCTIVITY AND FUEL EFFICIENCY

- EU STAGE V Engine
- Eco Report
- Smart Power Mode
- 5 Speed Lock Up Clutch **Option**
- Hydraulic Differential Lock **Option**
- ICCO (Intelligent Clutch Cut Off)
- Automatic Engine Shut Down
- Optimized Power Matching

ULTIMATE DURABILITY

- Unified Control Valve
- Enhanced Rear Axle Capacity
- Axle Oil Cooling System **Option**
- Thermostat for Transmission Cooling **Option**
- High Quality Hydraulic Hose
- Optimized Drive Shaft

EASY CONTROL AND COMFORTABLE OPERATION

- Electric Adjustable Heated Mirror **NEW**
- Fully Adjustable Seat and Armrest
- Remote Door Control **Option**
- Air Compressor **Option**
- Auto Greasing System **Option**
- Ride Control **Option**
- Full Sound-Proofed Spacious Cabin
- Wide Touch Screen Monitor
- Centralized Cluster
- Soft end Stop
- Weighing System
- Bucket Angle Display **NEW**

THE ULTIMATE SAFE ENVIRONMENT

- Seat Belt Warning Alarm
- Emergency Stop
- Radar **Option**
- AAVM+ **NEW** **Option**
(Advanced Around View Monitoring)
- See-Through Bucket **NEW** **Option**

SERVICEABILITY AND TELEMATICS

- Unnecessary Regular DPF Cleaning Interval
- ECD(Engine Connected Diagnostics)
- Fully Openable Engine Hood
- Hi MATE **Option**
- Easy Filter Replacement
- Wide Core & Fin Radiator
- Longer Lasting Filter
- Integrated Mudguard **NEW**





THE BEST PRODUCTIVITY AND FUEL EFFICIENCY

The new HYUNDAI HL970A with new engine technologies is satisfying the most strict environmental emission regulation in the world and A series in wheel loader have a number of new features that contribute to overall fuel and also production efficiency

FUEL SAVINGS

up to **5%**
V-type loading cycle
(Compared to Power mode)



Smart Power Mode

Smart Power mode reduces fuel consumption by adjusting the engine speed in heavy load work like digging. The key point of this function is not only saving fuel with same performance as Power mode but also making good balance between traction force and breakout force.



5 Speed Lock Up Clutch **Option**

By using of 5 Speed & lock up clutch, now operator can enjoy both the reduction of Fuel consumption and various of use in gears depends on the working condition. (2nd ~ 5th Gear Locking)



Hydraulic Differential Lock **Option**

Hydraulic differential lock has the advantages of both improving productivity and less fuel consumption by preventing tire slip during the operation.

Engagement-Manual / Auto
(100% Traction with tire slip)



ICCO (Intelligent Clutch Cut Off)

By selecting of 'H-Mode' among clutch cut-off selections, ICCO will be engaged for both less power loss in torque converter and lower heat generation on brake sides.

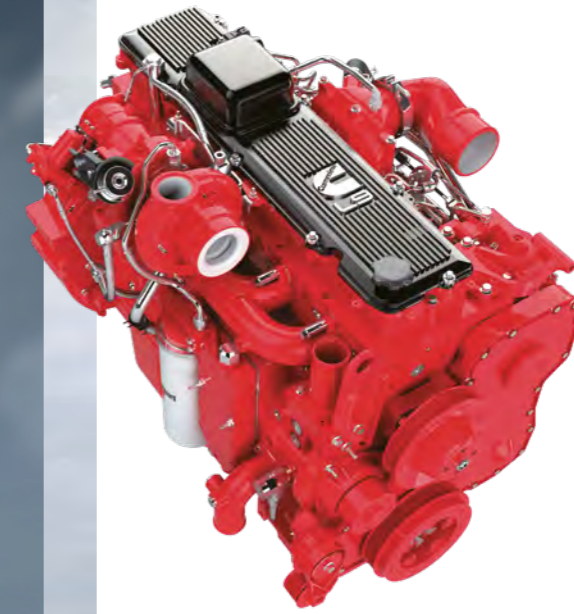
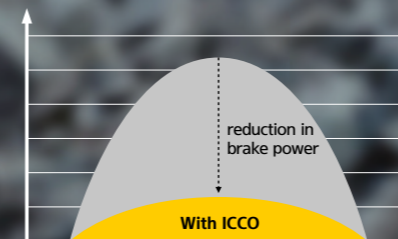

EU Stage V Engine

'Cummins L9' engine meeting Euro Stage V emission regulations is designed for maximum productivity and fuel efficiency.

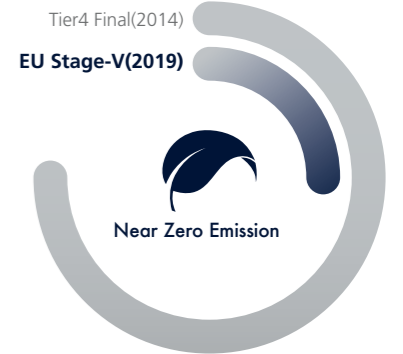

Automatic Engine Shut Down

Adjustable 'Automatic engine shut down' significantly reduces idle time, overall operating hours and fuel consumption.

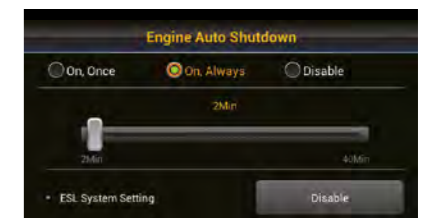

Eco Report

Eco report shows the wheel loader's inefficient operation status in order to improve operator's improper working habit.

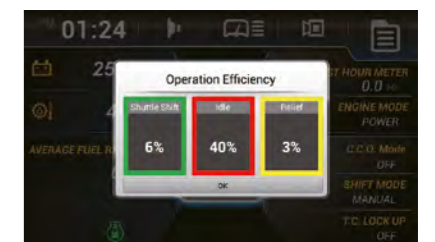

Optimized Power Matching

For maximum operational efficiency, the engine is designed to achieve high torque in the low RPM range. Change an engine rpm at peak torque to more low - lower rpm section also.

Photo may include optional equipment.

Unified Control Valve

HL900A Series improved hydraulic system. Unified control valve system removes the hydraulic hose connected with each valve and has fewer leak points. Because MCV is integrated with ride control valve and EPPR valve.

Enhanced Rear Axle Capacity

HL970A applied larger capacity axle than the previous series. It offers more reliable performance and longer durability.



Axle Oil Cooling System Option

Axle oil cooling system prevents overheating of axle oil caused by frequent braking and high-load work.

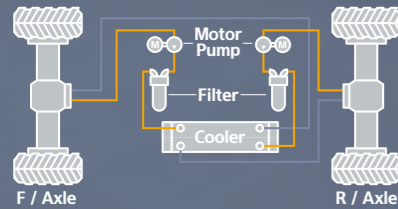

Thermostat for Transmission Cooling Option

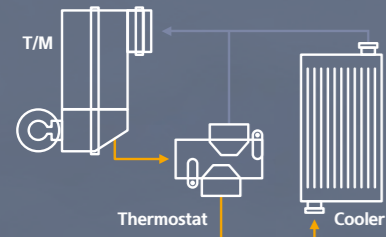

High Quality Hydraulic Hose

High quality hydraulic hoses increased durability and product life cycle.



Optimized Drive Shaft

Through thorough verification, the optimized drive shaft makes the HL970A Wheel Loader more durable.



ULTIMATE DURABILITY

The true value of the HL970A, which is now far more powerful, is revealed in tough working environments. With the high-strength design structure and enduring system proven by rigorous road tests at various work sites, Hyundai wheel loaders can perform any high-load work to maximize productivity.



Air Compressor **Option**

Air Compressor will be used for cleaning inside the cabin and for operator self-cleaning.



Full Sound-Proofed Spacious Cabin

State-of-the-art noise reduction technology of the HL970A ensures maximum silence(70dB) in the same category of equipment, promising more silent and more pleasant interior space.



Remote Door Control **Option**

Remote door control allows operators to open the cabin door remotely. This system was developed for the convenience and safety of the operator.



Wide Touch Screen Monitor

The seven-inch capacitive-type display (like a smart phone display) provides excellent legibility.



Centralized Cluster

With a centralized cluster, operator can see at a glance all the states of wheel loader.



Weighing System

The HL970A further improves work precision with additional weight calibration. The automatic/manual cumulative weighing function greatly enhances operating efficiency. Icons displaying weighing errors and the two-color weight value indication on the monitor enable accurate weighing to support efficient production management.



Soft End Stop

When an attachment reaches at the end stroke, it gives operator enormous shock especially for Boom up. This function gives shock free operation by reducing the speed of attachment near the end stroke. It can be selected on/off through Monitor.



Electric Adjustable Heated Mirror **NEW**

The electrically adjustable heated mirrors can be controlled from inside the cabin with a switch, offering angle adjustment and a heating function to enhance operator convenience.



Fully Adjustable Seat and Armrest

This suspension will be applied for minimizing an operator's fatigue.



Ride Control **Option**

Ride control system reduces operator fatigue and material spillage during operation. An accumulator helps to minimize shock, giving the operator a much smoother ride.



Auto Greasing System **Option**

Auto greasing system is designed to automatically lubricate when it is needed. Uniform application of lubricant ensures that the lubrication points always have the correct amount of grease.



EASY CONTROL AND COMFORTABLE OPERATION

The HL970A is optimized to enable operators to access accurate equipment data in a timely manner. This feature is more important in tough working environments to increase productivity while enjoying various forms of entertainment. Enjoy unparalleled satisfaction provided by infotainment of Hyundai's state-of-the-art information technology!



// **HL970A with advanced technology ensures our safety on a construction site.** //



The A Series in wheel loaders are products of HCE's spirit of initiative, creativity, and strong drive. HCE engineers, who are the best in the industry, have worked tirelessly to offer a zero-defect product. The new A Series in wheel loaders reflects customers' needs in the field gleaned by thorough monitoring.

Emergency Stop

In an emergency, operating the Emergency Stop switch located at the bottom of the seat will shut down the engine starting.



Seat Belt Warning Alarm

Seat belt warning alarm allows the operator to work in a safer environment.

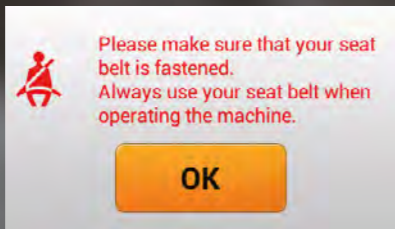

Radar Option

The Radar system can detect rear obstacles without blind spots and no distinction between day and night. Also, the warning level of the nearest obstacle is always displayed on the secondary monitor.

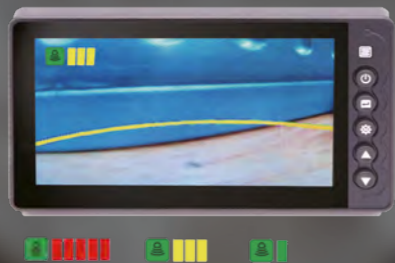

AAVM+(Advanced Around View Monitoring) NEW Option

This is a system that is combined AVM (Around View Monitoring) with IMOD (Intelligent Moving Object Detection) and detects people around the machine and analyzes the images, which displays a warning sign on a monitor when detecting the danger. So operators can watch the surroundings in a variety of angles through the monitor and prevent the safety accident in advance.

AAVM+ NEW Option



It offers *reverse guidelines* and a feature that alerts you only to objects detected in the reversing path.

See-Through Bucket NEW Option



It enhances safety by improving monitor visibility in areas obscured by the bucket.

AVM



IMOD



THE ULTIMATE SAFE ENVIRONMENT

With the top priority on satisfaction of operators in terms of silence, safety and maintainability, Hyundai wheel loaders provide operators with comfortable cabin space by low-vibration, low-noise, and superior safety design. They also offer greater satisfaction by extending the replacement cycle of supplies and minimizing maintenance time and cost.



*Photo may include optional equipment.



SERVICEABILITY AND TELEMATICS

IoT, ICT, AI-based digital technologies is creating smart construction sites. Maximizes connectivity, productivity, and safety for your successful businesses.



Hi MATE

Option

IT'S CONVENIENT, EASY AND VALUABLE

Hi MATE Hyundai's newly developed remote management system, utilizes GPS-satellite technology to provide customers with the highest level of service and product support available. Hi MATE enables users to remotely evaluate machine performance, access diagnostic information, and verify machine locations at the touch of a button.

WHAT IS BENEFITS



Increase Productivity

It helps you operate machines in efficient. You can check the difference between total engine hours and actual working hours. See how productive your machines are and plan any required cost saving solutions. Hi MATE offers working information such as working / idling hours, fuel consumption and rate.



Convenient and Easy Monitoring

There is nothing much to do to monitor your machines. Just log on to the Hi MATE website or mobile application. Hi MATE allows you to watch your machines whenever and wherever you are.



Security

Protect your machines from theft or unauthorized usage with Hi MATE. If the machine moves out of the Geofence boundary, you will get alerts.

Unnecessary Regular DPF Cleaning Interval

Regular ash cleaning for DPF is not necessary, only needed as indicated by fault-indicator lamp.

ECD(Engine Connected Diagnostics)

It supports service technician with remote diagnostics report and ensure it arrive on site with proper tools after preparing in advance.

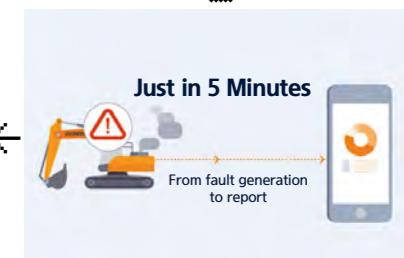
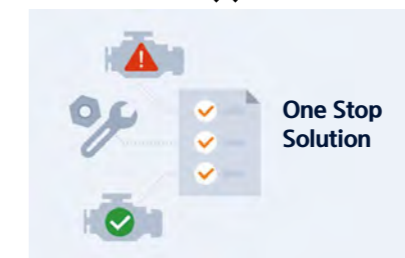

Fully Openable Engine Hood

The HL970A has improved accessibility to the sealed engine room with retractable hood to allow easy cleaning and maintenance. The engine room was designed to prevent possibility of fire due to inflow of foreign materials. The fully retractable engine hood in the electric actuator opening mode also enhances maintainability of the engine room and cooling room.



Easy Filter Replacement

With easy filter replacement, machine can be managed more easily.



Wide Core & Fin Radiator

Wide core & fin radiator reduces clogging.



Longer Lasting Filter

The service interval of engine oil, engine oil filter and fuel filters has been increased from 500 hours to 1,000 hours.



SPECIFICATIONS

ENGINE

Maker / Model	CUMMINS / L9
Type	6 cylinder, water cooled, 4-cycle, turbocharged, charge air cooled, direct injection, electronic controlled diesel engine
Gross Power (SAE J1995)	325 HP (242 kW) at 2,100 rpm
Net Power (SAE J1349)	322 HP (240 kW) at 2,100 rpm
Max. Power	330 HP (246 kW) at 2,000 rpm
Peak Gross Torque (SAE J1995)	1636 N·m (1,207 lb.ft) at 1,100 rpm
Displacement	8.9 l (543 cu in)

HYDRAULIC SYSTEM

Type	Load sensing hydraulic system
Pump	Variable displacement piston pump 376 lpm
Control Valve	2 Spool (Bucket, Boom) 3 Spool (Bucket, Boom, Aux)
System Pressure	280 bar (4,061 psi)
Lift Circuit	The valve has four functions: Raise / Hold / Lower / Float Can adjust automatic kickout from horizontal to full lift.
Tilt Circuit	The valve has three functions: Tilt back / Hold / Dump Can adjust automatic bucket positioner to desired load angle.
Cylinder	Type: double acting No. of cylinders-bore × stroke Lift 2-165 × 780 mm (2-6.5" × 2' 6.7") HL970A Tilt 1-180 × 565 mm (1-7.1" × 1' 10.2") HL970A XT Tilt 1-180 × 570 mm (1-7.1" × 1' 10.4")
Cycle Time	Raise : 6.0 Sec. / Dump : 1.5 Sec. Lower : 4.3 Sec. / Total : 11.8 Sec.

* Hyundai Bio Hydraulic Oil (HBHO) available

TRANSMISSION

Torque Converter Type	3-Elements, Single-stage, Single phase
Tire	26.5R25 L3, ★★, L3

TRANSMISSION

Travel Speed	4 speed T/M		5 Speed T/M with lock up clutch	
	km/h (mph)		km/h (mph)	
Forward	1st	7.4 (4.6)	7.4 (4.6)	
	2nd	12.5 (7.8)	12.6 (7.8)	
	3rd	27.8 (17.3)	20.1 (12.5)	
	4th	40.0 (24.9)	28.7 (17.8)	
	5th	-	40.0 (24.9)	
Reverse	1st	7.4 (4.6)	7.4 (4.6)	
	2nd	12.5 (7.8)	12.6 (7.8)	
	3rd	27.8 (17.3)	28.7 (17.8)	

AXLES

Drive System	Four-wheel drive system
Mount	Fixed
Rear Axle Oscillation	Oscillating ± 11 degrees
Hub Reduction	Planetary reduction at wheel end
Differential	Conventional
Reduction Ratio	24.666

TIRES

Type	Tubeless, loader design tires
Standard	26.5R25 L3, ★★, L3
Options Include	26.5-25, 20PR L5 26.5R25 XHA, ★, XHA 26.5-25 20PR L3

OVERVIEW

Description	HL970A	HL970A XT
Operating Weight	24,700 kg (54,455 lb)	25,000 kg (55,120 lb)
Bucket Capacity	Heaped 4.20 m³ (5.50 yd³) Struck 3.60 m³ (4.70 yd³)	4.20 m³ (5.50 yd³) 3.60 m³ (4.70 yd³)
Breakout Force-Bucket	21,715 kg (47,875 lb)	21,775 kg (48,010 lb)
Tipping Load	Straight 19,550 kg (43,100 lb)	16,250 kg (35,830 lb)
	Full Turn 16,890 kg (37,240 lb)	13,950 kg (30,755 lb)

BRAKES

Service Brakes	Hydraulically actuated, wet disc brakes actuate all 4 wheels independent axle-by-axle system. Self adjusting & wheel speed brake.
Parking Brake	Spring-applied, hydraulically released brake
Emergency Brake	When brake oil pressure drops, indicator light alerts operator and parking brake automatically applies.

STEERING SYSTEM

Type	Load sensing hydrostatic articulated steering
Pump	Variable displacement piston pump, 242 lpm
System Pressure	210 bar (3,046 psi)
Cylinder	Double acting 2-95 × 468 mm (2-3.7" × 1' 6.4")
Steering Angle	40° to both right and left angle, respectively
Features	Center-point frame articulation. Tilt and telescopic steering column.

SERVICE REFILL CAPACITIES

Fuel Tank	365 liters (96.4 US gal)
Def Tank	44.5 liters (11.8 US gal)
Cooling System	47 liters (12.4 US gal)
Crankcase	22.7 liters (6.0 US gal)
Transmission	53 liters (14 US gal)
Front Axle	42 liters (11.1 US gal)
Rear Axle	42 liters (11.1 US gal)
Hydraulic Tank	152 liters (40.2 US gal)
Hydraulic System (Including Tank)	276 liters (72.9 US gal)

CABIN

ROPS / FOPS meet ISO 3471 and ISO 3449

SOUND

Guaranteed noise level presented below can be differed depending on a range of factors such as operating condition, speed of a cooling fan, types of engine and so forth. Hearing protection shall be necessary if an operator is working in the improperly maintained cabin or exposed to a noisy environment by leaving doors and/or windows open.

Operator sound pressure level (ISO 6396:2008)	70 dB(A)
Exterior sound power level (ISO 6395:2008)	107 dB(A)

* Distance of 15 m (49.2 ft), moving forward in second gear ratio.

DIMENSIONS & SPECIFICATIONS

DIMENSIONS

All dimensions are approximate.

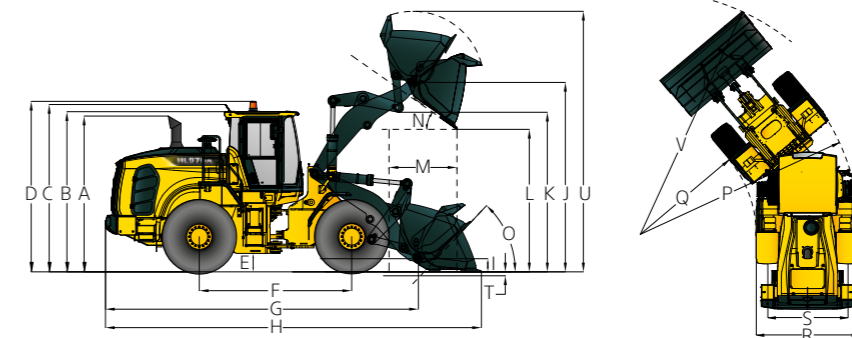

Unit : mm (ft · in)

Description	HL970A	HL970A XT
A Height to Top of Exhaust Pipe	3,570 (11' 9")	3,570 (11' 9")
B Height to Top of Cabin	3,590 (11' 9")	3,590 (11' 9")
C Height to Top of Product Link Antenna	3,665 (12' 0")	3,665 (12' 0")
D Height to Top of Warning Beacon	3,720 (12' 2")	3,720 (12' 2")
E Ground Clearance	480 (1' 7")	480 (1' 7")
F Wheelbase	3,500 (11' 6")	3,500 (11' 6")
G Overall Length (Without Bucket)	7,395 (24' 3")	7,935 (26' 0")
H Shipping Length (With Bucket Level on Ground)	8,740 (28' 8")	9,280 (30' 5")
I Hinge Pin Height at Carry Position	500 (1' 8")	615 (2' 0")
J Hinge Pin Height at Maximum Lift	4,325 (14' 2")	4,815 (15' 10")

Description	HL970A	HL970A XT
K Lift Arm Clearance at Maximum Lift	3,605 (11' 10")	4,095 (13' 5")
L Dump Clearance at Maximum Lift and 45° Discharge	3,080 (10' 1")	3,570 (11' 9")
M Reach at Maximum Lift and 45° Discharge	1,270 (4' 2")	1,255 (4' 1")
N Dump Angle at Maximum Lift and Dump (on Stops)	50	50
O Roll Back Angle	Ground 43 Carry 47	43 49
P Clearance Circle (Diameter) to Outside of Tires	12,885 (42' 3")	12,885 (42' 3")
Q Clearance Circle (Diameter) to Inside of Tires	6,800 (22' 4")	6,800 (22' 4")
R Width Over Tires (Unloaded)	2,980 (9' 9")	2,980 (9' 9")
S Tread Width	2,300 (7' 7")	2,300 (7' 7")

OPERATING SPECIFICATIONS WITH BUCKETS

Linkage Bucket Type	General Purpose Pin On			General Purpose - Hook On		High Lift Linkage Change
	Bolt - On Cutting Edges	Bolt-On Cutting Edges	Bolt-On Cutting Edges	Bolt-On Cutting Edges	Bolt-On Cutting Edges	
Capacity - Rated	4.20 m³ (5.50 yd³)	5.20 m³ (6.80 yd³)	4.50 m³ (5.90 yd³)	4.20 m³ (5.50 yd³)	-	
Capacity - Rated at 110% Fill Factor	4.62 m³ (6.00 yd³)	5.72 m³ (7.50 yd³)	5.90 m³ (4.95 yd³)	4.62 m³ (6.00 yd³)	-	
Width	3,100 mm (10' 2" ft/in)	3,250 mm (10' 8" ft/in)	3,100 mm (10' 2" ft/in)	3,100 mm (10' 2" ft/in)	-	
Dump Clearance at Maximum Lift & 45° Discharge	3,080 mm (10' 1" ft/in)	2,975 mm (9' 9" ft/in)	3,040 mm (9' 12" ft/in)	2,865 mm (9' 5" ft/in)	+490 mm (+1' 7" ft/in)	
Reach at Maximum Lift & 45° Discharge	1,270 mm (4' 2" ft/in)	1,375 mm (4' 6" ft/in)	1,310 mm (4' 4" ft/in)	1,485 mm (4' 10" ft/in)	-15 mm (-0.6" ft/in)	
Digging Depth	100 mm (0' 4" ft/in)	100 mm (0' 4" ft/in)	100 mm (0' 4" ft/in)	100 mm (0' 4" ft/in)	+15 mm (+0.6" ft/in)	
T Shipping Length (with Bucket)	8,740 mm (28' 8" ft/in)	8,890 mm (29' 2" ft/in)	8,800 mm (28' 10" ft/in)	9,045 mm (29' 8" ft/in)	+540 mm (+1' 9" ft/in)	
U Overall Height with Bucket at Maximum Lift	5,970 mm (19' 7" ft/in)	6,120 mm (20' 1" ft/in)	6,030 mm (19' 9" ft/in)	6,185 mm (20' 4" ft/in)	+490 mm (+1' 7" ft/in)	
V Loader Clearance Circle with Bucket at Carry Position	14,310 mm (46' 11" ft/in)	14,540 mm (47' 8" ft/in)	14,350 mm (47' 1" ft/in)	14,500 mm (47' 7" ft/in)	+400 mm (+1' 4" ft/in)	
Static Tipping Load. Straight (No Tire Deflection)	19,550 kg (43,100 lb)	17,900 kg (39,465 lb)	18,300 kg (40,345 lb)	16,500 kg (36,380 lb)	-2,100 kg (-4,625 lb)	
Static Tipping Load. Articulated (No Tire Deflection)	16,890 kg (37,240 lb)	15,500 kg (34,175 lb)	15,800 kg (34,835 lb)	14,250 kg (31,420 lb)	-1,900 kg (-4,185 lb)	
Breakout Force	21,715 kg (47,875 lb)	19,540 kg (43,080 lb)	20,785 kg (45,825 lb)	17,700 kg (39,025 lb)	+60 kg (+135 lb)	
Operating Weight*	24,700 kg (54,455 lb)	24,475 kg (53,960 lb)	24,255 kg (53,475 lb)	24,840 kg (54,765 lb)	+800 kg (+1,765 lb)	

BUCKET SELECTION CHART

DENSITY OF OPERATING MATERIALS		
Loose Material	Material Density [ton / m ³]	
Earth / Clay	1.5 ~ 1.7	
Sand and Gravel	1.5 ~ 1.7	
Aggregate	25 ~ 76 mm (1" to 3 in)	1.6 ~ 1.7
	19mm (3 in) and Larger	1.8

HL970A BUCKET SELECTION CHART

Standard Lift Arm - General Purpose Bucket																	
Type	m ³ (yd ³)	Material Density [ton / m ³]															
		0.8	0.9	1.0	1.1	1.2	1.3	1.4	1.5	1.6	1.7	1.8	1.9	2.0	2.1	2.2	2.3
Cutting Edge	4.2 (5.49)	4.8 m ³ (6.28 yd ³)										4.0 m ³ (5.23 yd ³)					
Cutting Edge	5.2 (6.8)	6.0 m ³ (7.85 yd ³)					4.9 m ³ (6.41 yd ³)										
Cutting Edge	4.5 (5.89)	5.2 m ³ (6.8 yd ³)						4.3 m ³ (5.62 yd ³)									
Cutting Edge Q/C	4.2 (5.49)	4.8 m ³ (6.28 yd ³)						4.0 m ³ (5.23 yd ³)									

High Lift Arm (XT) - General Purpose																	
Type	m ³ (yd ³)	Material Density [ton / m ³]															
		0.8	0.9	1.0	1.1	1.2	1.3	1.4	1.5	1.6	1.7	1.8	1.9	2.0	2.1	2.2	2.3
Cutting Edge	4.2 (5.49)	4.8 m ³ (6.28 yd ³)										4.0 m ³ (5.23 yd ³)					
Cutting Edge	5.2 (6.8)	6.0 m ³ (7.85 yd ³)					4.9 m ³ (6.41 yd ³)										
Cutting Edge	4.5 (5.89)	5.2 m ³ (6.8 yd ³)						4.3 m ³ (5.62 yd ³)									
Cutting Edge Q/C	4.2 (5.49)	4.8 m ³ (6.28 yd ³)						4.0 m ³ (5.23 yd ³)									

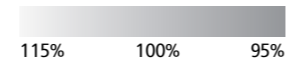

CHANGE IN OPERATING SPECIFICATIONS - TIRES

Tires		26.5-25, 20PR L5	26.5R25, ★, XHA	26.5-25 20PR L3
Operating Weight (kg)	kg	+520	-230	-340
	lb	+1,150	-505	-745
Static Tipping Load, Straight (No Tire Deflection)	kg	+350	-160	-235
	lb	+775	-350	-515
Static Tipping Load, Articulated (No Tire Deflection)	kg	+300	-135	-200
	lb	+665	-295	-440
Vertical Height Changes	mm	+58	-9	+20
	ft/in	+0.2"	-0.0"	+0.1"
R. Width Over Tires (Unloaded)	mm	+13	-3	+11
	ft/in	+0.1"	-0.0"	+0.0"
P. Clearance Circle (Diameter) to Outside of Tires	mm	+13	-3	+11
	ft/in	+0.1"	-0.0"	+0.0"
Q. Clearance Circle (Diameter) to Inside of Tires	mm	-13	+3	-11
	ft/in	-0.1"	+0.0"	-0.0"

* Dimension changes compared to 26.5R25, ★★, L3 radial tires.

STANDARD / OPTION

CAB & INTERIOR	STD	CAB & INTERIOR	STD
ALARMS, AUDIBLE AND VISUAL		IGNITION	
Emergency Warning Lamp	●	Key	●
Engine Coolant Temperature	●	Button	
Transmission Oil Temperature	●	MEMBRANE SWITCHES IN MONITOR	
Hydraulic Oil Temperature	●	Main Light	●
Fuel Level	●	Work Light	●
Transmission Error	●	Auto Grease	
Air Filter Clogging	●	Quick Coupler	
Engine Oil Pressure	●	Ride Control	
Battery Voltage	●	Weighing System	●
Brake Oil Pressure	●	Beacon Light	
Engine Stop	●	Rear Wiper	●
Engine Coolant Level	●	Mirror Heat	●
BATTERIES		Auto Position	●
925 CCA, 12 V, 2 pcs	●	Fine Modulation	●
GAUGES		Rear View Camera	●
Engine Coolant Temperature	●	CABIN (SOUND SUPPRESSED)	
Fuel Level	●	ROPS/ FOPS Cabin	●
Transmission Oil Temperature	●	Coat Hook	●
Speedometer	●	Rear View Mirrors (1 Inside)	●
INDICATOR LIGHTS		Rear View Mirrors (2 Outside, Heated)	●
Parking Brake	●	Steering Column, Tilt and Telescopic	●
High Beam	●	Steering Wheel with Knob	●
Joystick Steering		Roller Type Sunshade (Front Window)	●
FNR		Roller Type Sunshade (Rear Window)	
Differential Lock		Tinted Safety Glass	●
Pilot Cut Off	●	One Door Cabin	●
Turning Light	●	Magazine Pocket	●
Seat Belt ON/OFF	●	Radio / USB Player	●
Engine Auto Stop	●	Rubber Floor Mat	●
Clutch Cut Off	●	Wrist rest & Armrest	●
Ride Control		24 V to 12 V DC Converter (20 A)	●
LCD DISPLAY		Cigar Lighter & Ashtray	
DEF Level	●	DOOR	
DEF low Level	●	Door and Cabin Locks, One Key	●
Transmission Gear Range	●	Doors, Service Access (Locking)	
Clock and Fault Code	●	Doors, Service Access (Remote Control)	
Job Time and Distance	●	AUTOMATIC CLIMATE CONTROL	
Operating Hour Counter	●	Air Conditioner and Heater	●
Engine rpm	●	Defroster	●
Horn, Electric	●	Intermittent Wiper and Washer, Front and Rear	●
LIGHTING SYSTEM		SEAT	
LED Dome Light	●	2" Retractable Seat Belt & Adjustable Mechanical Suspension (HEated)	●
2 Stop and Tail Lights	●	2" Retractable Seat Belt & Adjustable Air Suspension (HEated)	
4 Turn Signals	●	3" Retractable Seat Belt & Adjustable Air Suspension (HEated)	
Brake Lights (Counterweight)	●	PERSONAL STORAGE SPACE	
2 LED Rear Combi Lamp		Console Box	●
2 Head Lights on Front Tower	●	Holder, Can and Cup	●
2 LED Head Light		PEDALS	
2 Working Lights on Front Roof	●	One Accelerator Pedal	●
4 Working Lights on Front Roof,		One Brake Pedal	●
2 Working Lights on Rear Roof		Dual-Brake Pedal	
4 Working Lights (LED) on Front Roof,		Accel Pedal Without ECO Switch	●
2 Working Lights (LED) on Rear Roof		Accel Pedal With ECO Switch	
2 Working Lights on Grill	●	SWITCHES	
2 Working Lights (LED) on Grill		Hazard	●
SWITCHES		DPF	●
Hazard	●	Engine Hood Open	●
DPF	●	Parking	●
Engine Hood Open	●	Battery Master Switch	●
Parking	●	FNR Shifter	●
Battery Master Switch	●	Differential Lock Foot Switch	
FNR Shifter	●	Emergency Steering	
Differential Lock Foot Switch		Pilot Cut Off	●
Emergency Steering		Air Compressor	
Pilot Cut Off	●		
Air Compressor			

STANDARD / OPTION

ENGINE	STD
Alternator, 95A	●
Antifreeze	●
Fuel Warmer	●
Fan Guard	●
Rain Cap, Engine Air Intake	●
Coolant Level Sight Gauge	●
Radiator	
Centrifugal Air Precleaner	●
ENGINE, CUMMINS, L9	
EU Stage V / EPA TIER 4 FINAL	●
Engine Fuel Priming Pump	●
Fuel / Water Separator	●
Engine Oil Level Dipstick Gauge	●
CLEAN EMISSION MODULE	
DOC, DPF and SCR	●
POWER TRAIN	
Torque Converter	●
Travel speed limiter (20-40 km/h)	●
Axle Cooling sSystem	
TRANSMISSION	
Transmission F4 / R3, Computer Controlled, Electronic Soft Shift, Auto-Shift And Kick-Down Features Included	●
Transmission F5 / R3 with lock-up clutch & Thermostat	
Transmission Oil Sight Level	●
BRAKE	
Service Brake (Enclosed Wet-Disc)	●
Parking Brake	●
FRONT AXLE	
Open Differential	
Limited Slip Differential	
Hydraulic Lock Differential	●
REAR AXLE	
Open Differential	
Limited Slip Differential	●
TIRES	
26.5R25, ★★, L3	●
26.5-25, 20PR L5	
26.5R25, ★, XHA	
26.5R25, ★★, L4	
HYDRAULIC SYSTEM	
Boom Kickout, automatic	●
Bucket Positioner, Automatic	●
Diagnostic Pressure Taps	●
Hydraulic Oil Cooler	●
EH Control (Joystick)	●
EH Control (Fingertip)	
EH Joystick Steering	
Ride Control System	
Secondary Steering System	
Extra Piping-for Auxiliary Function	
Quick Coupler Piping	
Auto Greasing	
Hyundai Bio Hydraulic Oil (HBHO)	

OTHER	
Articulation Locking Bar	●
Lift and tie-Down Hooks	●
Loader Linkage, Sealed	●
Z-bar Design	●
Vandalism Protection Caplocks	●
Air Compressor	
Long Boom	
Tool Kit	
COUNTERWEIGHT	
Counterweight	●
Counterweight - Heavy Weight	
Drawbar with Pin	●
ERGONOMICALLY LOCATED AND SLIP RESISTANT, LEFT & RIGHT	
Handrails	●
Ladders	●
Platforms	●
Steps	●
BUCKET	
4.2m³ Bolt-on Cutting Edge Type Bucket	●
4.0m³ Bucket 1-Bolt-on Tooth Type	
4.0m³ Bucket 2-Bolt-on Tooth Type	
4.2m³ Bucket 2-Bolt-on Tooth & Segment Edge Type	
5.2m³ Bolt-on Cutting Edge Type Bucket	
5.0m³ Bucket 1-Bolt-on Tooth Type	
5.0m³ Bucket 2-Bolt-on Tooth Type	
4.5m³ Bolt-on Cutting Edge Type Bucket	
3.7m³ Bucket Spade Nose Rock Type	
4.2m³ Bolt-on Cutting Edge ISO Q/C Bucket	
GUARDS	
Fenders (Front / Rear)	●
Crankcase	
Transmission	
Cabin Glass (Front / Rear)	
Mud Guard	
SAFETY	
Emergency Stop	●
Fire Extinguisher	
Boom Safety Bar	
Emergency Steering	
OBJECT DETECTION	
AAVM+(Advanced Around View Monitoring)	
See-through Bucket	
Secondary Monitor	
Radar	
TELEMETICS	
ECD (Engine connected Diagnostics)	●
Hi MATE	●

* Standard and optional equipment may vary. Contact your Hyundai dealer for more information. The machine may vary according to International standards.
 * The photos may include attachments and optional equipment that are not available in your area.
 * Materials and specifications are subject to change without advance notice.
 * All imperial measurements rounded off to the nearest pound or inch.

MEMO