

HA30 / HA45

Articulated Dump Truck

TIER2

TIER4F

* Photo may include optional equipment.



Head Office(Sales Office)
14F, GLOBAL R&D CENTER, 477 BUNDANG SUSEO-RO, BUNDANG-GU, SEONGNAM-SI, GYEONGGI-DO, 13553, KOREA

PLEASE CONTACT

Net Weight
23,200 to 30,100 kg

Max Power
276 kW (370 HP) to 368 kW (493 HP)

Body Volume
17.8 to 26.0 m³

Max Payload
28,000 to 41,000 kg

TAKE THE TOUR!

HA30 / HA45

PRODUCTIVITY & EFFICIENCY

- Powerful TIER2 / TIER4 engines
- Permanent 6-wheel drive
- Rear tandem axles
- Front-mounted turning ring
- Equal power and weight distribution
- Limited slip differentials
- Independent front wheel suspension
- Sloping chassis design
- Adjustable hydraulic retarder
- Heated body **Option**
- Compact rear frame and body

COMFORT

- Spacious ROPS/FOPS cab
- Climate control & air suspension seat
- Precise steering
- Low noise levels
- Convenient 7" LCD colour display panel
- Electronically managed body hoist lever
- Suspended mounted cab
- Extra storage space
- Electric mirrors **Option**
- 1 key to unlock and start engine

SERVICEABILITY

- Simplified cab tilt gives easy service access
- Ground level access to key service areas
- Oil-cooled wet disc brakes with up to 15,000 hour life
- Steel bearings lasting at least 12,000 hours
- Auto grease system as standard
- One rear differential and simpler driveline
- Equal weight distribution for less tyre wear
- Multifunctional service and maintenance display

SAFETY

- Easy front cab access from the front
- Fenders and hand rails
- Superior machine stability
- Sloping hood design for greater visibility
- Hydraulic transmission retarder
- Hydraulically activated mechanical parking brake
- Short front frame to handle obstacles better
- Automatic over centre of gravity feature





PRODUCTIVITY & PERFORMANCE THE ULTIMATE ADT

Permanent 6-wheel drive, rear tandem axles and front-mounted turning ring, provide equal power and weight distribution for optimal operating performance. A sloping rear frame guides loads to the front, increasing traction and providing a lower centre of gravity for greater stability and fast and easy tipping of the body for increased productivity.

Front and rear differentials are limited slip while longitudinal differential can be manually locked.



TRAVEL SPEED

Up to 55 km/h travel speed and Tip-tronic gear shift provide smoother operation whilst maintaining maximum momentum. The truck can also be run in both automatic and manual gears.



LOAD RETENTION

Adjustable hydraulic retarder keeps the machine's speed constant on downhills, without the support of service brakes. A sloping chassis keeps more fluid or wet materials including gravel inside the tipping body. An optional rear tailgate increases body capacity and improves load retention for greater working efficiency.

UNLOADING

The optional heated body prevents frozen material sticking to it, enabling quicker and easier unloading.



Optimum operating performance

Manouverable

The turning ring is located in front of the articulation point, ensuring equal weight distribution to the front wheels in all operating situations, including maximum turning. This enables you to use the limited slip differentials with only 45% locking value, ensuring drive to both front wheels without completely locking.

Our rear frame and body design, combined with the front-mounted differential makes for a compact ADT, resulting in a small turning radius and outstanding stability.

More contact points with the ground make the machine more stable while turning. This offers a safer and more comfortable ride.



Tough terrain

The tandem rear axle showcases a massive 40° rotation to give unbeatable performance, traction and ground engagement over rough ground. This helps increase productivity and fuel efficiency.

Independent front wheel suspension allows free movement up front so that obstacles don't affect the back suspension or axles.





RELIABILITY AND EFFICIENCY

Proven and reliable engines provide all the power you need, with excellent torque and low fuel consumption whilst meeting TIER2 / TIER 4F regulation requirements. Other features combined with world-class components further increase efficiency and decrease cost of ownership.



Powerful and cost effective

Proven TIER 2/ TIER 4F engines deliver 276 kW (370 HP) to the HA30 and 368 kW (493 HP) to the HA45, providing high torque at low rpm with low fuel consumption.

Intelligent design for improved economy

Suspension

Our self-leveling, hydro-gas front suspension system provides outstanding performance in rough terrain, especially when the machine is empty. It can also be adjusted to match changing working conditions.

Differential and driveline

Our design has one rear differential and a simple driveline, resulting in less moving parts for easier and lower cost maintenance.



Payload

Our standard real-life payload and load count meter provide both operator and owner with an immediate productivity report. External indication lights on the HA45 (optional) help load the body more efficiently.

Compact

With a less than 3-meter width, the HA30 can be easily moved from one site to another. And thanks to the compact design of both machines, a shorter low loader can be used.





COMFORTABLE AND ERGONOMIC

A spacious cab and easy-to-use controls are essential for optimum operator comfort and productivity. Hyundai ADTs have all that and more, providing the perfect office environment for long hours working in some of the toughest conditions.



Our spacious ROPS/FOPS cab is equipped with climate control and a high-quality operator seat with air suspension and armrest, for greater operator comfort.

Comfort for efficient operation

LCD display

A convenient 7" LCD colour display panel shows all the important control and safety information including that from a rear-view camera, real-life payloadmeter with external light indication on the HA45 and body tip boost button.



Convenience

A radio as standard supports all modern features including MP3, DAB and Bluetooth.

There are plenty of storage spaces and extra room designed to fit a cool or hot box. An additional 12V power supply is also provided.

Just 1 key locks and unlocks all the doors and also starts the engine.

Electrically heated and adjustable mirrors are optional available.



Hoist lever

An electronically managed body hoist lever is easy to operate with fingertip control. It incorporates a higher body up speed and an automatic body down feature, with soft touch, to keep you safe at all times.



Seat

High-comfort air-suspension seat because a highly comfortable seat means a lot to every operator, we provide an air-suspension seat with armrest as standard.

Focus

Precise steering, good visibility and low noise levels, provide additional comfort and quiet.

The cab is mounted on a special rubber suspension to reduce vibration and conduction of noise into the cab.





FULLY EQUIPPED FOR YOUR SAFETY

Safety is paramount on any worksite and both Hyundai ADTs come with many important features that provide all operators with greater confidence and peace of mind. Easier front access to the cab, superb visibility and overall machine stability come as standard.

Easy cab access from the front, fenders and hand rails, plus superior machine stability, all provide greater safety.



Dumping

Automatic over centre of gravity feature slows down the body hoist system, if it senses material stuck to the body when dumping.



Parking brake

Standard hydraulic transmission retarder and hydraulically activated mechanical parking brake add peace of mind.

Short front frame

The short front frame is designed to handle obstacles better and drive inertia along with the turning direction. This greatly improves safety when turning in tight corners.

Visibility

A sloping hood design provides the operator with an excellent view.





SIMPLE SERVICING INCREASES UPTIME

Hyundai ADTs have been designed with longer lasting parts and easier servicing and maintenance, to save time and reduce costs. After all, less downtime means more time working and ultimately more time earning money.



Convenient access

Easy ground level access to key service areas like diesel and Adblue® filling points and filters.



Multifunctional service and maintenance display makes it easy to check transmission oil level, plus hydraulic and electronic components.



Less wear and tear

Equal weight distribution ensures the same load on every tyre and so, less wear but greater traction. Oil-cooled wet discbrakes with a lifetime of up to 15,000 hours. New steel bearings last at least 12,000 hours.

One rear differential and a far simpler driveline means less moving parts, for easier and more economical maintenance.

A simplified cab tilt gives easy service access to the machine.



TELEMATICS TECHNOLOGY FOR SMART CONSTRUCTION

IoT, ICT, AI-based digital technologies is creating smart construction sites.
Maximizes connectivity, productivity, and safety for your successful businesses.



HiMATE

It's Convenient, Easy and Valuable

Hi-mate Hyundai's newly developed remote management system, utilizes GPS-satellite technology to provide customers with the highest level of service and product support available. Hi-mate enables users to remotely evaluate machine performance, access diagnostic information, and verify machine locations at the touch of a button.

What is benefits



INCREASE PRODUCTIVITY

It helps you operate machines in efficient. You can check the difference between total engine hours and actual working hours. See how productive your machines are and plan any required cost saving solutions. Hi-mate offers working information such as working / idling hours, fuel consumption and rate.



CONVENIENT AND EASY MONITORING

There is nothing much to do to monitor your machines. Just log on to the Hi-mate website or mobile application. Hi-mate allows you to watch your machines whenever and wherever you are.



SECURITY

Protect your machines from theft or unauthorized usage with Hi-mate. If the machine moves out of the Geo-fence boundary, you will get alerts.



SPECIFICATIONS

ENGINE	HA30	HA45
Maker / Model	Scania DC 9	Scania DC 13
Type	Water-cooled, diesel engine with turbo charger and air-to-air intercooler	
Aftertreatment System	EGR / SCR	
Power Rating ISO 3046 / ISO 14396 @ 2100 rpm	Tier2 358hp(267kW)/ Tier4F 370hp(276kW)	Tier2 493hp(368kW)/ Tier4F 493hp(368kW)
No. of Cylinders	5 (in line)	6 (in line)
Gross Torque	1873 Nm@1,300 rpm	2373 Nm@1,300 rpm
Displacement	9.3 litres	12.7 litres
Bore Diameter X Stroke	130 X 140 mm	130 X 160 mm
Air Filter	2-stage (main + safety), dry type	
Emissions	Complies with TIER2/TIER4 of emission regulation	

ELECTRICAL SYSTEM	HA30	HA45
Voltage	24 V	
Battery	2 x 12 V	
Battery Capacity	2 x 105 Ah	
Starter Motor	6 kW(8HP)	
Alternator	24 V / 100 A	

DRIVETRAIN	HA30	HA45
Torque Converter	Lock up function in all gears	
Transmission	Electronically-controlled automatic transmission with retarder, Full-time 6X6 drive with two transverse differentials and one longitudinal Inter-axle longitudinal, Torque-proportioning differential, integrated into the ZF transmission	
Front Axle Transverse Differential	Limited-slip diff lock with 45% locking ratio mounted directly at transmission	
Rear Axle Transverse Differential	Limited-slip diff lock with 45% locking ratio	
Torque Distribution (100% Lockable)	1/3 to the front axle, 2/3 to the rear axle	

STEERING SYSTEM	HA30	HA45
Cylinder	Two double-acting	
Standard	The steering is approved according to ISO 5010	
Max. Steering Angle	15°	
Emergency Steering	Ground-driven emergency steering pump	

TRANSMISSION	HA30	HA45
Maker / Model	ZF 8 EP320	ZF 8 EP420
Travel Speed - Forward		
1st	6 km/h	6 km/h
2nd	8 km/h	9 km/h
3rd	11 km/h	12 km/h
4th	16 km/h	17 km/h
5th	23 km/h	24 km/h
6th	32 km/h	34 km/h
7th	45 km/h	48 km/h
8th	55 km/h	55 km/h
Travel Speed - Reverse		
1st	6 km/h	6 km/h
2nd	8 km/h	9 km/h
3rd	11 km/h	12 km/h
4th	16 km/h	17 km/h
Front Hubs	Kessler	
Rear Axle + Hubs	Kessler	
Rear Tandem	Hyundai (in house)	

BRAKES	HA30	HA45
Service Brakes	Dual circuit braking system acting on all six wheels, all hydraulic-operated brakes with enclosed oil-cooled wet multiple discs on four hubs (braking force distributed to two hubs by tandem gear wheels).	
Parking Brake	Spring actuated mounted on driveline shaft	
Max. Gradient, Parking Brake	15°	
Retarder	Automatic transmission retarder standard	
Brake System	Complies with ISO3450	

CABIN
ROPS / FOPS cabin meet ISO 3471 and ISO 3449
Hand and arm vibrations are less than 2.5 ms ⁻² (ISO 5349-2)
Whole body vibration is less than 0.5 ms ⁻² (ISO 2631-1)

AIR CONDITIONING SYSTEM
The air conditioning system contains Fluorinated greenhouse gas refrigerant R134a (Global Warming Potential = 1430). The system contains 2.0 kg of refrigerant representing a CO2 equivalent of 2.86 metric tonnes.

SPECIFICATIONS

HYDRAULIC SYSTEM	HA30	HA45
Type	1 variable displacement piston pump for steering, tipping, cooling fan, brakes & auxiliaries	
Maximum Pump Output	294 l/min @ 2,100 rpm	
Filtration	return flow filter	
Main Safety Valve Pressure Tipping	280 bar	
Main Safety Valve Pressure Steering Circuit	210 bar	
Tilt Cylinders	Single stage, double-acting	
Tipping Time Raise	12 secs	10 secs
Tipping Time Lower	10 secs	10 secs

BODY	HA30	HA45
Body Volume (Without Tailgate)	16.8 m ³	24.4 m ³
Material	Hardened abrasion-resistant steel plates (400 HB)	
Body Tipping Angle	70°	
Level Capacity (with / without tailgate)	14.2 m ³ / 13.6 m ³	20.4 m ³ / 19.6 m ³
Heaped capacity (with / without tailgate)	17.8 m ³ / 16.8 m ³	26.0 m ³ / 24.4 m ³

TYRES	HA30	HA45
Standard	23.5R25 **	29.5R25 **
Optional	750/65R25	875/75R29

WEIGHTS	HA30	HA45	
Empty	Front Axle	12500 kg	14500 kg
	Rear Axle	10600 kg	16000 kg
Net Weight	23200 kg	30100 kg	
Max. Admissible Axle Load	Front Axle	16700 kg	22500 kg
	Rear Axle	37000 kg	55000 kg
Max. Admissible Total Weight	51200 kg	71100 kg	
Payload	28 metric ton / 31 short ton	41 metric ton / 45 short ton	

POWER TO WEIGHT RATIO	HA30	HA45
Empty	11.9 kW/t	12.2 kW/t
Loaded	5.4 kW/t	5.2 kW/t

SERVICE REFILL CAPACITIES	HA30	HA45
Engine oil	35 l	45 l
Fuel tank	335 l	530 l
Hub front (2x)	9.6 l	9.6 l
Tandem housing, rear differential and hubs	155 l	228 l
Hydraulic system	95 l	100 l

GROUND PRESSURE	HA30	HA45	
Tyres	Standard tyres with 15% sinkage		
Unloaded	Front Axle	122 kPa	94 kPa
	Rear Axle	52 kPa	52 kPa
Loaded	Front Axle	162 kPa	139 kPa
	Rear Axle	170 kPa	161 kPa

ARTICULATION HINGE AND CHASSIS	HA30	HA45
Articulation hinge	Articulation hinge with forward-mounted large dimensioned turning ring	
Chassis	Heavy duty design, box type welded frames; 7° sloping rear frame design	

SUSPENSION	HA30	HA45
Front	Semi-independent, self-levelling hydro-gas suspension, manually adjustable	
Rear	Free-swinging tandem housing	

NOISE	
Guaranteed noise level presented below can be differed depending on a range of factors such as operating condition, speed of a cooling fan, types of engine and so forth. Hearing protection shall be necessary if an operator is working in the improperly maintained cabin or exposed to a noisy environment by leaving doors and/or windows open.	
With cooling fan speed at maximum value:	
Operator Sound Pressure Level (ISO 6396:2008)	72 dB(A)
Exterior Sound Power Level (ISO 6395:2008)	108 dB(A)

*Distance of 15 m, moving forward in second gear rati

DIMENSIONS

DIMENSIONS

All dimensions are approximate.

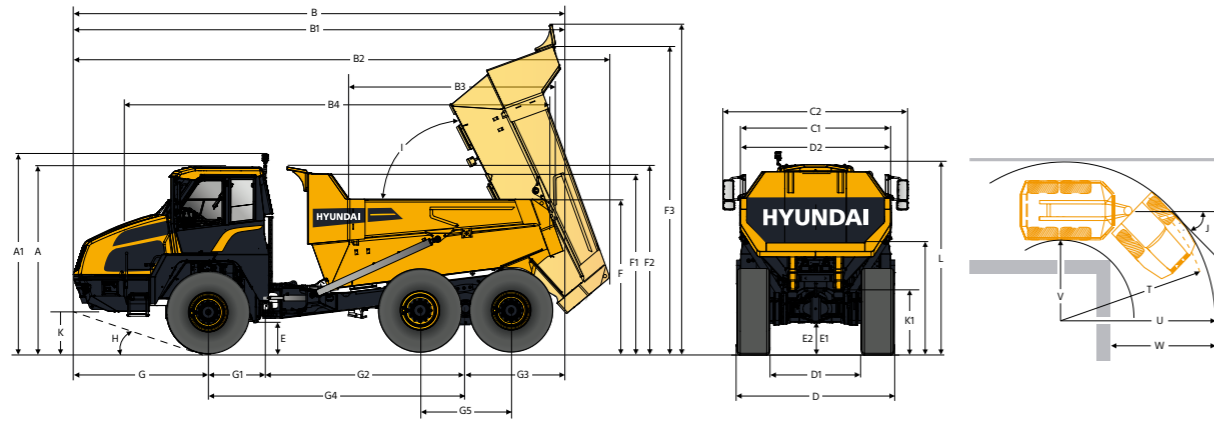

Unit: mm

Description	HA30	HA45
A Transport position / cab height	3604	3850
A1 Rotating beacon	3836	4050
B Overall w/o tailgate	9515	10633
B1 Overall with tailgate	9555	10673
B2 Overall body tipped	10405	11405
B3 Overloading height	3800	4360
C Over outside front tyre 23.5R25 / 29.5R25	3000	3475
C* Over outside front tyre 750/65R25 / 875/75R25	3208	3630
C1 Over mudguard	2860	3400
C2 Over mirror operating position	3499	3990
D Over outside rear tyres 23.5R25 / 29.5R25	3000	3475
D* Over outside rear tyres 750/65R25 / 875/75R25	3208	3630
D1 Between inner tyres	1740	1900
D2 Over body	2895	3395
E Ground clearance art. hinge	568	643
E1 Ground clearance front axle	529	625
E2 Ground clearance rear axle	540	691
E3 Ground clearance body fully tipped	619	763
F Overloading	2946	3355
F1 Body w/o rock guard	3436	3865
F2 Body with rock guard	3572	4001
F3 Body fully tipped w/o rock guard	5820	6755
F4 Body fully tipped with rock guard	6240	7170
F5 Body tip	2100	2390
G Front axle centre to machine front	2605	2818
G1 Front axle centre to art. hinge	1200	1275
G2 Art. hinge to rear axle centre	3800	4150
G3 Rear axle centre to body tip	1910	2390
G4 Front axle centre to rear axle centre	5000	5425
G5 Wheelbase rear axle	1771	1960
H Approach angle front	22.5°	26.7°
I Max. body tip angle		70°
J Max. steering angle		45°
K Front tie down height	874	1063
K1 Rear tie down height	1180	1300
L Load height (SAE 2 : 1)	3600	4100
V Inner turning radius	3995	4215
U Outer turning radius	8100	8920
T Outer wheel turning radius	8065	8880
W Corridor width	5280	5940

STANDARD/OPTIONAL EQUIPMENT

Engine

- Electronically controlled, direct injected, water-cooled, turbocharger, air-to-air intercooler
- Preheater for easier cold starts
- Exhaust brake

Hydraulic System

- 1 variable displacement piston pump for steering & tipping
- One return flow filter

Safety

- Gradient meter with anti-flip-over protection system
- Payload meter & cycle counter
- Wet disc brake
- Rear-view camera
- Hammer for emergency escape
- Hand rails on the fenders

Other

- Transmission retarder brake
- Automatic lubrication system
- Mud flaps
- Towing hook, front and rear
- HYUNDAI Connect Telematic system
- Work light kit (rear and front)
- Load weighing system

Cab & Interior

- Armrest at operator seat
- Headrest at operator seat
- Safety belt at operator and instructor seat
- Adjustable steering column
- All instrumentation in LCD display
- Cigarette lighter
- 12 V and USB charging point
- Retractable roller sunblind
- Tinted safety glass
- Sliding window (left & right side)
- Windshield wiper and washer
- Side mirrors
- Protection for rear window
- Emergency steering, ground-driven
- Radio/MP3 and Bluetooth
- Cab tilting system
- Emergency shutdown switch
- Anti-slip steps & platform
- Cool box compartment
- Storage room
- Electronic climate control
- High-comfort seat (vertical and longitudinal suspension)
- Heated operator seat

OPTIONAL EQUIPMENT

BODY

- Tailgate
- Body lining (400 HB)
- Side extension (200mm/250mm)
- Body heating kit

Safety

- Seat belt green warning light
- Blue or orange flashing reverse light
- White noise alarm
- Air inlet Pre-Cleaner
- Protection for rear lights
- Wheel block
- LED main lights
- HEPA filter package

Tires options

- Quarry
- Earthmoving
- Flotation tires

Other

- Webasto heating system (heat up the cooling system)
- Fire extinguisher
- First aid kit
- Beacon (Rotating / Foldable)
- Light bar LED
- Speed limitation
- Work light kit (rear and front) LED
- Tool kit
- Warning triangle
- Fast fill
- Tire pressure monitoring system (may not be available with all tires)
- Electrical diesel refueling pump
- Electrical adjustable heated mirror
- Electrical engine heater (230V)
- Auto grease system (6L, 20L, Beka)
- First maintenance kit
- Artic Oil
- Sign light
- Construction road sign
- CB radio
- Heated seat with 3" belt (2p/3p)