

HX260A L

With EU Stage V Engine installed

* Photo may include optional equipment.



Head Office(Sales Office)
14F, GLOBAL R&D CENTER, 477 BUNDANG SUSEO-RO, BUNDANG-GU, SEONGNAM-SI, GYEONGGI-DO, 13553, KOREA

PLEASE CONTACT

Gross Power
173 kW (232 hp) at 2,000 rpm

Net Power
169 kW (227 hp) at 2,000 rpm

Bucket Capacity
0.80 ~ 1.34 m³

Operating Weight
27,000 kg / 59,520 lb

WHAT'S NEWEST AND BEST

HX260A L

THE BEST PRODUCTIVITY AND FUEL EFFICIENCY

- EU STAGE V Engine **NEW**
- Eco Report **NEW**
- EPFC System **NEW**
- Lifting Mode **NEW**
- Fuel Rate Information
- Eco Gauge
- Automatic Engine Shut Down

ULTIMATE DURABILITY

- Side Protector **Option**
- ROPS / FOG Cabin
- Reinforced Durability of Upper and Lower Structure and Attachments
- Durable Cooling Module

EASY CONTROL AND COMFORTABLE OPERATION

- Key On Initial Work Mode **NEW**
- Visibility and Handle Improvement **NEW**
- One Pedal Travel Straight **Option**
- Proportional Auxiliary Hydraulic System **Option** (RCV Switch & Pedal control selection)
- Fine(Cushion/Free) Swing Control **Option**
- Intelligent & Wide Cluster
- Jog Dial Module
- OME(Owner Menu Editing)
- Combination Speed



THE ULTIMATE SAFE ENVIRONMENT

- Auto Safety Lock **NEW**
- Electronic Swing Parking Brake **NEW**
- AAVM **Option**
- Seatbelt Warning Alarm

SERVICEABILITY AND TELEMATICS

- ECD(Engine Connected Diagnostics) **NEW**
- Hi MATE **Option**
- Urea Tank Cover **Upgrade**
- Mobile Fleet App.
- Connected Diagnostics



THE BEST PRODUCTIVITY AND FUEL EFFICIENCY

HX A Series is equipped with eco-friendly, high-performance engines that meet the EU Stage V emission requirements.



Photo may include optional equipment

ENVIRONMENTALLY FRIENDLY FUEL EFFICIENCY

Eco Report **NEW**

It reports the excavator's inefficient operation status and help improving operator's working habit.



Fuel Rate Information

Fuel information is displayed as average rate and latest fuel consumed for guiding to economy operating.



Eco Gauge

Gauge level changes in accordance with engine working load and color indicates fuel saving-operation status.



Automatic Engine Shut Down

Adjustable 'Automatic engine shut down' significantly reduces idle time. Overall operating hours and fuel consumption.



EU STAGE V CERTIFIED ENGINE

Cummins B6.7 engine is satisfying the most strict environmental emission regulation in the world. (Reduction in PM 60%)

EU STAGE V Engine **NEW**

Now in its fourth decade of continuous improvement, the B6.7 for 2019 features an EGR-free design that delivers 5 percent more power and 31 percent more peak torque than the current model. Increased fuel economy and longer maintenance intervals contribute to a reduced cost of operation.

EU Stage-V(2019)

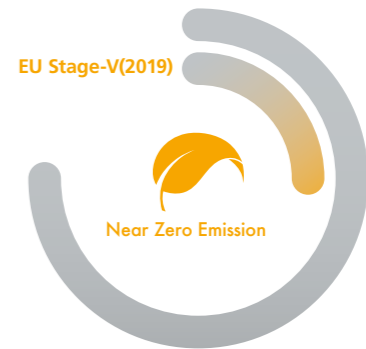

EPFC System(Electronic Pump Flow Control) **NEW**

The advanced hydraulic system and controls based on electric positive flow control system achieve the lowest fuel consumption and improved fine control. Pump power is precisely variable controlled through recognition of lever manipulation amount and specific complex operations.



Daily Fuel-efficiency
Compared to HX220L at P mode

Lifting Mode **NEW**

This work mode improves fine operability and lift capability through RPM reduction, power boost activation and pump flow control.



ULTIMATE DURABILITY

The true value of HX A Series lies in its durability and high productivity. The robust upper and lower frame structure can endure external shock and heavy work loads. Attachment performance has been proven through rigorous field testing. No matter how tough the working environment is, you can always rely on the HYUNDAI Excavator A Series.



Photo may include optional equipment.



We make the best performance in rough working conditions without any unsureness with trustworthy HX260A L.



HX A Series is equipment with eco-friendly, high-performance engines that meet the EU Stage V emission requirement. Become a true leader on the ground with HX A Series.

ROPS / FOG Cabin

The cabin structure of Hyundai HX A Series is using integrally welded low-stress, high strength steel to meet ROPS and FOG certification.

- ROPS : Roll-Over Protective Structures ISO12117-2
- FOG : Falling Object Guard, ISO10262 Level2



Reinforced Durability of Upper and Lower Structure and Attachments

The upper and lower structure and attachments of HX A Series have higher durability than demanded on the site, as proven through numerous tests including road tests and virtual simulation. The wear resistance of the bucket has been improved by use of new material.

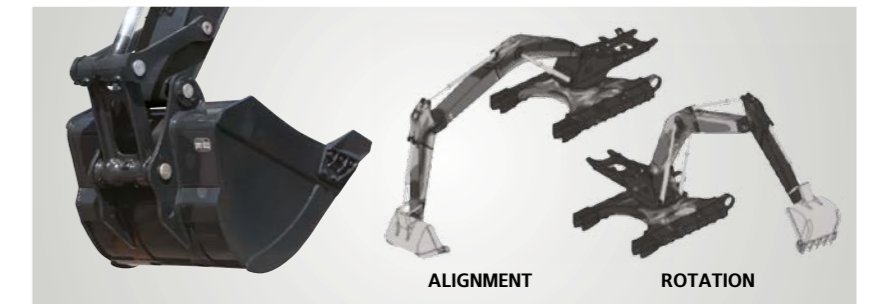

Durable Cooling Module

HX A Series has a durable cooling module that passed stringent tests, demonstrating the highest productivity in tough working environments.

Side Protector Option

Protect sides frame during operation in narrow area

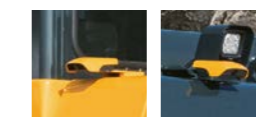

* The shape of the camera and Lamp guard may be changed to improve the performance of the equipment.

13%

CABIN SPACE FOR DRIVERS INCREASED BY
(Compared to the previous model)



310mm
340mm

EASY CONTROL AND COMFORTABLE OPERATION

Many electronic functions are concentrated in the most convenient spot for operators to improve work efficiency. The highly-advanced infotainment system, a product of HCE's intensive information technology development, enables both productivity and comfort while working! HX A Series is designed with the operator in mind.

Intelligent & Wide Cluster

The 8" capacitive-type display (like smartphone display) of HX A Series is delivering excellent legibility. The centralized switches on the display allow convenience of checking the urea level and temperature outside the cabin.

One Pedal Travel Straight Option

One Pedal straight Travel is available for customers' convenience when long distance traveling or combination of attachment work with traveling is necessary.



Proportional Auxiliary Hydraulic System Option

Proportional control switch with better speed control helps operators to enlarge the operation convenience whenever they do time-consuming work. And this function can be switched with pedal valve in cluster setting menu. Newly added detent function allows an operator to continue using 2 way piping flow even if the operator does not keep pressing proportional control switch.

Jog Dial Module

The integrated jog dial module applies to the accelerator, remote air conditioner controller and operation of the cluster, allowing convenient operation. In the event of failure of the jog dial module, the emergency mode is activated on the cluster to ensure fail-safe function.



Key On initial Work Mode NEW

Operator can maintain previously set about attachment mode when starting.



Visibility and Handle Improvement NEW

Visibility through cabin door is improved and handle design on the cabin door is also improved and offers better convenient while operator get on and off the cabin.



OME (Owner Menu Editing)

The Owner of machine can restrict operators access the set of functions. In the menu. Owner can set the list of the function to lock or unlock it. It is necessary to input the password to access the set of function.

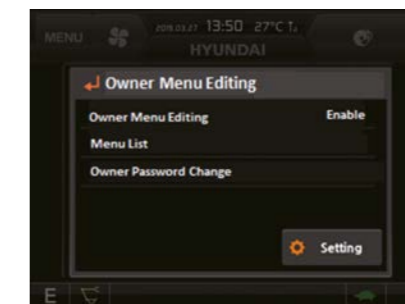

Combination Speed

Operator can set load sensitivity level, boom priority level against arm and swing. Load sensitivity is controlled by 5 levels of initial flow rate for boom-up and arm in operation according to attachment weight. Boom priority against arm and swing can be set 10 levels of boom priority against arm and swing.

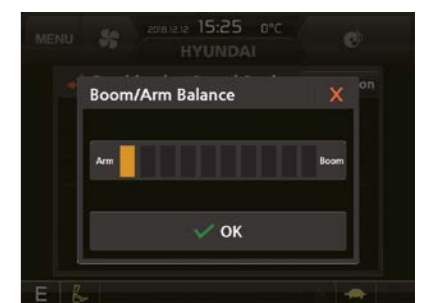
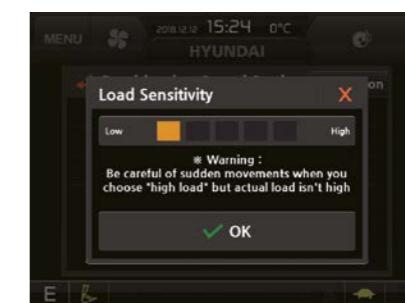

Fine (Cushion/Free) Swing Control Option

This option enables smooth movement at the start and stop of swing operation (Cushion Swing). In addition, it reduces the shaking of the weight when lifting operation (Free Swing).



HX260A L with advanced technology ensures our safety on a construction site.



HX A Series excavators are products of HCE's spirit of initiative, creativity, and strong drive. HCE engineers, who are the best in the industry, have worked tirelessly to offer a zero-defect product. The new HX A Series reflects customers' needs in the field gleaned by thorough monitoring.

AAVM(Advanced Around View Monitoring) Camera System **Option**

HX A Series has a state-of-the-art AAVM video camera system to secure field of vision for operators in all directions, thereby preventing accidents. Operators can easily check the workplace in the front and rear and to the right and left.

- **AAVM**(Advanced Around View Monitoring) : Secure field of vision in all directions by nine views including 3D bird's eye view and 2D/4CH view.
- **IMOD**(Intelligent Moving Object Detection) : Inform when people or dangerous objects are detected within the range of operation(recognition distance : 5 m).

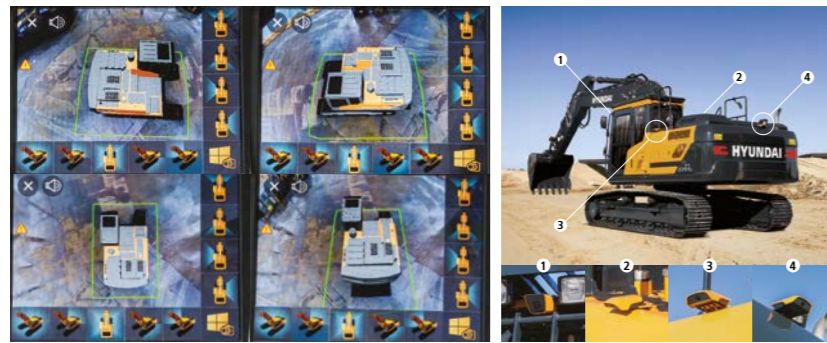

* The shape of the camera and Lamp guard may be changed to improve the performance of the equipment.

Auto Safety Lock **NEW**

It prevents unintended operation. If operator unlock safety lever when RCV lever is pressed, excavator is not controlled by RCV lever.

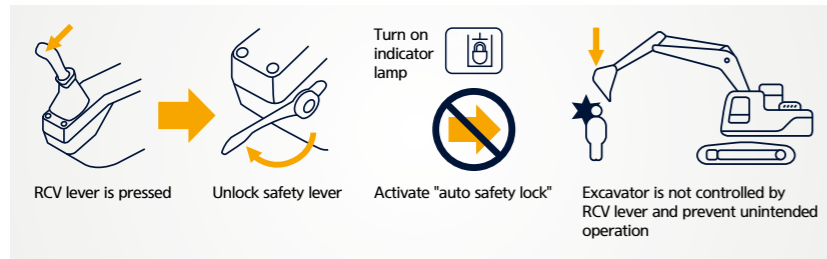

Seatbelt Warning Alarm

If the seatbelt is not buckled when the ignition key is turned, an alarm is triggered in intervals along with a continuous visual alert. This emphasises our priority for operator safety.

Electronic Swing Parking System **NEW**

An electronic valve and control system is applied to improve safety and utilization. The opening and closing time of the swing brake valve is controlled according to the sensing and control system.



THE ULTIMATE SAFE ENVIRONMENT

The true value of HX A Series lies in its durability.

The robust frame structure and the attachments show the real value of HX A Series in tough working environments and promise higher productivity.

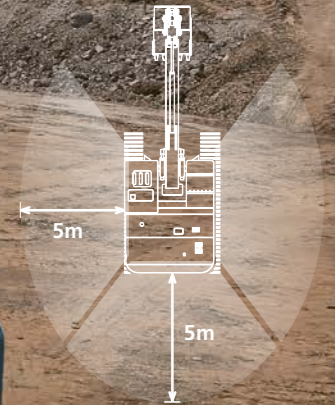



SERVICEABILITY AND TELEMATICS

IoT / ICT / AI-based digital technology. Creating a smart construction site. Maximizes connectivity, productivity, and safety for successful businesses.



Hi MATE

Option

IT'S CONVENIENT, EASY AND VALUABLE

Hi MATE Hyundai's newly developed remote management system, utilizes GPS-satellite technology to provide customers with the highest level of service and product support available. Hi MATE enables users to remotely evaluate machine performance, access diagnostic information, and verify machine locations at the touch of a button.

WHAT IS BENEFITS



Increase Productivity

It helps you operate machines in efficient. You can check the difference between total engine hours and actual working hours. See how productive your machines are and plan any required cost saving solutions. Hi MATE offers working information such as working / idling hours, fuel consumption and rate.



Convenient and Easy Monitoring

There is nothing much to do to monitor your machines. Just log on to the Hi MATE website or mobile application. Hi MATE allows you to watch your machines whenever and wherever you are.



Security

Protect your machines from theft or unauthorized usage with Hi MATE. If the machine moves out of the Geo-fence boundary, you will get alerts.

*Photo may include optional equipment.

ECD(Engine Connected Diagnostics) **NEW**

It supports service technician with remote diagnostics report and ensure it arrive on site with proper tools after preparing in advance.

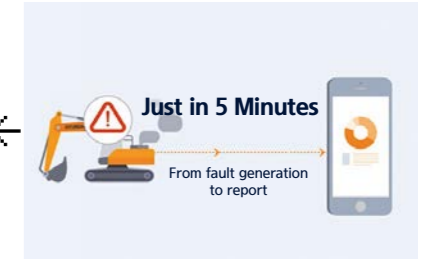
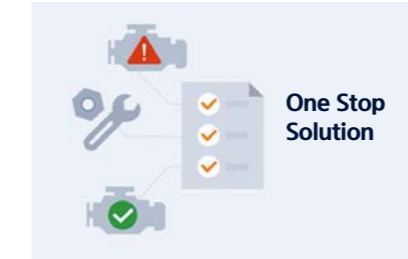

Urea Tank Cover **Upgrade**

Urea Tank Cover with full open type helps operator fill urea into the tank directly and more conveniently.



Mobile Fleet App.

The new Mobile App is optimized to fleet management. It provides productivity, health insights based on telematics technology and enables fleet owner just focus on most wanted equipment in view of economical usage, utilization, fault codes and maintenance.

The new Mobile App sorts equipment in order of eco-index, utilization-index and fault code level automatically so that urgent equipment pops up automatically.

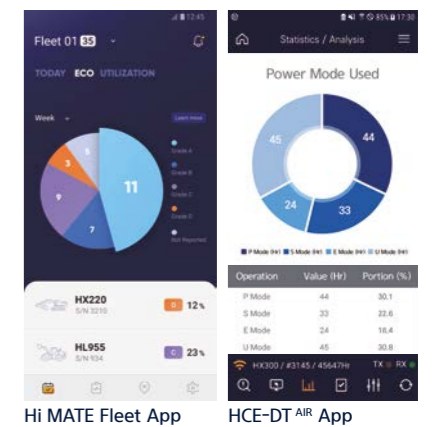

Connected Diagnostics

Engine connected diagnostics is a kind of cooperated remote diagnostics service between Cummins cloud and Hi MATE cloud. It enables you get engine diagnostics report by cloud based fault code analysis in real-time and prepare parts, tools necessary in advance. It will help increase first visit fix rates.

SPECIFICATIONS

ENGINE

Item	Specification
Maker / Model	CUMMINS / B6.7
Type	4 cylinder, watercooled, 4-cycle, turbocharged charge aircooled, direct injection, electronic controlled diesel engine
Gross Power	173kW (232hp) at 2,000rpm
Net Power	169kW (227hp) at 2,000rpm
Max. Power	173kW (232hp) at 2,000rpm
Peak Torque	949 N·m (700 lb·ft) at 1,500 rpm
Displacement	6.7 l (408 cu in)

HYDRAULIC SYSTEM

MAIN PUMP

Type	Variable Displacement Tandem Axis Piston Pumps
Max. Flow	2 × 221 lpm
Sub-Pump For Pilot Circuit	Gear Pump

Cross-sensing and fuel saving pump system.

HYDRAULIC MOTORS

Travel	Two speed axial pistons motor with brake valve and parking brake
Swing	Axial piston motor with automatic brake

RELIEF VALVE SETTING

Implement Circuits	350 kgf/cm ² (4,980 psi)
Travel	350 kgf/cm ² (4,980 psi)
Power Boost (Boom, Arm, Bucket)	380 kgf/cm ² (5,400 psi)
Swing Circuit	300 kgf/cm ² (4,267 psi)
Pilot Circuit	40 kgf/cm ² (570psi)
Service Valve	Installed

HYDRAULIC CYLINDERS

Boom cylinder	Ø135×1,395 mm
Arm cylinder	Ø145×1,620 mm
Boom cylinder (2-piece boom)	Ø135×1,345 mm
Adjust cylinder (2-piece boom)	Ø160×1,230 mm
Bucket cylinder	Ø130×1,185 mm

* Hyundai Bio Hydraulic Oil (HBHO) available.

DRIVES & BRAKES

Drive Method	Fully Hydrostatic Type
Drive Motor	Axial Piston Motor, In-Shoe Design
Reduction System	Planetary Reduction Gear
Max. Drawbar Pull	22,190 kgf (48,930 lbf)
Max. Travel Speed (High / Low)	5.6 km/hr (3.5 mph) / 3.3 km/hr (2.0 mph)
Gradeability	35° (70%)
Parking Brake	Multi Wet Disc

CONTROL

Pilot pressure operated joysticks and pedals with detachable lever provide almost effortless and fatigueless operation.	
Pilot Control	Two Joysticks with One Safety Lever (LH): Swing and Arm (RH): Boom and Bucket
Traveling And Steering	Two Levers With Pedals
Engine Throttle	Electric, Dial Type

SWING SYSTEM

Swing Motor	Fixed Displacement Axial Piston Motor
Swing Reduction	Planetary Gear Reduction
Swing Bearing Lubrication	Grease-Bathed
Swing Brake	Multi Wet Disc
Swing Speed	11.2 rpm

CAPACITIES

	liter	US gal	UK gal
Fuel Tank	450	118.9	99
Engine Coolant	40	10.6	8.8
Engine Oil	23.1	6.1	5.1
Swing Device	7	1.8	1.36
Final Drive (Each)	6	1.6	1
Hydraulic System (Including Tank)	275	72.6	60.5
Hydraulic Tank	160	42.3	34.1
DEF/AdBlue®	48	12.6	5.9

UNDERCARRIAGE

The X-leg type center frame is integrally welded with reinforced box-section track frames. The undercarriage includes lubricated rollers, idlers, track adjusters with shock absorbing springs and sprockets, and a track chain with double or triple grouser shoes.

Center Frame	X - Leg Type
Track Frame	Pentagonal Box Type
No. of Shoes on Each Side	51 EA
No. of Carrier Roller on Each Side	2 EA
No. of Track Roller on Each Side	9 EA
No. of Rail Guard on Each Side	2 EA

OPERATING WEIGHT (APPROXIMATE)

Operating weight, including 5.85m (19' 2") boom, 3.05m (10' 0") arm, SAE heaped 1.08 m³ (1.40 yd³) bucket, lubricant, coolant, full fuel tank, full hydraulic tank, and all standard equipments.

OPERATING WEIGHT

Shoes		Operating Weight	Ground Pressure
Type	Width mm (in)	kg (lb)	kgf/cm ² (psi)
Triple Grouser	600 (24")	27,000 (59,520)	0.55 (7.81)
	700 (28")	27,310 (60,210)	0.48 (6.77)
	800 (32")	27,600 (60,850)	0.42 (5.99)
	900 (36")	27,910 (61,530)	0.38 (5.39)

AIR CONDITIONING SYSTEM

The air condition system for the machine contains the fluorinated greenhouse gas with global warming potential of R134a. (Global Warming Potential : 1,430)
The system hold 0.80kg refrigerant consisting of a CO₂ of 1.14 metric tonnes. For more information, Please refer to the manual.

DIMENSIONS & WORKING RANGE

HX260A L / HX260A NL DIMENSIONS

5.85 m (19' 2") MONO BOOM and 2.1 m (6' 11"), 2.5 m (8' 2"), 3.05 m (10' 0"), 3.6 m (11' 10") ARM

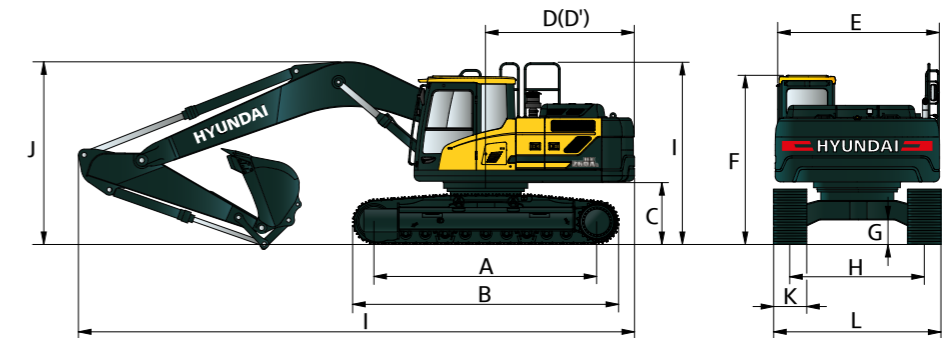

Unit : mm (ft.-in)

A Tumbler Distance	3,835 (12' 7")				
B Overall Length of Crawler	4,632 (15' 2")				
* C Ground Clearance of Counter weight	1,100 (3' 7")				
D Tail Swing Radius	3,085 (10' 1")				
D' Rear-End Length	2,990 (9' 10")				
E Overall Width of Upperstructure	2,840 (9' 4")				
* F Overall Height of Cab	3,040 (10' 0")				
* G Min. Ground Clearance	480 (1' 7")				
H Track Gauge	HX260A L 2,600 (8' 6") HX260A NL 2,380 (7' 10")				
* I Overall Height of Guardrail	3,250 (10' 8")				
Boom Length		5,850 (19' 2")			
Arm Length		2,100 (6' 11")	2,500 (8' 2")	3,050 (10' 0")	3,600 (11' 10")
I Overall Length		10,170 (33' 4")	10,070 (33' 0")	10,010 (32' 10")	10,040 (32' 11")
* J Overall Height of Boom		3,480 (11' 5")	3,360 (11' 0")	3,230 (10' 7")	3,360 (11' 0")
K Track Shoe Width		TRIPLE GROUSER			
		600 (24")	700 (28")	800 (32")	900 (36")
L Overall Width	HX260A L	3,200 (10' 6")	3,300 (10' 10")	3,400 (11' 2")	3,500 (11' 6")
	HX260A NL	2,980 (9' 9")	3,080 (10' 1")	3,180 (10' 5")	

* This figure includes the size of grousers.

HX260A L / HX260A NL WORKING RANGE

Unit : mm (ft.-in)

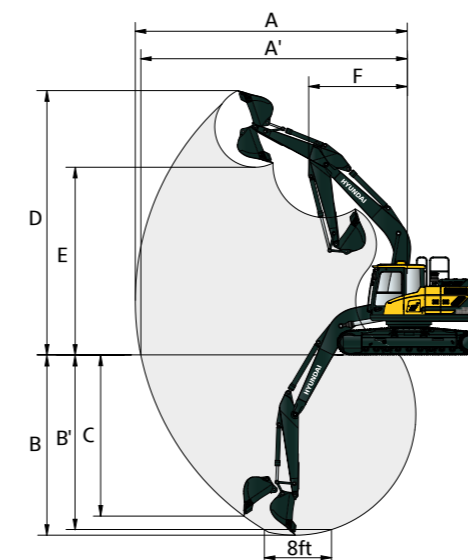

Boom Length		5,850 (19' 2")			
Arm Length		2,100 (6' 11")	2,500 (8' 2")	3,050 (10' 0")	3,600 (11' 10")
A	Max. Digging Reach	9,560 (31' 4")	9,870 (32' 5")	10,360 (34' 0")	10,870 (35' 8")
A'	Max. Digging Reach on Ground	9,370 (30' 9")	9,690 (31' 9")	10,190 (33' 5")	10,710 (35' 2")
B	Max. Digging Depth	6,060 (19' 11")	6,460 (21' 2")	7,010 (23' 0")	7,560 (24' 10")
B'	Max. Digging Depth (8' Level)	5,850 (19' 2")	6,280 (20' 7")	6,850 (22' 6")	7,420 (24' 4")
C	Max. Vertical Wall Digging Depth	5,520 (18' 1")	5,680 (18' 8")	6,170 (20' 3")	6,860 (22' 6")
D	Max. Digging Height	9,950 (32' 8")	10,020 (32' 10")	10,290 (33' 9")	10,560 (34' 8")
E	Max. Dumping Height	6,800 (22' 4")	6,900 (22' 8")	7,150 (23' 5")	7,430 (24' 5")
F	Min. Swing Radius	3,840 (12' 7")	3,190 (10' 6")	3,450 (11' 4")	3,150 (10' 4")

DIMENSIONS & WORKING RANGE

HX260A L / HX260ANL 2-PIECE BOOM DIMENSIONS

5.9 m (19' 4") 2-PIECE BOOM and 3.05 m (10' 0"), 2.1 m (6' 11"), 2.5 m (8' 2") ARM

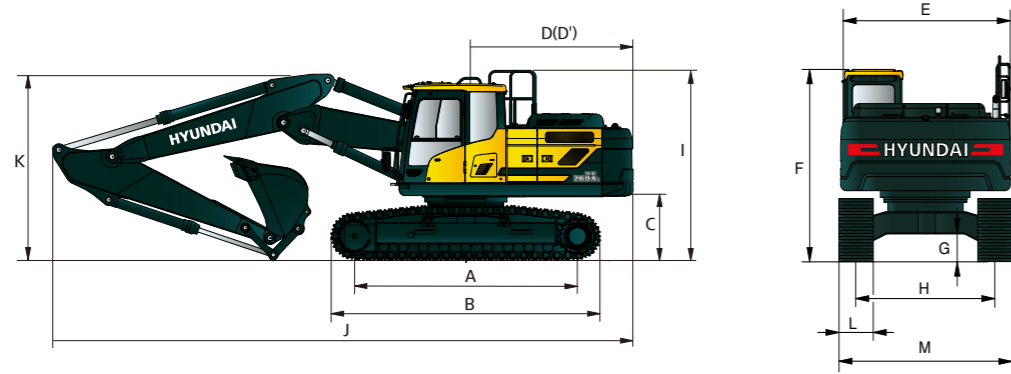

Unit : mm (ft.-in)

A Tumbler Distance	3,835 (12' 7")	Boom Length	5,900 (19' 4")				
B Overall Length of Crawler	4,632 (15' 2")	Arm Length	2,100 (6' 11")	2,500 (8' 2")	3,050 (10' 0")		
* C Ground Clearance of Counter weight	1,100 (3' 7")	I Overall Length	10,210 (33' 6")	10,110 (33' 2")	10,090 (33' 1")		
D Tail Swing Radius	3,085 (10' 1")	* K Overall Height of Boom	3,420 (11' 3")	3,360 (11' 0")	3,300 (10' 10")		
D' Rear-End Length	2,990 (9' 10")	TRIPLE GROUSER					
E Overall Width of Upperstructure	2,840 (9' 4")	K Track Shoe Width	600 (24")	700 (28")	800 (32")	900 (36")	
* F Overall Height of Cab	3,040 (10' 0")	L Overall Width	HX260A L	3,200 (10' 6")	3,300 (10' 10")	3,400 (11' 2")	3,500 (11' 6")
* G Min. Ground Clearance	480 (1' 7")		HX260A NL	2,980 (9' 9")	3,080 (10' 1")	3,180 (10' 5")	
H Track Gauge	HX260A L 2,600 (8' 6") HX260A NL 2,380 (7' 10")						
* I Overall Height of Guardrail	3,250 (10' 8")						

* This figure includes the size of grouser.

DIMENSIONS & WORKING RANGE

HX260A HIGH WALKER DIMENSIONS

5.85 m (19' 2") BOOM and 2.1 m (6' 11"), 2.5 m (8' 2"), 3.05 m (10' 0"), 3.6 m (11' 10") ARM

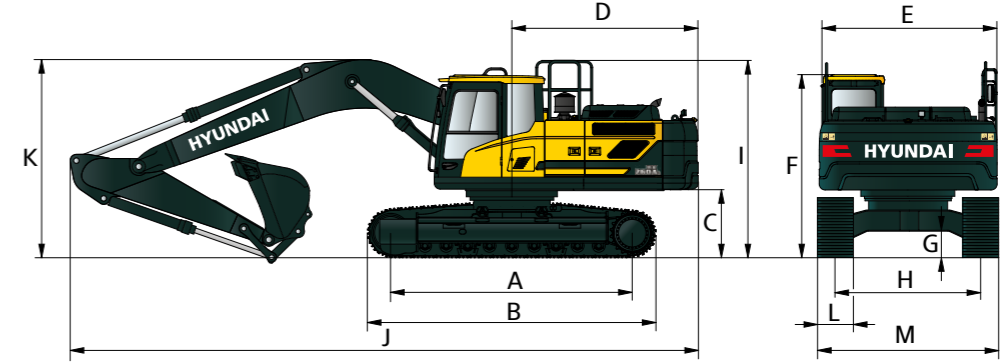

Unit : mm (ft.-in)

A Tumbler Distance	4,030 (13' 3")	Boom Length	5,850 (19' 2")			
B Overall Length of Crawler	4,940 (16' 2")	Arm Length	2,100 (6' 11")	2,500 (8' 2")	3,050 (10' 0")	3,600 (11' 10")
* C Ground Clearance of Counter weight	1,475 (4' 10")	J Overall Length	10,160 (33' 4")	10,020 (32' 10")	9,870 (32' 5")	10,040 (32' 11")
D Tail Swing Radius	2,990 (9' 10")	* K Overall Height of Boom	3,630 (11' 11")	3,460 (11' 4")	3,220 (10' 7")	3,610 (11' 10")
*** E Overall Width of Upperstructure	3,625 (11' 11")	L Track Shoe Width				
* F Overall Height of Cab	3,405 (11' 2")	Type	Triple grouser		Double grouser	
* G Min. Ground Clearance	765 (2' 6")	Width	600 (24")		700 (28")	
H Track Gauge	2,790 (9' 2")	** M Overall Width	3,470 (11' 5")		3,570 (11' 9")	
* I Overall height of guardrail	3,625 (11' 11")					

* This figure includes the size of grousers.

** without extended foot board.

*** without catwalk.

HX260A L / HX260ANL 2-PIECE BOOM WORKING RANGE

Unit : mm (ft.-in)

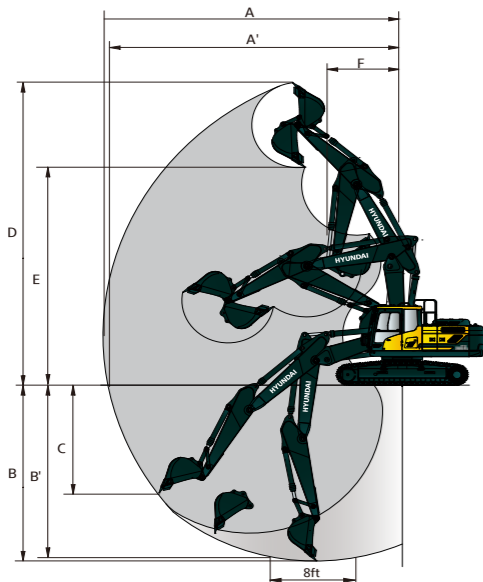

Boom Length	5,900 (19' 4")			
Arm Length	2,100 (6' 11")	2,500 (8' 2")	3,050 (10' 0")	
A Max. Digging Reach	9,660 (31' 8")	9,990 (32' 9")	10,500 (34' 5")	
A' Max. Digging Reach on Ground	9,470 (31' 1")	9,810 (32' 2")	10,320 (33' 10")	
B Max. Digging Depth	5,750 (18' 10")	6,120 (20' 1")	6,660 (21' 10")	
B' Max. Digging Depth (8' Level)	5,840 (19' 2")	6,260 (20' 6")	6,830 (22' 5")	
C Max. Vertical Wall Digging Depth	4,780 (15' 8")	5,100 (16' 9")	5,620 (18' 5")	
D Max. Digging Height	10,880 (35' 8")	11,090 (36' 5")	11,470 (37' 8")	
E Max. Dumping Height	7,660 (25' 2")	7,870 (25' 10")	8,250 (27' 1")	
F Min. Swing Radius	3,280 (10' 9")	2,990 (9' 10")	2,730 (8' 11")	

HX260A HIGH WALKER WORKING RANGE

Unit : mm (ft.-in)

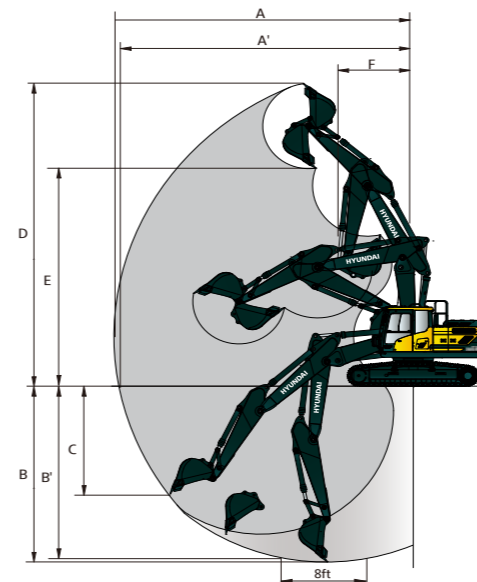

Boom length	5,850 (19' 2")			
Arm length	2,100 (6' 11")	2,500 (8' 2")	3,050 (10' 0")	3,600 (11' 10")
A Max. digging reach	9,560 (31' 4")	9,870 (32' 5")	10,360 (34' 0")	10,870 (35' 8")
A' Max. digging reach on ground	9,290 (30' 6")	9,610 (31' 6")	10,120 (33' 2")	10,640 (34' 11")
B Max. digging depth	5,700 (18' 8")	6,100 (20' 0")	6,650 (21' 10")	7,200 (23' 7")
B' Max. digging depth (8' level)	5,490 (18' 0")	5,910 (19' 5")	6,490 (21' 4")	7,050 (23' 2")
C Max. vertical digging depth	5,150 (16' 11")	5,320 (17' 5")	5,810 (19' 1")	6,500 (21' 4")
D Max. digging height	10,310 (33' 10")	10,380 (34' 1")	10,620 (34' 10")	10,920 (35' 10")
E Max. dumping height	7,160 (23' 6")	7,260 (23' 10")	7,510 (24' 8")	7,790 (25' 7")
F Min. swing radius	3,840 (12' 7")	3,190 (10' 6")	3,450 (11' 4")	3,150 (10' 4")

BUCKET SELECTION GUIDE & DIGGING FORCE

BUCKETS

All buckets are welded with high-strength steel.



SAE heaped m ³ (yd ³)	0.80 (1.05) 0.92 (1.20) 1.10 (1.44) 1.20 (1.57)	1.34 (1.75)	◆ 0.90 (1.18) ◆ 1.05 (1.37)	◆ 0.87 (1.14)	◆ 1.20 (1.57)	★ 0.52 (0.68)
---	--	-------------	--------------------------------	---------------	---------------	---------------

Capacity m ³ (yd ³)	Width mm (in)	Weight kg (lb)	Tooth (EA)	Recommendation mm (ft.in)								
				5,850 (19' 2") Mono Boom				5,900 (19' 4") 2-Piece Boom				
				2,100 (6' 11") Arm	2,500 (8' 2") Arm	3,050 (10' 0") Arm	3,600 (11' 10") Arm	2,100 (6' 11") Arm	2,500 (8' 2") Arm	3,050 (10' 0") Arm		
(G) 1.08 (1.41)	0.95 (1.24)	1,170 (46.1")	1,020 (2,250)	5	●	●	●	○	●	●	●	
(G) 1.27 (1.66)	1.11 (1.45)	1,325 (52.2")	1,100 (2,430)	5	●	●	○	■	●	●	●	
(G) 1.50 (1.96)	1.30 (1.70)	1,515 (59.6")	1,180 (2,600)	5	○	○	■	▲	●	○	○	
(H) 1.27 (1.66)	1.11 (1.45)	1,380 (54.3")	1,290 (2,840)	5	●	○	○	■	●	●	●	
(H) 1.46 (1.91)	1.28 (1.67)	1,535 (60.4")	1,380 (3,040)	6	○	■	■	▲	●	○	○	
(R) 1.16 (1.52)	1.00 (1.31)	1,285 (50.6")	1,380 (3,040)	5	●	●	○	×	●	●	●	

- (G) General Purpose ●: Applicable for materials with density of 2,100 kg/m³ (3,500 lb/yd³) or less
 (H) Heavy Duty ○: Applicable for materials with density of 1,800 kg/m³ (3,000 lb/yd³) or less
 (R) Rock-HD ■: Applicable for materials with density of 1,500 kg/m³ (2,500 lb/yd³) or less
 ▲: Applicable for materials with density of 1,200 kg/m³ (2,000 lb/yd³) or less
 ×: Not Recommended

ATTACHMENT

Booms and arms are of all-welded, low-stress, full-box section design. 5,850 mm (19' 2"), 5,900 mm (19' 4"), boom and 2,100 mm (6' 11"), 2,500 mm (8' 2"), 3,050 mm (10' 0"), 3,600 mm (11' 10") arms are available. Hyundai Bucket are all-welded, high-strength steel implements.

HX260A L MONO BOOM DIGGING FORCE

Boom	Length	mm (ft.in)	5,850 (19' 2")				Remark
	Weight	kg (lb)	2,460 (5,420)				
Arm	Length	mm (ft.in)	2,100 (6' 11")	2,500 (8' 2")	3,050 (10' 0")	3,600 (11' 10")	Remark
	Weight	kg (lb)	1,420 (3,130)	1,450 (3,200)	1,540 (3,400)	1,600 (3,530)	
Bucket Digging Force	SAE	kN	153.1 [166.1]	153.6 [167.2]	154.0 [167.2]	154.1 [167.2]	[]: Power Boost
		kgf	15,600 [16,940]	15,700 [17,050]	15,700 [17,050]	15,700 [17,050]	
		lbf	34,403 [37,350]	34,522 [37,590]	34,603 [37,590]	34,638 [37,590]	
	ISO	kN	177.2 [192.7]	177.8 [192.7]	178.2 [193.8]	178.4 [193.8]	
		kgf	18,100 [19,650]	18,100 [19,650]	18,200 [19,760]	18,200 [19,760]	
		lbf	39,819 [43,320]	39,957 [43,320]	40,051 [43,560]	40,092 [43,560]	
Arm Crowd Force	SAE	kN	159.2 [172.5]	134.3 [145.8]	113.3 [122.5]	103.1 [111.8]	
		kgf	16,200 [17,590]	13,700 [14,870]	11,500 [12,490]	10,500 [11,400]	
		lbf	35,777 [38,780]	30,188 [32,780]	25,461 [27,540]	23,170 [25,130]	
	ISO	kN	167.7 [182.1]	140.8 [153.3]	118.2 [127.8]	107.0 [116.0]	
		kgf	17,100 [18,570]	14,400 [15,630]	12,000 [13,030]	10,900 [11,830]	
		lbf	37,698 [40,940]	31,651 [34,460]	26,553 [28,730]	24,056 [26,080]	

Note : Boom weight includes arm cylinder, piping, and pin
 Arm weight includes bucket cylinder, linkage, and pin

BUCKET SELECTION GUIDE & DIGGING FORCE

HX260A L 2-PIECE BOOM DIGGING FORCE

Boom	Length	mm (ft.in)	5,900 (19' 4")			Remark
	Weight	kg (lb)	3,000 (6,610)			
Arm	Length	mm (ft.in)	2,100 (6' 11")	2,500 (8' 2")	3,050 (10' 0")	Remark
	Weight	kg (lb)	1,420 (3,130)	1,450 (3,200)	1,540 (3,400)	
Bucket Digging Force	SAE	kN	153.1 [166.1]	153.6 [167.2]	154.0 [167.2]	[]: Power Boost
		kgf	15,600 [16,940]	15,700 [17,050]	15,700 [17,050]	
		lbf	34,403 [37,350]	34,522 [37,590]	34,603 [37,590]	
	ISO	kN	177.2 [192.7]	177.8 [192.7]	178.2 [193.8]	
		kgf	18,100 [19,650]	18,100 [19,650]	18,200 [19,760]	
		lbf	39,819 [43,320]	39,957 [43,320]	40,051 [43,560]	
Arm Crowd Force	SAE	kN	159.2 [172.5]	134.3 [145.8]	113.3 [122.5]	
		kgf	16,200 [17,590]	13,700 [14,870]	11,500 [12,490]	
		lbf	35,777 [38,780]	30,188 [32,780]	25,461 [27,540]	
	ISO	kN	167.7 [182.1]	140.8 [153.3]	118.2 [127.8]	
		kgf	17,100 [18,570]	14,400 [15,630]	12,000 [13,030]	
		lbf	37,698 [40,940]	31,651 [34,460]	26,553 [28,730]	

Note : Boom weight includes arm cylinder, piping, and pin
 Arm weight includes bucket cylinder, linkage, and pin

HX260A HIGH WALKER DIGGING FORCE

Boom	Length	mm (ft.in)	5,850 (19' 2")				Remark
	Weight	kg (lb)	2,460 (5,420)				
Arm	Length	mm (ft.in)	2,100 (6' 11")	2,500 (8' 2")	3,050 (10' 0")	3,600 (11' 10")	Remark
	Weight	kg (lb)	1,420 (3,130)	1,450 (3,200)	1,540 (3,400)	1,600 (3,530)	
Bucket Digging Force	SAE	kN	153.1 [166.1]	153.6 [167.2]	154.0 [167.2]	154.1 [167.2]	[]: Power Boost
		kgf	15,600 [16,940]	15,700 [17,050]	15,700 [17,050]	15,700 [17,050]	
		lbf	34,403 [37,346]	34,522 [37,589]	34,603 [37,589]	34,638 [37,589]	
	ISO	kN	177.2 [192.7]	177.8 [192.7]	178.2 [193.8]	178.4 [193.8]	
		kgf	18,100 [19,650]	18,100 [19,650]	18,200 [19,760]	18,200 [19,760]	
		lbf	39,819 [43,321]	39,957 [43,321]	40,051 [43,563]	40,092 [43,563]	
Arm Crowd Force	SAE	kN	159.2 [172.5]	134.3 [145.8]	113.3 [122.5]	103.1 [111.8]	
		kgf	16,200 [17,590]	13,700 [14,870]	11,500 [12,490]	10,500 [11,400]	
		lbf	35,777 [38,779]	30,188 [32,783]	25,461 [27,536]	23,170 [25,133]	
	ISO	kN	167.7 [182.1]	140.8 [153.3]	118.2 [127.8]	107.0 [116.0]	
		kgf	17,100 [18,570]	14,400 [15,630]	12,000 [13,030]	10,900 [11,830]	
		lbf	37,698 [40,940]	31,651 [34,458]	26,553 [28,726]	24,056 [26,081]	

Note : Boom weight includes arm cylinder, piping, and pin
 Arm weight includes bucket cylinder, linkage, and pin

LIFTING CAPACITY

Rating over-front Rating over-side or 360 degree

HX260A L MONO BOOM

Boom 5.85 m (19' 2") / Arm 2.1 m (6' 11") / CWT 4,600kg triple grouser

Lift-point height (m/ft)	Lift-point radius								At max. reach		
	3.0 m (9.8 ft)		4.5 m (14.8 ft)		6.0 m (19.7 ft)		7.5 m (24.6 ft)		Capacity		Reach
											m(ft)
7.5m	kg								*7,270	*7,270	5.55
24.6ft	lb								*16,030	*16,030	(18.2)
6.0m	kg		*7,460	*7,460	*7,010	6,810			*7,100	5,540	6.77
19.7ft	lb		*16,450	*16,450	*15,450	15,010			*15,650	12,210	(22.2)
4.5m	kg		*9,290	*9,290	*7,660	6,580			6,940	4,610	7.49
14.8ft	lb		*20,480	*20,480	*16,890	14,510			15,300	10,160	(24.6)
3.0m	kg				*8,710	6,260	6,810	4,490	6,320	4,170	7.86
9.8ft	lb				*19,200	13,800	15,010	9,900	13,930	9,190	(25.8)
1.5m	kg				9,330	5,970	6,670	4,360	6,140	4,030	7.93
4.9ft	lb				20,570	13,160	14,700	9,610	13,540	8,880	(26.0)
0.0m	kg		*14,080	8,760	9,150	5,810	6,590	4,290	6,340	4,140	7.70
0.0ft	lb		*31,040	19,310	20,170	12,810	14,530	9,460	13,980	9,130	(25.3)
-1.5m	kg		*13,680	8,790	9,120	5,780			7,070	4,590	7.16
-4.9ft	lb		*30,160	19,380	20,110	12,740			15,590	10,120	(23.5)
-3.0m	kg	*16,680	*16,680	*12,330	8,960	*9,030	5,940		*8,540	5,700	6.20
-9.8ft	lb	*36,770	*36,770	*27,180	19,750	*19,910	13,100		*18,830	12,570	(20.4)
-4.5m	kg										
-14.8ft	lb										

Boom 5.85 m (19' 2") / Arm 2.5 m (8' 2") / CWT 4,600kg triple grouser

Lift-point height (m/ft)	Lift-point radius								At max. reach		
	3.0 m (9.8 ft)		4.5 m (14.8 ft)		6.0 m (19.7 ft)		7.5 m (24.6 ft)		Capacity		Reach
											m (ft)
7.5m	kg								*6,080	*6,080	6.00
24.6ft	lb								*13,400	*13,400	(19.7)
6.0m	kg				*6,490	*6,490			*5,660	5,130	7.14
19.7ft	lb				*14,310	*14,310			*12,480	11,310	(23.4)
4.5m	kg		*8,570	*8,570	*7,220	6,650	*6,700	4,650	*5,580	4,320	7.82
14.8ft	lb		*18,890	*18,890	*15,920	14,660	*14,770	10,250	*12,300	9,520	(25.7)
3.0m	kg		*11,080	9,640	*8,340	6,310	6,840	4,510	*5,740	3,930	8.18
9.8ft	lb		*24,430	21,250	*18,390	13,910	15,080	9,940	*12,650	8,660	(26.8)
1.5m	kg		*13,120	9,020	9,370	6,000	6,670	4,360	5,780	3,790	8.25
4.9ft	lb		*28,920	19,890	20,660	13,230	14,700	9,610	12,740	8,360	(27.1)
0.0m	kg		*13,980	8,760	9,150	5,800	6,560	4,260	5,950	3,880	8.03
0.0ft	lb		*30,820	19,310	20,170	12,790	14,460	9,390	13,120	8,550	(26.3)
-1.5m	kg	*11,520	*11,520	*13,860	8,730	9,080	5,740	6,550	6,540	4,250	7.51
-4.9ft	lb	*25,400	*25,400	*30,560	19,250	20,020	12,650	14,440	14,420	9,370	(24.6)
-3.0m	kg	*17,870	17,830	*12,810	8,860	9,180	5,830		7,980	5,140	6.61
-9.8ft	lb	*39,400	39,310	*28,240	19,530	20,240	12,850		17,590	11,330	(21.7)
-4.5m	kg			*10,080	9,220				*8,510	7,660	5.12
-14.8ft	lb			*22,220	20,330				*18,760	16,890	(16.8)

- 1 | 1 | Lifting capacity are based on ISO 10567.
- 2 | 2 | Lifting capacity of the HX Series does not exceed 75% of tipping load with the machine on firm, level ground or 87% of full hydraulic capacity.
- 3 | 3 | The Lift-point is bucket pivot mounting pin on the arm (without bucket mass).
- 4 | 4 | (*) indicates load limited by hydraulic capacity.

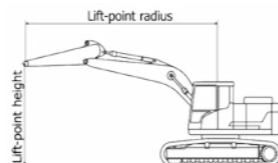

Rating over-front Rating over-side or 360 degree

HX260A L MONO BOOM

Boom 5.85 m (19' 2") / Arm 3.05 m (10' 0") / CWT 4,600kg triple grouser

Lift-point height (m/ft)	Lift-point radius										At max. reach								
	1.5 m (4.9 ft)		3.0 m (9.8 ft)		4.5 m (14.8 ft)		6.0 m (19.7 ft)		7.5 m (24.6 ft)		Capacity		Reach						
													m (ft)						
7.5m	kg																		
24.6ft	lb																		
6.0m	kg								*5,760	*5,760	*4,710	*4,710	*3,770	*3,770	7.70				
19.7ft	lb								*12,700	*12,700	*10,380	*10,380	*8,310	*8,310	(25.3)				
4.5m	kg								*7,530	*7,530	*6,560	*6,560	*6,130	4,690	*3,730	*3,730	8.34		
14.8ft	lb								*16,600	*16,600	*14,460	*14,460	*13,510	10,340	*8,220	*8,220	(27.4)		
3.0m	kg								*10,040	9,850	*7,740	6,380	*6,690	4,520	*3,830	3,570	8.67		
9.8ft	lb								*22,130	21,720	*17,060	14,070	*14,750	9,960	*8,440	7,870	(28.5)		
1.5m	kg								*12,350	9,120	*8,940	6,020	6,660	4,350	*4,100	3,440	8.74		
4.9ft	lb								*27,230	20,110	*19,710	13,270	14,680	9,590	*9,040	7,580	(28.7)		
0.0m	kg								*6,350	*6,350	*13,640	8,740	9,130	5,770	6,510	4,210	*4,570	3,500	8.53
0.0ft	lb								*14,000	*14,000	*30,070	19,270	20,130	12,720	14,350	9,280	*10,080	7,720	(28.0)
-1.5m	kg	*7,170	*7,170	*11,190	*11,190	*13,910	8,620	9,000	5,660	6,450	4,150				*5,400	3,780	8.04		
-4.9ft	lb	*15,810	*15,810	*24,670	*24,670	*30,670	19,000	19,840	12,480	14,220	9,150				*11,900	8,330	(26.4)		
-3.0m	kg	*12,120	*12,120	*17,600	17,480	*13,260	8,690	9,030	5,690						6,900	4,450	7.21		
-9.8ft	lb	*26,720	*26,720	*38,800	38,540	*29,230	19,160	19,910	12,540						15,210	9,810	(23.7)		
-4.5m	kg			*15,990	*15,990	*11,320	9,960								*8,170	6,090	5.88		
-14.8ft	lb			*35,250	*35,250	*24,960	19,750								*18,010	13,430	(19.3)		

Boom 5.85 m (19' 2") / Arm 3.6 m (11' 10") / CWT 4,600kg triple grouser

Lift-point height (m/ft)	Lift-point radius										At max. reach				
	1.5 m (4.9 ft)		3.0 m (9.8 ft)		4.5 m (14.8 ft)		6.0 m (19.7 ft)		7.5 m (24.6 ft)		9.0m (29.5ft)		Capacity	Reach	
															m (ft)
9.0m	kg														
29.5ft	lb														
7.5m	kg														
24.6ft	lb														
6.0m	kg														
19.7ft	lb														
4.5m	kg														
14.8ft	lb														
3.0m	kg														
9.8ft	lb														
1.5m	kg														
4.9ft	lb														
0.0m	kg														
0.0ft	lb														
-1.5m	kg	*6,430	*6,430	*10,500	*10,500	*13,770	8,510	8,920	5,580	6,370	4,070				
-4.9ft	lb	*14,180	*14,180	*23,150	*23,150	*30,360	18,760	19,670	12,300	14,040	8,970				
-3.0m	kg	*10,430	*10,430	*15,470	*15,470	*13,500	8,520	8,900	5,560	6,380	4,080				
-9.8ft	lb	*22,990	*22,990	*34,110	*34,110	*29,760	18,780	19,620	12,260	14,070	8,990				
-4.5m	kg	*15,500	*15,500	*17,510	*17,510	*12,140	8,710	*8,850	5,700						
-14.8ft	lb	*34,170	*34,170	*38,600	*38,600	*26,760	19,200	*19,510	12,570						
-6.0m	kg														
-19.7ft	lb														

Boom 5.85 m (19' 2") / Arm 3.05 m (10' 0") / CWT 4,600kg triple grouser

Lift-point height (m/ft)	Lift-point radius										At max. reach		
	1.5 m (4.9 ft)		3.0 m (9.8 ft)		4.5 m (14.8 ft)		6.0 m (19.7 ft)		7.5 m (24.6 ft)		Capacity		Reach

LIFTING CAPACITY

Rating over-front Rating over-side or 360 degree

HX260A L 2-PIECE BOOM

Boom 5.90 m (19' 4") / Arm 2.1 m (6' 11") / CWT 6,100kg triple grouser

Lift-point height (m/ft)	Lift-point radius								At max. reach			
	3.0 m (9.8 ft)		4.5 m (14.8 ft)		6.0 m (19.7 ft)		7.5 m (24.6 ft)		Capacity		Reach	
											m (ft)	
9.0m 29.5ft	kg									*11,320	*11,320	3.57
	lb									*24,960	*24,960	(11.7)
7.5m 24.6ft	kg		*8,710	*8,710						*7,630	*7,630	5.70
	lb		*19,200	*19,200						*16,820	*16,820	(18.7)
6.0m 19.7ft	kg		*9,100	*9,100	*7,120	*7,120				*6,480	6,130	6.89
	lb		*20,060	*20,060	*15,700	*15,700				*14,290	13,510	(22.6)
4.5m 14.8ft	kg		*10,840	*10,840	*7,500	7,500	*6,040	5,280		*5,990	5,150	7.60
	lb		*23,900	*23,900	*16,710	16,530	*13,320	11,640		*13,210	11,350	(24.9)
3.0m 9.8ft	kg				*8,480	7,140	*6,230	5,150		*5,850	4,690	7.97
	lb				*18,700	15,740	*13,730	11,350		*12,900	10,340	(26.1)
1.5m 4.9ft	kg				*9,570	6,840	*6,560	5,020		*5,970	4,550	8.04
	lb				*21,100	15,080	*14,460	11,070		*13,160	10,030	(26.4)
0.0m 0.0ft	kg				*9,900	6,670	*6,830	4,940		*6,390	4,690	7.81
	lb				*21,830	14,700	*15,060	10,890		*14,090	10,340	(25.6)
-1.5m -4.9ft	kg		*11,140	10,100	*8,730	6,660				*6,370	5,190	7.28
	lb		*24,560	22,270	*19,250	14,680				*14,040	11,440	(23.9)
-3.0m -9.8ft	kg											
	lb											

Boom 5.90 m (19' 4") / Arm 2.5 m (8' 2") / CWT 6,100kg triple grouser

Lift-point height (m/ft)	Lift-point radius								At max. reach			
	3.0 m (9.8 ft)		4.5 m (14.8 ft)		6.0 m (19.7 ft)		7.5 m (24.6 ft)		Capacity		Reach	
											m (ft)	
9.0m 29.5ft	kg									*7,520	*7,520	4.28
	lb									*16,580	*16,580	(14.0)
7.5m 24.6ft	kg		*8,210	*8,210	*6,850	*6,850				*6,110	*6,110	6.17
	lb		*18,100	*18,100	*15,100	*15,100				*13,470	*13,470	(20.2)
6.0m 19.7ft	kg		*8,600	*8,600	*6,780	*6,780				*5,630	*5,630	7.28
	lb		*18,960	*18,960	*14,950	*14,950				*12,410	*12,410	(23.9)
4.5m 14.8ft	kg		*10,090	*10,090	*7,250	*7,250	*5,750	5,330		*5,480	4,830	7.95
	lb		*22,240	*22,240	*15,980	*15,980	*12,680	11,750		*12,080	10,650	(26.1)
3.0m 9.8ft	kg		*13,070	10,950	*8,130	7,210	*6,010	5,180		*5,370	4,420	8.30
	lb		*28,810	24,140	*17,920	15,900	*13,250	11,420		*11,840	9,740	(27.2)
1.5m 4.9ft	kg		*13,890	10,290	*9,240	6,870	*6,380	5,020		*5,490	4,280	8.37
	lb		*30,620	22,690	*20,370	15,150	*14,070	11,070		*12,100	9,440	(27.5)
0.0m 0.0ft	kg		*13,360	10,030	*10,020	6,670	*6,700	4,910		*5,860	4,390	8.16
	lb		*29,450	22,110	*22,090	14,700	*14,770	10,820		*12,920	9,680	(26.8)
-1.5m -4.9ft	kg	*10,210	*10,210	*11,810	10,030	*9,100	6,610	*6,640	4,920	*6,320	4,810	7.64
	lb	*22,510	*22,510	*26,040	22,110	*20,060	14,570	*14,640	10,850	*13,930	10,600	(25.1)
-3.0m -9.8ft	kg		*9,180	*9,180	*6,990	6,730				*5,430	*5,430	6.76
	lb		*20,240	*20,240	*15,410	14,840				*11,970	*11,970	(22.2)

Boom 5.90 m (19' 4") / Arm 3.05 m (10' 0") / CWT 6,100kg triple grouser

Lift-point height (m/ft)	Lift-point radius										At max. reach		
	3.0 m (9.8 ft)		4.5 m (14.8 ft)		6.0 m (19.7 ft)		7.5 m (24.6 ft)		9.0 m (29.5 ft)		Capacity		Reach
													m (ft)
9.0m 29.5ft	kg		*6,440	*6,440							*4,710	*4,710	5.21
	lb		*14,200	*14,200							*10,380	*10,380	(17.1)
7.5m 24.6ft	kg				*6,190	*6,190					*4,000	*4,000	6.84
	lb				*13,650	*13,650					*8,820	*8,820	(22.4)
6.0m 19.7ft	kg		*6,880	*6,880	*6,340	*6,340	*5,290	*5,290			*3,720	*3,720	7.85
	lb		*15,170	*15,170	*13,980	*13,980	*11,660	*11,660			*8,200	*8,200	(25.8)
4.5m 14.8ft	kg	*12,620	*12,620	*9,150	*9,150	*6,790	*6,790	*5,400	5,380		*3,650	*3,650	8.48
	lb	*27,820	*27,820	*20,170	*20,170	*14,970	*14,970	*11,900	11,860		*8,050	*8,050	(27.8)
3.0m 9.8ft	kg		*11,860	11,190	*7,620	7,280	*5,700	5,200			*3,710	*3,710	8.81
	lb		*26,150	24,670	*16,800	16,050	*12,570	11,460			*8,180	*8,180	(28.9)
1.5m 4.9ft	kg		*13,630	10,410	*8,720	6,900	*6,090	5,000			*3,920	3,890	8.87
	lb		*30,050	22,950	*19,220	15,210	*13,430	11,020			*8,640	8,580	(29.1)
0.0m 0.0ft	kg		*13,620	10,010	*9,800	6,640	*6,470	4,860			*4,310	3,970	8.67
	lb		*30,030	22,070	*21,610	14,640	*14,260	10,710			*9,500	8,750	(28.5)
-1.5m -4.9ft	kg	*10,150	*10,150	*12,500	9,910	*9,440	6,530	*6,710	4,810		*4,990	4,290	8.19
	lb	*22,380	*22,380	*27,560	21,850	*20,810	14,400	*14,790	10,600		*11,000	9,460	(26.9)
-3.0m -9.8ft	kg		*10,300	10,010	*7,860	6,580					*5,430	5,010	7.38
	lb		*22,710	22,070	*17,330	14,510					*11,970	11,050	(24.2)

1 | 1 | Lifting capacity are based on ISO 10567.

2 | 2 | Lifting capacity of the HX Series does not exceed 75% of tipping load with the machine on firm, level ground or 87% of full hydraulic capacity.

3 | 3 | The Lift-point is bucket pivot mounting pin on the arm(without bucket mass).

4 | 4 | (*) indicates load limited by hydraulic capacity.

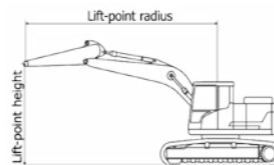

Rating over-front Rating over-side or 360 degree

HX260A NL MONO BOOM

Boom 5.85 m (19' 2") / Arm 2.1 m (6' 11") / CWT 6,100kg triple grouser

Lift-point height (m/ft)	Lift-point radius								At max. reach					
	3.0 m (9.8 ft)		4.5 m (14.8 ft)		6.0 m (19.7 ft)		7.5 m (24.6 ft)		Capacity		Reach			
											m (ft)			
7.5m 24.6ft	kg									*7,280	*7,280	5.50		
	lb									*16,050	*16,050	(18.1)		
6.0m 19.7ft	kg			*7,430	*7,430	*7,000	6,570			*7,110	5,390	6.74		
	lb			*16,380	*16,380	*15,430	14,480			*15,670	11,880	(22.1)		
4.5m 14.8ft	kg			*9,220	*9,220	*7,630	6,350			*7,160	4,470	7.47		
	lb			*20,330	*20,330	*16,820	14,000			*15,790	9,850	(24.5)		
3.0m 9.8ft	kg					*8,680	6,030	7,100	4,350			6,600	4,040	7.85
	lb					*19,140	13,290	15,650	9,590			14,550	8,910	(25.8)
1.5m 4.9ft	kg					*9,680	5,750	6,960	4,220			6,400	3,890	7.93
	lb					*21,340	12,680	15,340	9,300			14,110	8,580	(26.0)
0.0m 0.0ft	kg			*14,080	8,340	9,540	5,590	6,870	4,140			6,610	3,990	7.72
	lb			*31,040	18,390	21,030	12,320	15,150	9,130			14,570	8,800	(25.3)
-1.5m -4.9ft	kg			*13,700	8,360	9,510	5,560					7,340	4,410	7.18
	lb			*30,200	18,430	20,970	12,260					16,180	9,720	(23.6)
-3.0m -9.8ft	kg	*16,760	16,720	*12,390	8,530	*9,090	5,700					*8,530	5,440	6.24
	lb	*36,950	36,860	*27,320	18,810	*20,040	12,570					*18,810	11,990	(20.5)
-4.5m -14.8ft	kg													
	lb													

Boom 5.85 m (19' 2") / Arm 2.5 m (8' 2") / CWT 6,100kg triple grouser

Lift-point height (m/ft)	Lift-point radius								At max. reach			
	3.0 m (9.8 ft)		4.5 m (14.8 ft)		6.0 m (19.7 ft)		7.5 m (24.6 ft)		Capacity		Reach	
											m (ft)	
7.5m 24.6ft	kg									*6,100	*6,100	5.96
	lb									*13,450	*13,450	(19.5)
6.0m 19.7ft	kg					*6,480	*6,480			*5,660	4,990	7.11</

LIFTING CAPACITY

Rating over-front Rating over-side or 360 degree

HX260A NL MONO BOOM

Boom 5.85 m (19' 2") / Arm 3.05 m (10' 0") / CWT 6,100kg triple grouser

Lift-point height (m/ft)	Lift-point radius										At max. reach			
	1.5m (4.9ft)		3.0m (9.8ft)		4.5m (14.8ft)		6.0m (19.7ft)		7.5m (24.6ft)		Capacity		Reach	
													m (ft)	
7.5m 24.6ft	kg lb													
6.0m 19.7ft	kg lb													
4.5m 14.8ft	kg lb													
3.0m 9.8ft	kg lb													
1.5m 4.9ft	kg lb													
0.0m 0.0ft	kg lb													
-1.5m -4.9ft	kg lb													
-3.0m -9.8ft	kg lb													
-4.5m -14.8ft	kg lb													

Boom 5.85 m (19' 2") / Arm 3.6 m (11' 10") / CWT 6,100kg triple grouser

Lift-point height (m/ft)	Lift-point radius										At max. reach				
	1.5 m (4.9 ft)		3.0 m (9.8 ft)		4.5 m (14.8 ft)		6.0 m (19.7 ft)		7.5 m (24.6 ft)		9.0 m (29.5 ft)		Capacity		Reach
															m (ft)
9.0m 29.5ft	kg lb														
7.5m 24.6ft	kg lb														
6.0m 19.7ft	kg lb														
4.5m 14.8ft	kg lb														
3.0m 9.8ft	kg lb														
1.5m 4.9ft	kg lb														
0.0m 0.0ft	kg lb														
-1.5m -4.9ft	kg lb														
-3.0m -9.8ft	kg lb														
-4.5m -14.8ft	kg lb														
-6.0m -19.7ft	kg lb														

- 1 | Lifting capacity are based on ISO 10567.
- 2 | Lifting capacity of the HX Series does not exceed 75% of tipping load with the machine on firm, level ground or 87% of full hydraulic capacity.
- 3 | The Lift-point is bucket pivot mounting pin on the arm(without bucket mass).
- 4 | (*) indicates load limited by hydraulic capacity.

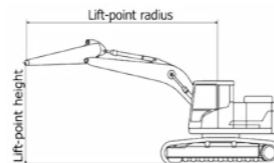

Rating over-front Rating over-side or 360 degree

HX260A NL 2-PIECE BOOM

Boom 5.90 m (19' 4") / Arm 2.1 m (6' 11") / CWT 6,100kg triple grouser

Lift-point height (m/ft)	Lift-point radius										At max. reach			
	3.0 m (9.8 ft)		4.5 m (14.8 ft)		6.0 m (19.7 ft)		7.5 m (24.6 ft)		Capacity		Reach			
													m (ft)	
9.0m 29.5ft	kg lb													
7.5m 24.6ft	kg lb													
6.0m 19.7ft	kg lb													
4.5m 14.8ft	kg lb													
3.0m 9.8ft	kg lb													
1.5m 4.9ft	kg lb													
0.0m 0.0ft	kg lb													
-1.5m -4.9ft	kg lb													
-3.0m -9.8ft	kg lb													

Boom 5.90 m (19' 4") / Arm 2.5 m (8' 2") / CWT 6,100kg triple grouser

Lift-point height (m/ft)	Lift-point radius										At max. reach			
	3.0 m (9.8 ft)		4.5 m (14.8 ft)		6.0 m (19.7 ft)		7.5 m (24.6 ft)		Capacity		Reach			
													m (ft)	
9.0m 29.5ft	kg lb													
7.5m 24.6ft	kg lb													
6.0m 19.7ft	kg lb													
4.5m 14.8ft	kg lb													
3.0m 9.8ft	kg lb													
1.5m 4.9ft	kg lb													
0.0m 0.0ft	kg lb													
-1.5m -4.9ft	kg lb													
-3.0m -9.8ft	kg lb													

Boom 5.90 m (19' 4") / Arm 3.05 m (10' 0") / CWT 6,100kg triple grouser

Lift-point height (m/ft)	Lift-point radius										At max. reach			
	3.0m (9.8ft)		4.5m (14.8ft)		6.0m (19.7ft)		7.5m (24.6ft)		9.0m (29.5ft)		Capacity		Reach	
													m (ft)	
9.0m 29.5ft	kg lb													
7.5m 24.6ft	kg lb													
6.0m 19.7ft	kg lb													
4.5m 14.8ft	kg lb													
3.0m 9.8ft	kg lb													
1.5m 4.9ft	kg lb													
0.0m 0.0ft	kg lb													
-1.5m -4.9ft	kg lb													
-3.0m -9.8ft	kg lb													

- 1 | Lifting capacity are based on ISO 10567.
- 2 | Lifting capacity of the HX Series does not exceed 75% of tipping load with the machine on firm, level ground or 87% of full hydraulic capacity.
- 3 | The Lift-point is bucket pivot mounting pin on the arm(without bucket mass).
- 4 | (*) indicates load limited by hydraulic capacity.

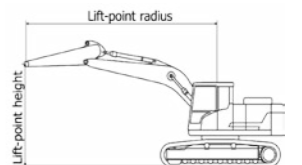

LIFTING CAPACITY

Rating over-front Rating over-side or 360 degree

HX260A HIGH WALKER

Boom 5.85 m (19' 2") / Arm 2.1 m (6' 11") / CWT 6,100kg triple grouser

Lift-point height (m/ft)	Lift-point radius								At max. reach			
	3.0 m (9.8 ft)		4.5 m (14.8 ft)		6.0 m (19.7 ft)		7.5 m (24.6 ft)		Capacity		Reach	
											m (ft)	
7.5m 24.6ft	kg lb								*7,190 *15,850	*7,190 *15,850	5.91 (19.4)	
6.0m 19.7ft	kg lb		*7,800 *17,200	*7,800 *17,200	*7,100 *15,650	*7,100 *15,650			*7,110 *15,670	6.64 14,640	6.98 (22.9)	
4.5m 14.8ft	kg lb		*9,880 *21,780	*9,880 *21,780	*7,900 *17,420	*7,900 *17,420	*7,200 *15,870	5.840 12,870	*7,200 *15,870	5.700 12,570	7.61 (25.0)	
3.0m 9.8ft	kg lb				*8,980 *19,800	7,900 17,420	*7,580 *16,710	5,710 12,590	*7,400 *16,310	5,280 11,640	7.90 (25.9)	
1.5m 4.9ft	kg lb				*9,890 *21,800	7,630 16,820	*8,000 *17,640	5,590 12,320	7,580 16,710	5,200 11,460	7.90 (25.9)	
0.0m 0.0ft	kg lb			*14,060 *31,000	11,430 25,200	*10,320 *22,750	7,500 16,530	8,120 17,900	5,540 12,210	7,970 17,570	5,440 11,990	7.60 (24.9)
-1.5m -4.9ft	kg lb	*13,230 *29,170	*13,230 *29,170	*13,460 *29,670	11,500 25,350	*10,060 *22,180	7,510 16,560		*8,330 *18,360	6,160 13,580	6.97 (22.9)	
-3.0m -9.8ft	kg lb	*15,910 *35,080	*15,910 *35,080	*11,770 *25,950	11,730 25,860				*8,570 *18,890	7,940 17,500	5.89 (19.3)	
-4.5m -14.8ft	kg lb											

Boom 5.85 m (19' 2") / Arm 2.5 m (8' 2") / CWT 6,100kg triple grouser

Lift-point height (m/ft)	Lift-point radius								At max. reach			
	3.0 m (9.8 ft)		4.5 m (14.8 ft)		6.0 m (19.7 ft)		7.5 m (24.6 ft)		Capacity		Reach	
											m (ft)	
7.5m 24.6ft	kg lb					*6,460 *14,240	*6,460 *14,240			*5,930 *13,070	*5,930 *13,070	6.33 (20.8)
6.0m 19.7ft	kg lb					*6,610 *14,570	*6,610 *14,570			*5,610 *12,370	*5,610 *12,370	7.34 (24.1)
4.5m 14.8ft	kg lb		*9,150 *20,170	*9,150 *20,170	*7,470 *16,470	*7,470 *16,470	*6,790 *14,970	5.880 12,960	*5,600 *12,350	5,360 11,820	7.94 (26.0)	
3.0m 9.8ft	kg lb		*11,670 *25,730	*11,670 *25,730	*8,620 *19,000	7,950 17,530	*7,290 *16,070	5,730 12,630	*5,820 *12,830	4,990 11,000	8.22 (27.0)	
1.5m 4.9ft	kg lb		*13,440 *29,630	11,610 25,600	*9,640 *21,250	7,650 16,870	*7,800 *17,200	5,590 12,320	*6,300 *13,890	4,900 10,800	8.22 (27.0)	
0.0m 0.0ft	kg lb			*14,030 *30,930	11,410 25,150	*10,220 *22,530	7,480 16,490	8,080 17,810	5,500 12,130	*7,160 *15,790	5,100 11,240	7.93 (26.0)
-1.5m -4.9ft	kg lb	*13,520 *29,810	*13,520 *29,810	*13,700 *30,200	11,420 25,180	*10,170 *22,420	7,460 16,450		*8,010 *17,660	5,690 12,540	7.33 (24.0)	
-3.0m -9.8ft	kg lb	*17,170 *37,850	*17,170 *37,850	*12,370 *27,270	11,610 25,600	*9,070 *20,000	7,600 16,760		*8,390 *18,500	7,110 15,670	6.31 (20.7)	
-4.5m -14.8ft	kg lb											

- 1 | Lifting capacity are based on ISO 10567.
- 2 | Lifting capacity of the HX Series does not exceed 75% of tipping load with the machine on firm, level ground or 87% of full hydraulic capacity.
- 3 | The Lift-point is bucket pivot mounting pin on the arm(without bucket mass).
- 4 | (*) indicates load limited by hydraulic capacity.

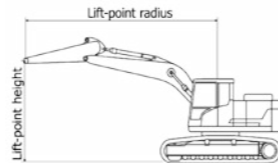

Rating over-front Rating over-side or 360 degree

HX260A HIGH WALKER

Boom 5.85 m (19' 2") / Arm 3.05 m (10' 0") / CWT 6,100kg triple grouser

Lift-point height (m/ft)	Lift-point radius										At max. reach			
	1.5 m (4.9 ft)		3.0 m (9.8 ft)		4.5 m (14.8 ft)		6.0 m (19.7 ft)		7.5 m (24.6 ft)		Capacity		Reach	
													m (ft)	
9.0m 29.5ft	kg lb											*4,450 *9,810	*4,450 *9,810	5.47 (18.0)
7.5m 24.6ft	kg lb							*5,580 *12,300	*5,580 *12,300			*3,920 *8,640	*3,920 *8,640	6.96 (22.8)
6.0m 19.7ft	kg lb							*5,910 *13,030	*5,910 *13,030	*5,370 *11,840	*5,370 *11,840	*3,740 *8,250	*3,740 *8,250	7.89 (25.9)
4.5m 14.8ft	kg lb			*11,340 *25,000	*11,340 *25,000	*8,090 *17,840	*8,090 *17,840	*6,830 *15,060	*6,830 *15,060	*6,250 *13,780	5,920 13,050	*3,740 *8,250	*3,740 *8,250	8.45 (27.7)
3.0m 9.8ft	kg lb					*10,660 *23,500	*10,660 *23,500	*8,050 *17,750	8,010 17,660	*6,850 *15,100	5,740 12,650	*3,880 *8,550	*3,880 *8,550	8.71 (28.6)
1.5m 4.9ft	kg lb					*12,770 *28,150	11,690 25,770	*9,200 *20,280	7,670 16,910	*7,470 *16,470	5,560 12,260	*4,190 *9,240	*4,190 *9,240	8.71 (28.6)
0.0m 0.0ft	kg lb			*7,440 *16,400	*7,440 *16,400	*13,790 *30,400	11,370 25,070	*9,970 *21,980	7,440 16,400	*7,910 *17,440	5,440 11,990	*4,730 *10,430	*4,730 *10,430	8.44 (27.7)
-1.5m -4.9ft	kg lb	*8,340 *18,390	*8,340 *18,390	*12,560 *27,690	*12,560 *27,690	*13,840 *30,510	11,300 24,910	*10,180 *22,440	7,360 16,230	*7,920 *17,460	5,410 11,930	*5,700 *12,570	*5,700 *12,570	7.88 (25.8)
-3.0m -9.8ft	kg lb	*13,470 *29,700	*13,470 *29,700	*18,550 *40,900	*18,550 *40,900	*12,940 *28,530	11,420 25,180	*9,570 *21,100	7,430 16,380			*7,730 *17,040	6,100 13,450	6.94 (22.8)
-4.5m -14.8ft	kg lb			*14,840 *32,720	*14,840 *32,720	*10,490 *23,130	*10,490 *23,130					*8,240 *18,170	*8,240 *18,170	5.45 (17.9)

Boom 5.85 m (19' 2") / Arm 3.6 m (11' 10") / CWT 6,100kg triple grouser

Lift-point height (m/ft)	Lift-point radius										At max. reach						
	1.5 m (4.9 ft)		3.0 m (9.8 ft)		4.5 m (14.8 ft)		6.0 m (19.7 ft)		7.5 m (24.6 ft)		9.0 m (29.5 ft)		Capacity		Reach		
															m (ft)		
9.0m 29.5ft	kg lb											*4,470 *9,850	*4,470 *9,850		*3,790 *8,360	*3,790 *8,360	6.26 (20.5)
7.5m 24.6ft	kg lb									*3,730 *8,220	*3,730 *8,220			*3,410 *7,520	*3,410 *7,520	7.59 (24.9)	
6.0m 19.7ft	kg lb							*5,190 *11,440	*5,190 *11,440	*5,280 *11,640	*5,280 *11,640			*3,260 *7,190	*3,260 *7,190	8.45 (27.7)	
4.5m 14.8ft	kg lb							*6,140 *13,540	*6,140 *13,540	*5,720 *12,610	*5,720 *12,610			*3,260 *7,190	*3,260 *7,190	8.97 (29.4)	
3.0m 9.8ft	kg lb					*9,590 *21,140	*9,590 *21,140	*7,420 *16,360	*7,420 *16,360	*6,390 *14,090	5,750 12,680	*4,480 *9,880	4,320 9,520	*3,380 *7,450	*3,380 *7,450	9.22 (30.3)	
1.5m 4.9ft	kg lb					*11,960 *26,370	11,780 25,970	*8,680 *19,140	7,680 16,930	*7,090 *15,630	5,540 12,210	*4,900 *10,800	4,220 9,300	*3,620 *7,980	*3,620 *7,980	9.22 (30.3)	
0.0m 0.0ft	kg lb			*7,780 *17,150	*7,780 *17,150	*13,360 *29,450	11,330 24,980	*9,630 *21,230	7,400 16,310	*7,650 *16,870	5,390 11,880			*4,040 *8,910	*4,040 *8,910	8.97 (29.4)	
-1.5m -4.9ft	kg lb	*7,360 *16,230	*7,360 *16,230	*11,550 *25,460	*11,550 *25,460	*13,780 *30,380	11,170 24,630	*10,060 *22,180	7,270 16,030	*7,880 *17,370	5,310 11,710			*4,770 *10,520	*4,770 *10,520	8.44 (27.7)	
-3.0m -9.8ft	kg lb	*11,530 *25,420	*11,530 *25,420	*17,020 *37,520	*17,020 *37,520	*13,290 *29,300	11,230 24,760	*9,800 *21,610	7,280 16,050	*7,090 *15,630	5,370 11,840			*6,160 *13,580	*6,160 *13,580	7.58 (24.9)	
-4.5m -14.8ft	kg lb			*16,600 *36,600	*16,600 *36,600	*11,550 *25,460	11,480 25,310	*8,270 *18,230	7,500 16,530					*7,760 *17,110	7,110 15,670	6.24 (20.5)	

- 1 | Lifting capacity are based on ISO 10567.
- 2 | Lifting capacity of the HX Series does not exceed 75% of tipping load with the machine on firm, level ground or 87% of full hydraulic capacity.
- 3 | The Lift-point is bucket pivot mounting pin on the arm(without bucket mass).
- 4 | (*) indicates load limited by hydraulic capacity.

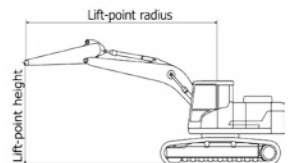

STANDARD / OPTIONAL

ENGINE	STD	OPT
Cummins B6.7	●	
HYDRAULIC SYSTEM		
Electronic Pump Flow Control (EPFC)		
3-Power Mode, 2-Work Mode, User Mode	●	
Variable Power Control	●	
Pump Flow Control	●	
Attachment Mode Flow Control		●
Engine Auto Idle	●	
Electronic Swing Parking Brake		●
Engine Auto Shutdown Control		●
Electronic Fan Control	●	
Hyundai Bio Hydraulic oil (HBHO)		●
CAB & INTERIOR		
ISO Standard cabin		
Rise-Up Type Windshield Wiper	●	
Radio / USB Player	●	
Handsfree Mobile Phone System with USB	●	
12V Power Outlet (24V DC to 12V DC converter)	●	
Electric Horn	●	
All-Weather Steel Cab with 360° Visibility	●	
Safety Glass - Tempered Glass	●	
Safety Glass - Laminated Glass, Front Window & Glass		●
Sliding Fold-In Front Window	●	
Sliding Side Window (LH)	●	
Lockable Door	●	
Hot & Cool Box	●	
Storage Compartment	●	
Ashtray & Cigar Lighter		●
Transparent Cabin Roof-Cover	●	
Sun Visor	●	
Door And Cab Locks, One Key	●	
Mechanical Suspension Seat With Heater	●	
Pilot-Operated Slidable Joystick	●	
Console Box Height Adjust System	●	
Automatic climate control		
Air Conditioner & Heater	●	
Defroster	●	
Starting Aid (Air Grid Heater) for Cold Weather	●	
Centralized monitoring		
8" LCD Display	●	
Engine Speed or Trip Meter / Accel.	●	
Engine Coolant Temperature Gauge	●	
Max Power	●	
Low Speed / High Speed	●	
Auto Idle	●	
Overload	●	
Check Engine	●	
Air Cleaner Clogging	●	
Indicators	●	
ECO Gauges	●	
Fuel Level Gauge	●	
Hyd. Oil Temperature Gauge	●	
Fuel Warmer	●	
Warnings	●	
Communication Error	●	
Low Battery	●	
Clock	●	
Cabin Lights		●
Cabin Front Window Rain Guard		●
Cabin Roof-Steel Cover		●
Seat		
Adjustable Air Suspension Seat With Heater		●
Cabin FOG (ISO 10262) Level 2		
FOG (Falling Object Protective Structure) · ISO 10262 Level 2		●
Cabin ROPS		
ROPS (Roll Over Protective Structures) · ISO 1211 7-2	●	

SAFETY	STD	OPT
Battery Master Switch	●	
Rearview Camera		●
AAVM (Advanced Around View Monitoring)		●
Four Front Working Lights (2 Boom Mounted, 2 Front Frame Mounted)	●	
Travel Alarm	●	
Rear Work Lamp		●
Beacon Lamp		●
Automatic Swing Brake	●	
Boom Holding System	●	
Arm Holding System	●	
Safety Lock Valve For Boom Cylinder With Overload Warning Device		●
Safety Lock Valve For Arm Cylinder		●
Swing Lock System		●
Three Outside Rearview Mirror	●	
Front Guard - Wire Net		●
ATTACHMENT		
Booms		
5.85 m, 19' 2" Mono Boom	●	
5.90 m, 19' 4" 2-Piece Boom		●
Arms		
2.10 m, 6' 11"		●
2.50 m, 8' 2"		●
3.05 m, 10' 0"	●	
3.60 m, 11' 10"		●
OTHER		
Removable Clean-Out Dust Net For Cooler	●	
Removable Reservoir Tank	●	
Fuel Pre-Filter	●	
Fuel Warmer	●	
Self-Diagnostics System	●	
Hi MATE (Remote Management System)		●
Batteries (2 × 12 V × 100 AH)	●	
Fuel Filler Pump (50 lpm)		●
Single-Acting Piping Kit (Breaker, Etc.)		●
Double-Acting Piping Kit (Clamshell, Etc.)		●
2 way Proportional RCV & Pedal control selection		●
Rotating Piping Kit		●
Quick Coupler Piping		●
Quick Coupler		●
One Pedal Straight Travel System		●
Accumulator For Lowering Work Equipment	●	
Pattern Change Valve (2 Patterns)		●
Fine Swing Control System		●
Tool Kit		●
UNDERCARRIAGE		
Lower Frame Under Cover (Additional)		●
Lower Frame Under Cover (Normal)	●	
Track Shoes		
Triple Grousers Shoes (600 mm, 24")	●	
Triple Grousers Shoes (700 mm, 28")		●
Triple Grousers Shoes (800 mm, 32")		●
Triple Grousers Shoes (900 mm, 36")		●
Double grousers Shoes (700 mm, 28")		●
Track Rail Guard	●	

- * Standard and optional equipment may vary. Contact your Hyundai dealer for more information. The machine may vary according to International standards.
- * The photos may include attachments and optional equipment that are not available in your area.
- * Materials and specifications are subject to change without advance notice.
- * All imperial measurements rounded off to the nearest pound or inch.

MEMO

MEMO

MEMO