

HT100v

With EU Stage V / EPA Tier 4 Final Engine installed

* Photo may include optional equipment.



Head Office(Sales Office)
14F, GLOBAL R&D CENTER, 477 BUNDANG SUSEO-RO, BUNDANG-GU, SEONGNAM-SI, GYEONGGI-DO, 13553, KOREA

PLEASE CONTACT

Engine Gross Power
73.6 HP (54.9 kW) / 2,400 rpm

Rated operating capacity (35% of tipping load)
1,043 kg (2,300 lb)

Operating Weight
4,564 kg (10,062 lb)

WHAT'S NEWEST AND BEST

HT100V

THE BEST PRODUCTIVITY

- EU STAGE-V Engine
- Vertical Lift Path
- Auto Self-Leveling System
- Two Speed Travel
- High-Flow Hydraulic System **Option**
- Multifunction Lever

EASY CONTROL AND COMFORTABLE OPERATION

- Excellent Visibility
- Outstanding A/C Performance
- Foot Pedal & Rotary S/W
- Spacious Cabin
- Easy Open/Close Sliding Door
- LED Working Lights
- Ride Control System
- Canopy (ROPS/FOPS) **Option**

THE ULTIMATE SAFE ENVIRONMENT

- Rear View Camera
- Escort System
- Emergency Boom Down
- Emergency Escape
- Control Interlock System
- Main Disconnect S/W

RELIABILITY AND VERSATILITY

- Air Intake For Engine
- Dual Air-Cleaner Elements
- Robust Rear Door
- Hydraulic Quick Attachment
- 14 Pin Elec. Connector

SERVICEABILITY AND TELEMATICS

- Hi MATE
- Fully Openable Rear Door
- Easy Battery Replacement
- Fully Openable Tilt-up Cabin





THE BEST PRODUCTIVITY

The newly launched HYUNDAI compact track loader HT100V is satisfying the most strict environmental emission regulations in the world and the SSL/CTL series have a number of new features that contribute to overall fuel and production efficiency.



* Photo may include optional equipment.

HIGH-FLOW HYDRAULIC SYSTEM Option

The high flow function is a necessary option to use attachments that require high hydraulic flow. This option increases the auxiliary hydraulic flow rate from 82.9lpm(21.9gpm) to 128.8lpm(34gpm). The coupler manifold includes both 1/2" and 3/4" couplers.



MULTIFUNCTION LEVER

The ergonomically designed joysticks allow the operator to control all major machine functions with their hands only. It greatly reduced the fatigue of the operator when control machine and attachment.

▶ Right Control lever (Boom&Bucket) Lever button operation



1. AUX electric mode activation button
2. AUX port : Male coupler port
3. 14-pin power supply-E
4. 14-pin power supply-F
5. AUX port : Female coupler port
6. AUX jog dial

▶ Left Control lever(Driving) Lever button operation



1. 14-pin power supply-G
2. 14-pin power supply-H
3. Ride Control
4. Horn button
5. 14-pin power supply-C
6. 14-pin power supply-D
7. 2-speed button



▶ EU STAGE-V Engine

'Hyundai 4HT15 / 4HT14' engine meeting Euro STAGE-V / EPA Tier 4 Final emission regulations are designed for the best productivity. The engine provides enough power for jobs of all types with either a bucket or special attachment.

▶ Vertical Lift Path

The vertical lift path is the load was being lifted vertically. The geometry of the arm allows the boom to raise the bucket straight up to full height. The vertical lift path has better stability, greater lift height, and better operating capacity than the radial lift path.



▶ Auto Self-Leveling System

The auto self-leveling system keeps the bucket or fork level without the need to manually adjust the angle on the way up during lifting and this feature can be engaged with the flip of a switch.

▶ Two Speed Travel

This function provides two travel speeds for standard, so the speed can be selected according to the needs of the site and the operator's preference. This feature helps save time by moving faster and completing jobs quickly.

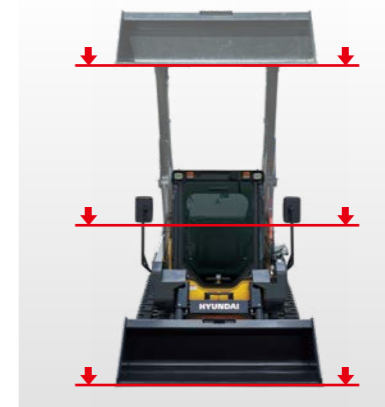

▶ Excellent Visibility

The wide front window gives the operator an excellent view of buckets or attachments. The visibility of window on the roof of the cabin also provides the operator a clear view when raising a load above the cabin.



▶ Outstanding A/C Performance

Optimized airflow through five vents provides outstanding cooling and heating throughout the year. It also prevents fog or frost on the windows in cold weather, so as not to interfere with the work.

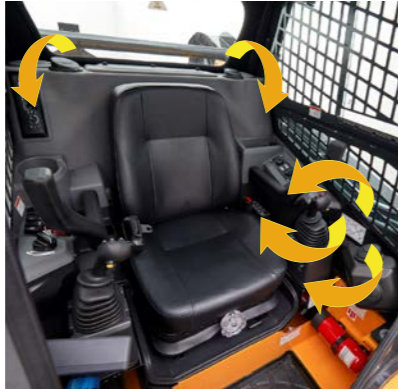

▶ Foot Pedal & Rotary S/W

Engine speed can be controlled by the rotary s/w and the foot pedal during operation. The rotary s/w is suitable for tasks that required constant engine speed. The foot pedal is suitable for tasks that required RPM change.



▶ Ride Control System

Ride control system reduces operator fatigue and material spillage during operation. An accumulator helps to minimize shock, giving the operator a much smoother ride.

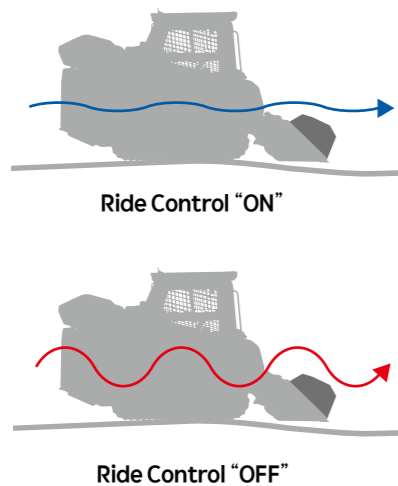

SPACIOUS CABIN

This cabin provides a wide indoor space. It minimizes fatigue even for work long time.



EASY OPEN/CLOSE SLIDING DOOR

The sliding front door can be easily opened and closed without any effort. And the loader can operate regard -less of whether the door is opened or closed. You can work with the front door open.



LED WORKING LIGHTS

Bright and long-lasting LED lights are applied to the front side(2EA) and rear side(2EA) of the cabin for standard.



EASY CONTROL AND COMFORTABLE OPERATION

Many convenience functions are concentrated in the most convenient spot for operators to improve work efficiency. And easy control functions provide both productivity and comfort to operators while working. SSL/CTL series is designed with the operator in mind.



*Photo may include optional equipment.

THE ULTIMATE SAFE ENVIRONMENT

With the top priority on satisfaction of operators in terms of silence, safety and maintainability, Hyundai compact track loader provides operators with comfortable cabin space by low-vibration, low-noise and superior safety design.



*Photo may include optional equipment.

➤ Rear View Camera

The rear camera provides the operator with a rear view when traveling or working. The camera screen is displayed on the cluster and automatically changed to the camera screen when traveling backward.



➤ Escort System

When the engine is turned off, the working lights of the front and rear are turned on for 30 seconds at the night. It has set up an environment where operators can get off safely at night.



➤ Emergency Boom Down

If the boom fails to descend due to a failure of the electrical system, it can manually descend through the boom down button at the bottom of the operator's seat.



➤ Emergency Escape

In an emergency, if an operator inside the cabin is unable to escape through the front door, it can escape through the rear window.

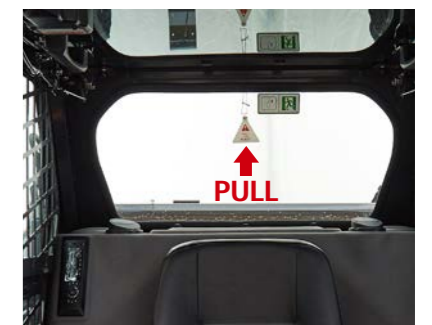

➤ Control Interlock System

Traveling and working devices can only be operated with all seat bars lowered to prevent accidents in unintended situations, such as accidentally touching joysticks.



➤ Main Disconnect S/W

The main disconnect switch prevents battery discharge during long-term storage. After power is cut off, theft prevention and unintended operating may be prevented through a switch knob separation.



RELIABILITY AND VERSATILITY

The true value of the HT100V is revealed in tough working environments. With the high-strength design structure and enduring system proven by rigorous road tests and a variety of attachment tests at various work sites, Hyundai compact track loader can perform any high-load work and any jobsite to maximize productivity.



AIR INTAKE FOR ENGINE

The upper protection cover blocks the inflow of rainwater and dust to prevent contamination and corrosion of a condenser and parts inside the engine room,



DUAL AIR-CLEANER ELEMENTS

The dual air-cleaner elements are applied to the engine filter. This can filter out dust from the air and supply only fresh air to the engine.



MAIN FRAME AND UNDERCARRIAGE

Undercarriage is fully welded to the main frame for the ultimate durability.



WIDE RUBBER TRACK

400mm wide rubber track is applied as standard. This feature has high stability due to wide contact area and is easy to work on soft ground.



ATTACHMENT



Bucket



Sweeper



Pallet Fork

Hydraulic Quick Attachment

Operator can change the attachment quickly by operating the hydraulic cylinder with a button without leaving the seat and worrying about injury. An hydraulic attachment coupler increases uptime and productivity on the jobsite by allowing operators to exchange attachments quickly and safely.



14 Pin Elec. Connector

The 14 pins electrical connector is applied to control various attachments.

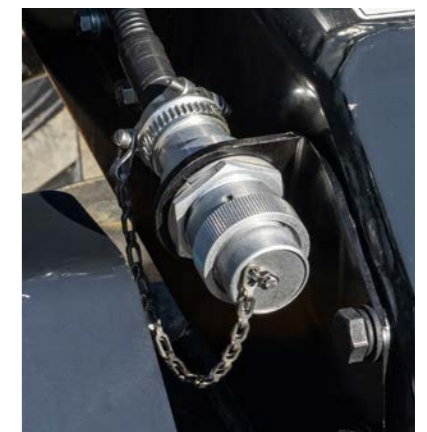

*Photo may include optional equipment.

SERVICEABILITY AND TELEMATICS

IoT, ICT, AI-based digital technologies is creating smart construction sites. Maximizes connectivity, productivity, and safety for your successful businesses.



Hi MATE

IT'S CONVENIENT, EASY AND VALUABLE

Hi MATE Hyundai's newly developed remote management system, utilizes GPS-satellite technology to provide customers with the highest level of service and product support available. Hi MATE enables users to remotely evaluate machine performance, access diagnostic information, and verify machine locations at the touch of a button.

WHAT IS BENEFITS



Increase Productivity

It helps you operate machines in efficient. You can check the difference between total engine hours and actual working hours. See how productive your machines are and plan any required cost saving solutions. Hi MATE offers working information such as working / idling hours, fuel consumption and rate.



Convenient and Easy Monitoring

There is nothing much to do to monitor your machines. Just log on to the Hi MATE website or mobile application. Hi MATE allows you to watch your machines whenever and wherever you are.



Security

Protect your machines from theft or unauthorized usage with Hi MATE. If the machine moves out of the Geo-fence boundary, you will get alerts.

Fully Openable Rear Door

The rear door can be opened easily. And the radiator module is applied swing out type. It provides easy access to the engine compartments, hydraulic filter, ECU and etc.



Easy Battery Replacement

With easy battery replacement, the machine can be managed more easily.



Fully Openable Tilt-up Cabin

Tilt-up cabin can be fully opened without having to lift the arm, allowing easy access and maintenance.



HT100V SPECIFICATIONS

ENGINE	
Maker	Hyundai
Model	4HT14 / 4HT15
Emission Certification	EPA Tier4-Final / EU Stage-V
Type	water cooled, 4-cycle, turbocharged, electronic controlled, diesel engine
Gross Power (SAE J1995)	73.6 hp (54.9kW) / 2,400 rpm
Net Power (SAE J1349)	69.7 hp (52kW) / 2,400 rpm
Max. Power	73.6 hp (54.9kW) / 2,400 rpm
Peak Gross Torque	274 N·m (202 lbf·ft) / 1,500rpm
Displacement	2,435 cc (148.6 cu in)
Number of cylinders	4 cylinders
Bore	87 mm (3.4")
Stroke	102.4 mm (4")

OPERATING SPECIFICATION	
Operating Weight	4,564 kg (10,062 lb)
Breakout force (Bucket)	2,500 kgf (5,512 lbf)
Breakout force (Lift arm)	2,275 kgf (5,016 lbf)
Traction force	2,940 kgf (6,482 lbf)
Lift Arm Path	Vertical
Control	ISO Pilot

RATED OPERATING CAPACITY	
50% Tipping Load	1,043 kg (2,300 lb)
Tipping Load	2,980 kg (6,570 lb)

BUCKET CAPACITY	
Heaped	0.44 m ³ (0.58 yd ³)
Struck	0.33 m ³ (0.43 yd ³)

CABIN	
ROPS	ISO 3471
FOPS	ISO 3449

UNDERCARRIAGE	
Track width	400 mm (1' 4")
Ground pressure	39.8 kPa (5.6 psi)
No. of track roller (per side)	4
Track ground contact area	0.574 m ² (0.686 yd ²)
Travel Speed(2-Speed) Low	7.5 km/h (4.7 mph)
Travel Speed(2-Speed) High	11.5 km/h (7.1 mph)
Track Tension Type	Grease

HYDRAULIC SYSTEM	
HYDRAULIC FLOW - BASIC	
Hydraulic Pressure	230 bar (3,335 psi)
Hydraulic Flow	82.9 lpm (21.9 gpm)
HYDRAULIC FLOW - HIGH FLOW	
Hydraulic Pressure	150 bar (2,176 psi)
Hydraulic Flow	128.8 lpm (34 gpm)

CAPACITY	
Fuel Tank	100 liters (26.4 US gal)
Engine oil (Filter included)	9 liters (2.4 US gal)
Engine coolant (Only Engine)	4.2 liters (1.1 US gal)
Engine coolant (Radiator Included)	10.4 liters (2.7 US gal)
Hydraulic tank	38 liters (10 US gal)

SOUND	
Inside Cab (ISO 6396:2008)	83 dB
Outside Cab (EU Directive 2000/14/EC)	103 dB

OPTION EQUIPMENT	
<ul style="list-style-type: none"> High Flow Hydraulic System* (1/2" and 3/4" Couplers) 2" Retractable Seat Belt* Side Mirror License Lamp Beacon Lamp Driving Lamp (Front 2/Rear 2) Mechanical Quick Coupler* Additional Counterweight 	<ul style="list-style-type: none"> Canopy (ROPS/FOPS)* Mech. Suspension Seat (EU Cert)* Polycarbonate Front Door* Fire Extinguisher Tool Kit Wide Bucket Wide Bucket with BOCE ... and much more.

* Factory Option

DIMENSIONS & SPECIFICATIONS

DIMENSIONS

All dimensions are approximate.

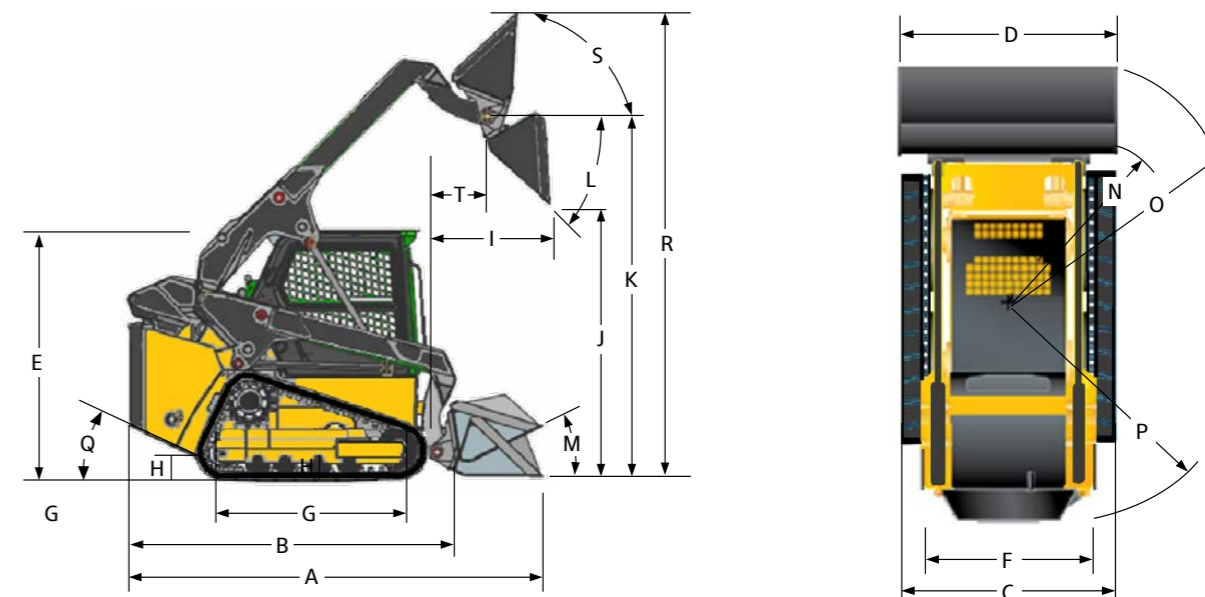

Unit : mm (ft - in)

DIMENSIONS		HT100V
A	Length w/bucket on ground	3,675 (12' 7")
B	Length w/o bucket	2,950 (9' 8")
C	Vehicle width	1,800 (5' 11")
D	Width with bucket	1,890 (6' 3")
E	Height to top of cab	2,080 (6' 10")
F	Track tread	1,400 (4' 7")
G	Length of track on ground	1,435 (4' 8")
H	Ground clearance	220 (0' 9")
I	Reach at max. lift and dump	1,098 (3' 7")
J	Height at max. lift and dump	2,585 (8' 6")
K	Hinge pin height at max. lift	3,310 (10' 10")
L	Max. dump angle	42°
M	Rollback angle on ground	27°
N	Turning radius from Center - Coupler	1,450 (4' 9")
O	Turning radius from Center - Bucket	2,223 (7' 4")
P	Turning radius from Center - Machine Rear	1,709 (5' 7")
Q	Rear departure angle	25°
R	Max. Overall Height	4,160 (13' 8")
S	Rack Back Angle at max height	88°
T	Bucket Pin Reach at Maximum Lift	597 (1' 12")

EQUIPMENT

STANDARD EQUIPMENT	
<ul style="list-style-type: none"> Closed Cabin (ROPS/FOPS) Mechanical Suspension Seat 3" Retractable Seat Belt 12V Electric Outlet / USB Outlet Air Conditioner & Heater Horn / Backup Alarm Driving Lamp (Rear 2) Working Lamp (Front 2/Rear 2) Stop Lamp Dial and Foot Throttle Hydraulic Quick Coupler Rubber Wide Track 15.7"(400mm) 	<ul style="list-style-type: none"> Boom Float Function Dual Air-Cleaner Elements Rear View Camera Bucket Self Leveling (Up only) Rear View Mirror Two-Speed Travel Multifunction Lever Ride Control System Bluetooth/USB Radio Telematics (Hi Mate) 14 pin coupler for attachments