

# STANDARD / OPTION

ENGINE	STD	OPT
Hyundai HE8.9	●	
HYDRAULIC SYSTEM	STD	OPT
Intelligent Power Control (IPC)		
3-power mode, 2-work mode, user mode	●	
Variable power control	●	
Pump flow control	●	
Attachment mode flow control		●
Engine auto idle	●	
Engine auto shutdown control		●
CAB & INTERIOR	STD	OPT
ISO Standard Cabin		
All-weather steel cab with 360° visibility	●	
Safety glass windows	●	
Rise-up type windshield wiper	●	
Sliding side window(LH)	●	
Lockable door	●	
Hot & cool box	●	
Storage compartment & Ashtray	●	
Radio / USB Player	●	
12 volt power outlet (24V DC to 12V DC converter)	●	
Handsfree mobile phone system with USB	●	
Sun visor	●	
Door and cab locks, one key	●	
Pilot-operated slidable joystick	●	
Cabin lights		●
Cabin front window rain guard		●
Transparent cabin roof-cover	●	
Cabin roof-steel cover		●
Automatic Climate Control		
Air conditioner & Heater	●	
Defroster	●	
Starting aid (air grid heater) for cold weather	●	
Centralized Monitoring		
8" LCD display - Normal type	●	
8" LCD display - Premium type		●
Engine speed or trip meter / Accel	●	
Engine coolant temperature gauge	●	
Max power	●	
Low speed / High speed	●	
Auto idle	●	
Overload Warning Alarm		●
Air cleaner clogging	●	
Indicators	●	
ECO gauges	●	
Fuel level gauge	●	
Hyd. oil temperature gauge	●	
Warnings	●	
Communication error	●	
Low battery	●	
Clock	●	
Seat		
Mechanical suspension without heater		●
Mechanical suspension with heater	●	
Adjustable air suspension without heater		●
Adjustable air suspension with heater		●
Cabin FOPS/FOG (ISO/DIS 10262 Level II)		
FOPS (Falling object protective structures) · ISO 10262 Level 2		●
Cabin ROPS (ISO 12117-2)		
ROPS (Roll over protective structures) · ISO 12117-2		●

SAFETY	STD	OPT
Battery master switch	●	
Rearview camera		●
AAVM (Advanced around view monitoring)		●
Front working lights	●	
Travel alarm	●	
Rear work lamp		●
Beacon lamp		●
Automatic swing brake	●	
Boom holding system	●	
Arm holding system	●	
Safety lock valve for boom cylinder with overload warning device		●
Safety lock valve for arm cylinder		●
Swing Lock system		●
Outside rear view mirror	●	
ATTACHMENT	STD	OPT
Booms		
6.15 m		●
6.5 m Heavy Duty	●	
Arms		
2.8 m		●
2.55 m		●
3.9 m		●
3.2 m Heavy Duty	●	
OTHERS	STD	OPT
Removable clean-out dust net for cooler	●	
Removable washer tank	●	
Fuel pre-filter	●	
Fuel warmer		●
Fuel warmer-Dual		●
Self-diagnostics system	●	
Hi MATE (Remote management system)		●
Batteries (2 × 12 V × 200 AH)	●	
Fuel filler pump (50 l/min)		●
Single-acting piping kit (Breaker, etc.)		●
Double-acting piping kit (Clamshell, etc.)		●
Quick coupler piping		●
Quick coupler		●
Accumulator for lowering work equipment	●	
2 Pattern		●
Fine swing control system		●
General type guardrail		●
Tool kit		●
Rain cap	●	
Pre-cleaner		●
UNDERCARRIAGE	STD	OPT
Lower frame under cover (Additional)		●
Lower frame under cover (Normal)	●	
Lower frame (Long Crawler)	●	
Lower frame (Narrow)		●
Track Shoes		
Triple grousers shoes 600 mm (24")	●	
Triple grousers shoe 700 mm (28")		●
Triple grousers shoe 800 mm (32")		●
Triple grousers shoe 900 mm (36")		●
Track rail guard	●	
Full track rail guard		●

\* Standard and optional equipment may vary. Contact your hyundai dealer for more information.  
 The machine may vary according to international standards.  
 \* The photos may include attachments and optional equipment that are not available in your area.  
 \* Materials and specifications are subject to change without advance notice.  
 \* All imperial measurements rounded off to the nearest pound or inch.

# HX400 L

With Tier 3 Engine installed

\* Photo may include optional equipment.



**Gross Power**  
209 kW (280 hp) at 2,000 rpm

**Net Power**  
205 kW (275 hp) at 2,000 rpm

**Bucket Capacity**  
1.46 ~ 2.50 m<sup>3</sup>

**Operating Weight**  
38,420 kg

# RULE THE GROUND

**HX400L**

The HX-LT3 Series exceeds customer's expectation!  
Become a true leader on the ground with HCE's HX-LT3 Series.

## WORK MAX, WORTH MAX

- IPC (Intelligent Power Control) **Upgrade**
- Attachment Flow Control **Option**
- New Cooling System with Increased Air Flow
- Fuel Rate Information
- ECO Gauge
- Enlarged Air Inlet with Grill Cover

## MORE RELIABLE, MORE SUSTAINABLE

- Durable Cooling Module
- Reinforced Pin, Bush, and Polymer Shim
- Reinforced Durability of Upper and Lower Structure and Attachments
- Wear Resistant Cover Plate
- Hi-grade (High-pressure) Hoses

## INFOTAINMENT FRONTIER

- Proportional Auxiliary Hydraulic System **Option**
- Quick Coupler Button **Option**
- New Front Side Air Conditioning Systems
- Intelligent and Wide Cluster
- New Air Conditioning System
- Audio System

## MODERN COMFORT, SIMPLE AND SAFE SOLUTION

- AAVM (Advanced Around View Monitoring) Camera System **Option**
- Hi MATE (Remote Management System) **Option**
- Swing Lock System **Option**
- Fine Swing Control **Option**
- Cab Suspension Mount



\*Photo may include optional equipment.

15% increased greater screen from 7 to 8 inch is applied in HX-LT3 Series. More functions and better resolution are available with adding premium options.

### IPC (Intelligent Power Control)

Upgrade

HX-LT3 Series adopts the upgraded IPC system. It is able to optimize pump flow rate and power at the various working condition through the individual pump control. Furthermore, optimized design of MCV and pipe line minimizes energy loss such as conflux and throttle loss.



### Attachment Flow Control Option

HX-LT3 Series improves pump flow rate by independent control of two pumps. It optimizes attachments for effective flow rate setting depending on attachments (ten breaker types and ten crusher types), enabling various operations matching the site environments.



### Eco Gauge

Eco gauge enables economic operation of machines. The gauge level and color displays engine torque and fuel efficiency level. On top of that, the status of fuel consumption such as average rate and the total amount of fuel consumed is displayed. Hourly and daily based fuel consumption can be checked in the detailed menu as well.



### Fuel Rate Information



### New Cooling System with Increased Air Flow

With side by side type cooling module improving air inflow, HX-LT3 Series provides excellent cooling performance by increasing heat dissipation and can be easily cleaned.



### Enlarged Air Inlet with Grill Cover

Enlarged vent hole of the air inlet side cover and fine net grill to prevent penetration of foreign materials further improve durability.



### BETTER FUEL-EFFICIENCY (Compared to 9 Series)

Truck Loading

10% ↑  
Leveling

15% ↑  
Daily Fuel Efficiency

12% ↑



# WORK MAX, WORTH MAX

### Fuel Efficient System Allows Great Performance

HX-LT3 Series has an eco-friendly, high-performance engine which ensures both excellent fuel efficiency and high power. With outstanding operating performance proven by rigorous tests at various work sites, it will satisfy any customer's needs.

### New Variable Power Control

HX-LT3 Series minimizes equipment input and output control signals to improve fuel efficiency. Its three-stage power mode ensures the highest performance in any operating environment.



\* P(power) mode : Maximizes speed and power of the equipment for heavy load work.



\* S(standard) mode : Optimizes performance and fuel efficiency of the equipment for general load work.



\* E(economy) mode : Improves the control system for light load work.





# MORE RELIABLE, MORE SUSTAINABLE

## New Exterior Design for Robustness and Safety

The true value of HX-LT3 Series lies in its durability. The robust frame structure and the attachments show the real value of HX-LT3 Series in tough working environments and promise higher productivity.



We make the best performance in rough working conditions without any unsureness with trustworthy HX400L.



## Durable Cooling Module

HX-LT3 Series has a durable cooling module that passed stringent tests, demonstrating the highest productivity in tough working environments.

## Reinforced Durability of Upper and Lower Structure and Attachments

The upper and lower structure and attachments of HX-LT3 Series have higher durability than demanded on the site, as proven through numerous tests including road tests and virtual simulation. The wear resistance of the bucket has been improved by use of new material.



## Reinforced Pins, Bushing, and Polymer Shims

HX-LT3 Series improves lubricity of connecting parts between the equipment and attachments. Gaps with attachments are minimized by wear-resistant long-life pins, bushes, and polymer shims, supporting the highest performance with invariable durability.



## Wear Resistant Cover Plate

A wear-resistant cover plate is installed at the end of the arm to minimize abrasion on the connector between the arm and the bucket. Vibration reduction of buckets enables more stable operation even in high-load work.

## Hi-grade (High-pressure) Hoses

HX-LT3 Series uses high-pressure hoses with improved heat and pressure resistance, greatly increasing the durability of the equipment.

13%

CABIN SPACE FOR DRIVERS INCREASED BY (compared to the previous model)

310mm  
340mm



# INFOTAINMENT FRONTIER

## Improved Instrument Panel for Easier Monitoring

Many electronic functions are concentrated in the most convenient spot for operators to improve work efficiency. The highly-advanced infotainment system, a product of HCE's intensive information technology development, enables both productivity and comfort while working! HX-LT3 Series is designed with the operator in mind.

\* Photo may include optional equipment.

## New Front Side Air-conditioning System

The ventilation is designed for both warm and cool air reaching to operator's faces. It could help operators create more neat and enjoyable atmosphere through indoor air circulation.



## Audio System

The radio player with a USB-based MP3 player, an integrated Bluetooth hands-free feature, and a built-in microphone allow for phone calls while at work and in transit. The radio player is conveniently located on the right side of the operator to allow for improved access.



## Quick Coupler Button Option

Easy attachment replacement of equipment is available with quick coupler button.



## Proportional Auxiliary Hydraulic System Option

Proportional control switch with better speed control helps operators to enlarge the operation convenience whenever they do time-consuming work.



## Intelligent and Wide Cluster

The 8" capacitive-type display (like smartphone display) of HX-LT3 Series is delivering excellent legibility. The centralized switches on the display allow convenience of checking temperature outside the cabin.



\* The above image is 'Premium Type'

## New Air Conditioning System

Front side Air Vent holes make operators more convenient and fresh through direct air flow to driver's face, foot and body.





# MODERN COMFORT, SIMPLE AND SAFE SOLUTION

## New Cabin for More Comfort

Low noise, low vibration, and ergonomic design make the cabin space more comfortable and pleasant! With focus on safety and convenience of operators, HX-LT3 Series allows rapid and safe equipment inspection anytime and anywhere, providing an optimal environment for operators to work.



## HiMATE

Option

### IT'S CONVENIENT, EASY AND VALUABLE

Hi MATE Hyundai's newly developed remote management system, utilizes GPS-satellite technology to provide customers with the highest level of service and product support available. Hi MATE enables users to remotely evaluate machine performance, access diagnostic information, and verify machine locations at the touch of a button.

### WHAT IS BENEFITS



#### Increase Productivity

It helps you operate machines in efficient. You can check the difference between total engine hours and actual working hours. See how productive your machines are and plan any required cost saving solutions. Hi MATE offers working information such as working / idling hours, fuel consumption and rate.



#### Convenient and Easy Monitoring

There is nothing much to do to monitor your machines. Just log on to the Hi MATE website or mobile application. Hi MATE allows you to watch your machines whenever and wherever you are.



#### Security

Protect your machines from theft or unauthorized usage with Hi MATE. If the machine moves out of the Geofence boundary, you will get alerts.



**HX400L with advanced technology ensures our safety on a construction site.**



HX-LT3 Series excavators are products of HCE's spirit of initiative, creativity, and strong drive. HCE engineers, who are the best in the industry, have worked tirelessly to offer a zero-defect product. The new HX-LT3 Series reflects customers' needs in the field gleaned by thorough monitoring.

### AAVM(Advanced Around View Monitoring) Camera System **Option**

HX-LT3 Series has a state-of-the-art AAVM video camera system to secure field of vision for operators in all directions, thereby preventing accidents. Operators can easily check the workplace in the front and rear and to the right and left.

- **AAVM**(Advanced Around View Monitoring) : Secure field of vision in all directions by ten views including 3D bird's eye view and 2D/4CH view.
- **IMOD**(Intelligent Moving Object Detection) : Inform when pedestrians or dangerous objects are moving around the machine waiting for work.

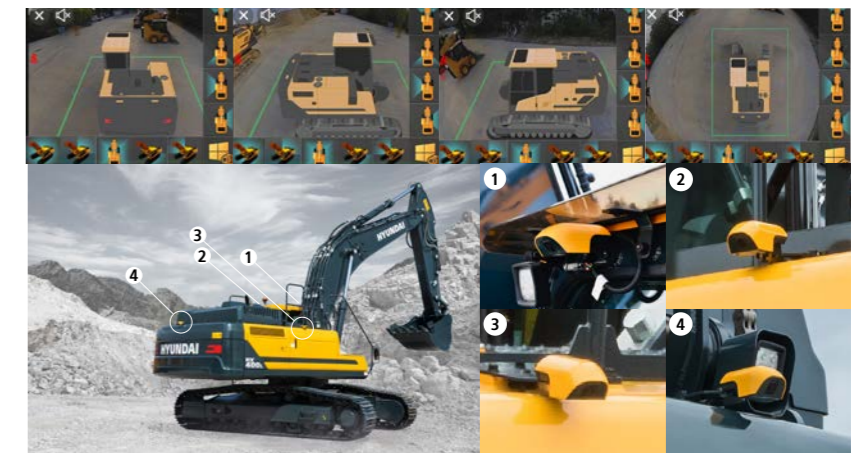

### Swing Lock System **Option**

Swing lock system is provided to maintain stability when swing movement needs to be limited, improving operating speed and productivity.

### Fine Swing Control **Option**

This option enables smooth movement at the start and stop of swing operation(Cushion Swing).

### Cabin Suspension Mount

With a low-vibration design by the coil spring and damper inside the mount, the cab suspension mount of HX-LT3 Series reduces noise inside the cabin and improves durability, providing a comfortable operation space that lessens operators' fatigue.

# SPECIFICATIONS

## ENGINE

Maker / Model	HYUNDAI / HE8.9
Type	6 cylinder, water cooled, 4-cycle, turbocharged charge air cooled, direct injection, electronic controlled diesel engine
Gross Power	209 kW (280 HP) at 2,000 rpm
Net Power	205 kW (275 HP) at 2,000 rpm
Max. Power	231 kW (310 HP) at 1,700 rpm
Peak Torque	1,451 N·m (1,070 lb·ft) at 1,400 rpm
Displacement	8,9 ℓ (543 cu in)

## HYDRAULIC SYSTEM

### MAIN PUMP

Type	Variable displacement piston pump
Max. flow	2×315 ℓ/min
Sub-pump for pilot circuit	Gear pump

Cross-sensing and fuel saving pump system.

### HYDRAULIC MOTORS

Travel	Two speed axial pistons motor with brake valve and parking brake
Swing	Axial piston motor with automatic brake

### RELIEF VALVE SETTING

Implement circuits	350 kgf/cm <sup>2</sup> (4,980 psi)
Travel	350 kgf/cm <sup>2</sup> (4,980 psi)
Swing circuit	290 kgf/cm <sup>2</sup> (4,125 psi)
Pilot circuit	40 kgf/cm <sup>2</sup> (570 psi)
Service valve	Installed

### HYDRAULIC CYLINDERS

No. of cylinder bore X stroke	Boom: 2-160×1,500 mm Arm: 1-170×1,750 mm Bucket: 1-150×1,285 mm
-------------------------------	---

## DRIVES & BRAKES

Drive method	Fully hydrostatic type
Drive motor	Axial piston motor, in-shoe design
Reduction system	Planetary reduction gear
Max. drawbar pull	31,613 kgf
Max. travel speed (high / low)	5.3 km/hr / 3.2 km/hr
Gradeability	35° (70%)
Parking brake	Multi wet disc

## CONTROL

Pilot pressure operated joysticks and pedals with detachable lever provide almost effortless and fatigueless operation.

Pilot control	Two joysticks with one safety lever (LH): Swing and arm, (RH): Boom and bucket (ISO)
Traveling and steering	Two levers with pedals
Engine throttle	Electric, dial type

## SWING SYSTEM

Swing motor	Fixed displacement axial piston motor
Swing reduction	Planetary gear reduction
Swing bearing lubrication	Grease-bathed
Swing brake	Multi wet disc
Swing speed	9.6 rpm

## COOLANT & LUBRICANT CAPACITY

	liter	US gal	UK gal
Fuel tank	600	158.5	132.9
Engine coolant	33	8.7	7.2
Engine oil	30	7.9	6.6
Swing device	7.4	1.96	1.63
Final drive (each)	5.5	1.45	1.21
Hydraulic system (including tank)	414	108.9	91
Hydraulic tank	210	55.3	46.2

## UNDERCARRIAGE

The X-leg type center frame is integrally welded with reinforced box-section track frames. The undercarriage includes lubricated rollers, idlers, track adjusters with shock absorbing springs and sprockets and a track chain with double or triple grouser shoes.

Center frame	X - leg type
Track frame	Pentagonal box type
No. of shoes on each side	51 EA
No. of carrier roller on each side	2 EA
No. of track roller on each side	9 EA
No. of rail guard on each side	2 EA

## OPERATING WEIGHT (APPROXIMATE)

Operating weight, including 6,500 mm (21' 4") boom, 3,200 mm (10' 6") arm, SAE heaped 1.62 m<sup>3</sup> (2.12 yd<sup>3</sup>) bucket, lubricant, coolant, full fuel tank, full hydraulic tank, and all standard equipments.

## OPERATING WEIGHT

Shoes		Operating weight	Ground pressure
Type	Width mm	kg (lb)	kgf/cm <sup>2</sup> (psi)
Triple grouser	600	38,420 (84,700)	0.69 (9.80)
	700	38,870 (85,690)	0.60 (8.49)
	800	39,320 (86,690)	0.53 (7.52)
Double grouser	900	39,780 (87,700)	0.48 (6.77)
	600	38,360 (84,570)	0.69 (9.79)

## AIR CONDITIONING SYSTEM

The air condition system for the machine contains the fluorinated greenhouse gas with global warming potential of R134a. (Global warming potential : 1,430)

The system hold 0.8 kg refrigerant consisting of a CO<sub>2</sub> equivalent 1.14 kg metric tonne. For more information, please refer to the manual.

# DIMENSIONS & WORKING RANGE

## HX400L / HX400N L DIMENSIONS

6.15 m (20' 2"), 6.50 m (21' 4") BOOM and 2.55 m (8' 4"), 2.80 m (9' 2"), 3.20 m (10' 6"), 3.90 m (12' 10") ARM

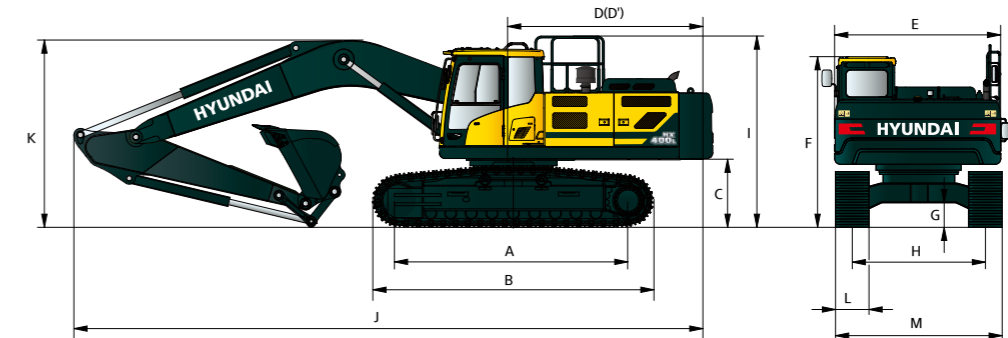

Unit : mm (ft - in)

A Tumbler distance	4,340 (14' 3")	
B Overall length of crawler	5,290 (17' 4")	
C Ground clearance of counterweight	1,295 (4' 3")	
D Tail swing radius	3,620 (11' 11")	
D' Rear-end length	3,555 (11' 8")	
E Overall width of upperstructure	With Catwalk	3,300 (10' 10")
	With Protector	3,110 (10' 2")
F Overall height of cab	3,240 (10' 8")	
G Min. ground clearance	555 (1' 10")	
H Track gauge	HX400L	2,740 (8' 10")
	HX400N L	2,390 (7' 10")
I Overall height of guardrail	3,440 (11' 3")	

		6,150 (20' 2")		6,500 (21' 2")		
Boom length		6,150 (20' 2")		6,500 (21' 2")		
Arm length		2,550 (8' 4")	2,550 (8' 4")	2,800 (9' 2")	3,200 (10' 6")	3,900 (12' 10")
J Overall length		11,070 (36' 4")	11,430 (37' 6")	11,430 (37' 6")	11,410 (37' 5")	11,400 (37' 5")
K Overall height of boom		3,710 (12' 2")	3,670 (12' 0")	3,690 (12' 1")	3,560 (11' 8")	3,690 (12' 1")
L Track shoe width	HX 400L T3	600 (24")	700 (28")	800 (32")	900 (36")	
	HX 400NL T3	600 (24")	-	-	-	
M Overall width	HX 400L T3	3,340 (10' 11")	3,440 (11' 3")	3,540 (11' 7")	3,640 (11' 11")	
	HX 400NL T3	2,990 (9' 10")	-	-	-	

## HX400L / HX400N L WORKING RANGE

Unit : mm (ft - in)

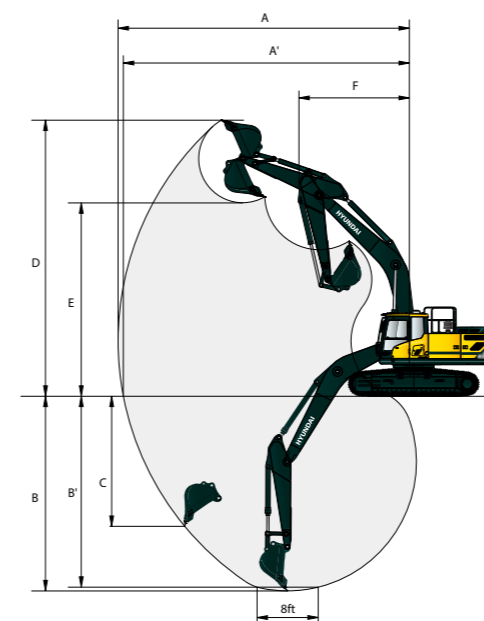

		6,150 (20' 2")		6,500 (21' 4")		
Boom length		6,150 (20' 2")		6,500 (21' 4")		
Arm length		2,550 (8' 4")	2,550 (8' 4")	2,800 (9' 2")	3,200 (10' 6")	3,900 (12' 10")
A Max. digging reach		10,430 (34' 3")	10,800 (35' 5")	11,040 (36' 3")	11,270 (37' 0")	11,920 (39' 1")
A' Max. digging reach on ground		10,190 (33' 5")	10,580 (34' 9")	10,820 (35' 6")	11,050 (36' 3")	11,710 (38' 5")
B Max. digging depth		6,460 (21' 2")	6,710 (22' 0")	6,960 (22' 10")	7,360 (24' 2")	8,060 (26' 5")
B' Max. digging depth (8' level)		6,290 (20' 8")	6,530 (21' 5")	6,780 (22' 3")	7,180 (23' 7")	7,880 (25' 10")
C Max. vertical wall digging depth		4,650 (15' 2")	5,020 (16' 6")	5,230 (17' 2")	4,870 (16' 0")	6,010 (19' 9")
D Max. digging height		10,390 (34' 1")	10,800 (35' 5")	10,940 (35' 11")	10,680 (35' 0")	11,080 (36' 4")
E Max. dumping height		7,100 (23' 4")	7,480 (24' 6")	7,620 (25' 0")	7,480 (24' 6")	7,810 (25' 7")
F Min. swing radius		4,100 (13' 5")	4,250 (13' 11")	4,280 (14' 1")	4,310 (14' 2")	4,070 (13' 4")

# LIFTING CAPACITY

Rating over-front Rating over-side or 360 degree

## HX400L LONG CRAWLER

6.15 m (20' 2") boom, 2.55 m (8' 4") arm equipped with 600 mm (24") triple grouser shoe.

Lift-point height (m/ft)		Lift-point radius								At max. reach		
		3.0 m (9.8 ft)		4.5 m (14.8 ft)		6.0 m (19.7 ft)		7.5 m (24.6 ft)		Capacity		Reach
												m (ft)
7.5 m	kg					*10,350	*10,350			*10,350	8,950	6.77
24.6 ft	lb					*22,820	*22,820			*22,820	19,730	(22.2)
6.0 m	kg					*10,870	10,850	*10,290	7,480	*9,880	7,060	7.74
19.7 ft	lb					*23,960	23,920	*22,690	16,490	*21,780	15,560	(25.4)
4.5 m	kg			*15,550	*15,550	*12,260	10,350	*10,730	7,300	*9,870	6,130	8.32
14.8 ft	lb			*34,280	*34,280	*27,030	22,820	*23,660	16,090	*21,760	13,510	(27.3)
3.0 m	kg			*19,270	14,810	*13,940	9,760	*11,500	7,020	9,350	5,680	8.60
9.8 ft	lb			*42,480	32,650	*30,730	21,520	*25,350	15,480	20,610	12,520	(28.2)
1.5 m	kg			*17,690	14,000	*15,310	9,280	11,340	6,770	9,200	5,550	8.61
4.9 ft	lb			*39,000	30,860	*33,750	20,460	25,000	14,930	20,280	12,240	(28.2)
Ground	kg			*21,680	13,760	15,800	9,020	11,170	6,620	9,560	5,730	8.34
Line	lb			*47,800	30,340	34,830	19,890	24,630	14,590	21,080	12,630	(27.4)
-1.5 m	kg	*14,680	*14,680	*20,660	13,800	*15,560	8,980	11,170	6,620	10,610	6,330	7.78
-4.9 ft	lb	*32,360	*32,360	*45,550	30,420	*34,300	19,800	24,630	14,590	23,390	13,960	(25.5)
-3.0 m	kg	*24,210	*24,210	*18,310	14,070	*13,840	9,150			*11,480	7,700	6.83
-9.8 ft	lb	*53,370	*53,370	*40,370	31,020	*30,510	20,170			*25,310	16,980	(22.4)
-4.5 m	kg			*13,400	*13,400					*10,800	*10,800	5.31
-14.8 ft	lb			*29,540	*29,540					*23,810	*23,810	(17.4)

6.50 m (21' 2") boom, 2.55 m (8' 4") arm equipped with 600 mm (24") triple grouser shoe.

Lift-point height (m/ft)		Lift-point radius								At max. reach				
		3.0 m (9.8 ft)		4.5 m (14.8 ft)		6.0 m (19.7 ft)		7.5 m (24.6 ft)		9.0 m (29.5 ft)		Capacity		Reach
														m (ft)
9.0 m	kg											*10,560	*10,560	5.83
29.5 ft	lb											*23,280	*23,280	(19.1)
7.5 m	kg					*9,940	*9,940					*9,950	7,930	7.25
24.6 ft	lb					*21,910	*21,910					*21,940	17,480	(23.8)
6.0 m	kg					*10,710	*10,710	*9,850	7,440			*9,780	6,400	8.16
19.7 ft	lb					*23,610	*23,610	*21,720	16,400			*21,560	14,110	(26.8)
4.5 m	kg			*16,000	15,740	*12,200	10,160	*10,450	7,200			9,220	5,610	8.71
14.8 ft	lb			*35,270	34,700	*26,900	22,400	*23,040	15,870			20,330	12,370	(28.6)
3.0 m	kg					*13,890	9,520	*11,280	6,890			8,640	5,220	8.98
9.8 ft	lb					*30,620	20,990	*24,870	15,190			19,050	11,510	(29.5)
1.5 m	kg					*15,180	9,040	11,180	6,620			8,510	5,100	8.99
4.9 ft	lb					*33,470	19,930	24,650	14,590			18,760	11,240	(29.5)
Ground	kg			*14,960	13,450	15,550	8,800	11,000	6,460			8,810	5,260	8.73
Line	lb			*32,980	29,650	34,280	19,400	24,250	14,240			19,420	11,600	(28.7)
-1.5 m	kg			*20,160	13,530	*15,340	8,760	10,980	6,440			9,690	5,750	8.20
-4.9 ft	lb			*44,450	29,830	*33,820	19,310	24,210	14,200			21,360	12,680	(26.9)
-3.0 m	kg	*22,990	*22,990	*18,020	13,790	*13,890	8,920					*10,660	6,860	7.31
-9.8 ft	lb	*50,680	*50,680	*39,730	30,400	*30,620	19,670					*23,500	15,120	(24.0)
-4.5 m	kg			*13,990	*13,990							*10,120	9,610	5.92
-14.8 ft	lb			*30,840	*30,840							*22,310	21,190	(19.4)

- Lifting capacity are based on ISO 10567.
- Lifting capacity of HX-LT3 Series does not exceed 75% of tipping load with the machine on firm, level ground or 87% of full hydraulic capacity.
- The Lift-point is bucket pivot mounting pin on the arm(without bucket mass).
- (\*) indicates load limited by hydraulic capacity.

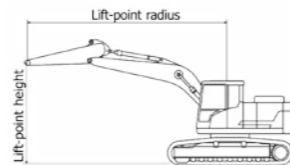

Rating over-front Rating over-side or 360 degree

## HX400L LONG CRAWLER

6.50 m (21' 2") boom, 2.80 m (9' 2") arm equipped with 600 mm (24") triple grouser shoe.

Lift-point height (m/ft)		Lift-point radius								At max. reach				
		3.0 m (9.8 ft)		4.5 m (14.8 ft)		6.0 m (19.7 ft)		7.5 m (24.6 ft)		9.0 m (29.5 ft)		Capacity		Reach
														m (ft)
9.0 m	kg					*9,920	*9,920					*10,030	*10,030	6.18
29.5 ft	lb					*21,870	*21,870					*22,110	*22,110	(20.3)
7.5 m	kg									*9,520	7,560	*9,240	7,470	7.54
24.6 ft	lb									*20,990	16,670	*20,370	16,470	(24.8)
6.0 m	kg					*10,320	*10,320	*9,520	7,500			*8,880	6,100	8.42
19.7 ft	lb					*22,750	*22,750	*20,990	16,530			*19,580	13,450	(27.6)
4.5 m	kg			*15,300	*15,300	*11,830	10,240	*10,190	7,240			8,840	5,380	8.96
14.8 ft	lb			*33,730	*33,730	*26,080	22,580	*22,470	15,960			19,490	11,860	(29.4)
3.0 m	kg					*13,580	9,590	*11,070	6,910	8,630	5,210	8,310	5,010	9.22
9.8 ft	lb					*29,940	21,140	*24,410	15,230	19,030	11,490	18,320	11,050	(30.2)
1.5 m	kg					*14,980	9,080	11,200	6,630	8,490	5,080	8,180	4,900	9.22
4.9 ft	lb					*33,030	20,020	24,690	14,620	18,720	11,200	18,030	10,800	(30.3)
Ground	kg			*15,760	13,420	15,550	8,790	10,990	6,440			8,450	5,040	8.98
Line	lb			*34,740	29,590	34,280	19,380	24,230	14,200			18,630	11,110	(29.4)
-1.5 m	kg	*10,800	*10,800	*20,480	13,460	*15,440	8,720	10,930	6,400			9,220	5,480	8.45
-4.9 ft	lb	*23,810	*23,810	*45,150	29,670	*34,040	19,220	24,100	14,110			20,330	12,080	(27.7)
-3.0 m	kg	*21,330	*21,330	*18,540	13,690	*14,200	8,850	*10,690	6,550			*10,420	6,450	7.60
-9.8 ft	lb	*47,020	*47,020	*40,870	30,180	*31,310	19,510	*23,570	14,440			*22,970	14,220	(24.9)
-4.5 m	kg			*14,890	14,170	*10,950	9,250					*10,090	8,740	6.27
-14.8 ft	lb			*32,830	31,240	*24,140	20,390					*22,240	19,270	(20.6)

6.50 m (21' 2") boom, 3.20 m ( 10' 6" ) arm equipped with 600 mm (24") triple grouser shoe.

Lift-point height (m/ft)		Lift-point radius								At max. reach				
		3.0 m (9.8 ft)		4.5 m (14.8 ft)		6.0 m (19.7 ft)		7.5 m (24.6 ft)		9.0 m (29.5 ft)		Capacity		Reach
														m (ft)
9.0 m	kg											*8,330	*8,330	6.52
29.5 ft	lb											*18,360	*18,360	(21.4)
7.5 m	kg									*8,790	7,710	*7,740	7,130	7.82
24.6 ft	lb									*19,380	17,000	*17,060	15,720	(25.7)
6.0 m	kg					*9,680	*9,680	*9,010	7,590			*7,570	5,870	8.67
19.7 ft	lb					*21,340	*21,340	*19,860	16,730			*16,690	12,940	(28.4)
4.5 m	kg			*14,200	*14,200	*11,230	10,380	*9,750	7,310	8,830	5,390	*7,670	5,190	9.19
14.8 ft	lb			*31,310	*31,310	*24,760	22,880	*21,500	16,120	19,470	11,880	*16,910	11,440	(30.2)
3.0 m	kg			*18,040	14,800	*13,050	9,710	*10,700	6,960	8,660	5,230	8,010	4,830	9.44
9.8 ft	lb			*39,770	32,630	*28,770	21,410	*23,590	15,340	19,090	11,530	17,660	10,650	(31.0)
1.5 m	kg			*18,170	13,780	*14,600	9,140	11,220	6,650	8,480	5,070	7,870	4,710	9.45
4.9 ft	lb			*40,060	30,380	*32,190	20,150	24,740	14,660	18,700	11,180	17,350	10,380	(31.0)
Ground	kg			*19,360	13,400	*15,470	8,790	10,970	6,430	8,370	4,970	8,090	4,810	9.21
Line	lb			*42,680	29,540	*34,110	19,380	24,180	14,180	18,450	10,960	17,840	10,600	(30.2)
-1.5 m	kg	*12,640	*12,640	*20,840	13,360	15,410	8,670	10,870	6,340			8,770	5,190	8.70
-4.9 ft	lb	*27,870	*27,870	*45,940	29,450	33,970	19,110	23,960	13,980			19,330	11,440	(28.5)
-3.0 m	kg	*20,920	*20,920	*19,230	13,530	*14,600	8,740	10,960	6,410			10,230	6,030	7.87
-9.8 ft	lb	*46,120	*46,120	*42,390	29,830	*32,190	19,270	24,160	14,130			22,550	13,290	(25.8)
-4.5 m	kg	*21,490	*21,490	*16,120	13,950	*12,130	9,040					*10,550	7,940	6.60
-14.8 ft	lb	*47,380	*47,380	*35,540	30,750	*26,74								

# LIFTING CAPACITY

Rating over-front Rating over-side or 360 degree

## HX400L LONG CRAWLER

6.50 m (21' 2") boom, 3.90 m (12' 10") arm equipped with 600 mm (24") triple grouser shoe.

Lift-point height (m/ft)		Lift-point radius								At max. reach						
		1.5 m (4.9 ft)		3.0 m (9.8 ft)		4.5 m (14.8 ft)		6.0 m (19.7 ft)		7.5 m (24.6 ft)		9.0 m (29.5 ft)		Capacity		Reach
																m (ft)
9.0 m	kg													*6,170	*6,170	7.44
29.5 ft	lb													*13,600	*13,600	(24.4)
7.5 m	kg									*7,750	*7,750			*5,790	*5,790	8.60
24.6 ft	lb									*17,090	*17,090			*12,760	*12,760	(28.2)
6.0 m	kg									*8,140	7,780	*7,110	5,640	*5,670	5,210	9.38
19.7 ft	lb									*17,950	17,150	*15,670	12,430	*12,500	11,490	(30.8)
4.5 m	kg									*10,130	*10,130			*8,980	7,470	9.86
14.8 ft	lb									*22,330	*22,330	*19,800	16,470	*18,390	12,130	(32.4)
3.0 m	kg									*16,220	15,440	*12,080	9,970	*10,040	7,090	10.10
9.8 ft	lb									*35,760	34,040	*26,630	21,980	*22,130	15,630	(33.1)
1.5 m	kg									*19,460	14,160	*13,870	9,320	*11,070	6,730	10.10
4.9 ft	lb									*42,900	31,220	*30,580	20,550	*24,410	14,840	(33.1)
Ground Line	kg									*20,850	13,500	*15,090	8,870	11,010	6,450	9.88
	lb									*45,970	29,760	*33,270	19,550	24,270	14,220	(32.4)
-1.5 m	kg	*7,910	*7,910	*11,810	*11,810	*21,200	13,280	15,400	8,640	10,840	6,300	8,270	4,880	7,770	4,590	9.41
-4.9 ft	lb	*17,440	*17,440	*26,040	*26,040	*46,740	29,280	33,950	19,050	23,900	13,890	18,230	10,760	17,130	10,120	(30.9)
-3.0 m	kg	*12,870	*12,870	*17,720	*17,720	*20,200	13,340	*15,100	8,620	10,830	6,290			8,810	5,200	8.65
-9.8 ft	lb	*28,370	*28,370	*39,070	*39,070	*44,530	29,410	*33,290	19,000	23,880	13,870			19,420	11,460	(28.4)
-4.5 m	kg			*24,910	*24,910	*17,880	13,640	*13,490	8,800	*10,030	6,480			*9,990	6,470	7.52
-14.8 ft	lb			*54,920	*54,920	*39,420	30,070	*29,740	19,400	*22,110	14,290			*22,020	14,260	(24.7)
-6.0 m	kg					*13,310	*13,310							*9,880	9,810	5.78
-19.7 ft	lb					*29,340	*29,340							*21,780	21,630	(19.0)

## HX400NL NARROW CRAWLER

6.15 m (20' 2") boom, 2.55 m (8' 4") arm equipped with 600 mm (24") triple grouser shoe.

Lift-point height (m/ft)		Lift-point radius				At max. reach						
		3.0 m (9.8 ft)		4.5 m (14.8 ft)		6.0 m (19.7 ft)		7.5 m (24.6 ft)		Capacity		Reach
												m (ft)
7.5 m	kg					*10,350	10,180			*10,350	8,230	6.77
24.6 ft	lb					*22,820	22,440			*22,820	18,140	(22.2)
6.0 m	kg					*10,870	9,940	*10,290	6,880	*9,880	6,500	7.74
19.7 ft	lb					*23,960	21,910	*22,690	15,170	*21,780	14,330	(25.4)
4.5 m	kg									*9,870	5,640	8.32
14.8 ft	lb									*21,760	12,430	(27.3)
3.0 m	kg									*19,270	13,260	8.60
9.8 ft	lb									*42,480	29,230	(28.2)
1.5 m	kg									*17,690	12,490	8.61
4.9 ft	lb									*39,000	27,540	(28.2)
Ground Line	kg									*21,680	12,260	8.34
	lb									*47,800	27,030	(27.4)
-1.5 m	kg	*14,680	*14,680	*20,660	12,310	*15,560	8,140	11,700	6,050	11,120	5,790	7.78
-4.9 ft	lb	*32,360	*32,360	*45,550	27,140	*34,300	17,950	25,790	13,340	24,520	12,760	(25.5)
-3.0 m	kg	*24,210	*24,210	*18,310	12,560	*13,840	8,300			*11,480	7,030	6.83
-9.8 ft	lb	*53,370	*53,370	*40,370	27,690	*30,510	18,300			*25,310	15,500	(22.4)
-4.5 m	kg									*13,400	13,120	5.31
-14.8 ft	lb									*29,540	28,920	(17.4)

- Lifting capacity are based on ISO 10567.
- Lifting capacity of HX-LT3 Series does not exceed 75% of tipping load with the machine on firm, level ground or 87% of full hydraulic capacity.
- The Lift-point is bucket pivot mounting pin on the arm (without bucket mass).
- (\*) indicates load limited by hydraulic capacity.

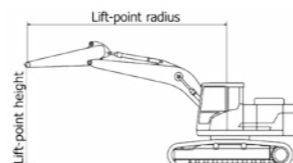

Rating over-front Rating over-side or 360 degree

## HX400NL NARROW CRAWLER

6.50 m (21' 2") boom, 2.55 m (8' 4") arm equipped with 600 mm (24") triple grouser shoe.

Lift-point height (m/ft)		Lift-point radius								At max. reach						
		3.0 m (9.8 ft)		4.5 m (14.8 ft)		6.0 m (19.7 ft)		7.5 m (24.6 ft)		Capacity		Reach				
												m (ft)				
9.0 m	kg															5.83
29.5 ft	lb															(19.1)
7.5 m	kg													*9,940	*9,940	7.25
24.6 ft	lb													*21,910	*21,910	(23.8)
6.0 m	kg													*10,710	9,830	8.16
19.7 ft	lb													*23,610	21,670	(26.8)
4.5 m	kg													*16,000	14,130	8.71
14.8 ft	lb													*35,270	31,150	(28.6)
3.0 m	kg													*13,890	8,660	8.98
9.8 ft	lb													*30,620	19,090	(29.5)
1.5 m	kg													*15,180	8,200	8.99
4.9 ft	lb													*33,470	18,080	(29.5)
Ground Line	kg													*14,960	11,970	8.73
	lb													*32,980	26,390	(28.7)
-1.5 m	kg													*20,160	12,040	8.20
-4.9 ft	lb													*44,450	26,540	(26.9)
-3.0 m	kg	*22,990	*22,990	*18,020	12,290	*13,890	8,080									7.31
-9.8 ft	lb	*50,680	*50,680	*39,730	27,090	*30,620	17,810									(24.0)
-4.5 m	kg															5.92
-14.8 ft	lb															(19.4)

6.50 m (21' 2") boom, 2.80 m (9' 2") arm equipped with 600 mm (24") triple grouser shoe.

Lift-point height (m/ft)		Lift-point radius								At max. reach						
		3.0 m (9.8 ft)		4.5 m (14.8 ft)		6.0 m (19.7 ft)		7.5 m (24.6 ft)		9.0 m (29.5 ft)		Capacity		Reach		
														m (ft)		
9.0 m	kg															6.18
29.5 ft	lb															(20.3)
7.5 m	kg															7.54
24.6 ft	lb															(24.8)
6.0 m	kg															8.42
19.7 ft	lb															(27.6)
4.5 m	kg															8.96
14.8 ft	lb															(29.4)
3.0 m	kg															9.22
9.8 ft	lb															(30.2)
1.5 m	kg															9.22
4.9 ft	lb															(30.3)
Ground Line	kg															8.98
	lb															(29.4)
-1.5 m	kg	*10,800	*10,800	*20,480	11,980	*15,440	7,890	11,460	5,830							8.45
-4.9 ft	lb	*23,810	*23,810	*45,150	26,410	*34,040	17,390	25,260	12,850							(27.7)
-3.0 m	kg	*21,330	*21,330	*18,540	12,190	*14,200	8,010	*10,690	5,980							7.60
-9.8 ft	lb	*47,020	*47,020	*40,870	26,870	*31,310	17,660	*23,570	13,180							(24.9)
-4.5 m	kg															6.27
-14.8 ft	lb															(20.6)

- Lifting capacity are based on ISO 10567.
- Lifting capacity of HX-LT3 Series does not exceed 75% of tipping load with the machine on firm, level ground or 87% of full hydraulic capacity.
- The Lift-point is bucket pivot mounting pin on the arm (without bucket mass).
- (\*) indicates load limited by hydraulic capacity.

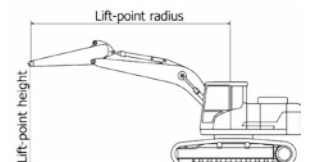

# LIFTING CAPACITY

Rating over-front Rating over-side or 360 degree

## HX400NL NARROW CRAWLER

6.50 m (21' 2") boom, 3.20 m ( 10' 6" ) arm equipped with 600 mm (24") triple grouser shoe.

Lift-point height (m/ft)	Lift-point radius										At max. reach		
	3.0 m (9.8 ft)		4.5 m (14.8 ft)		6.0 m (19.7 ft)		7.5 m (24.6 ft)		9.0 m (29.5 ft)		Capacity		Reach
													m (ft)
9.0 m 29.5 ft	kg										*8,330	*8,330	6.52
	lb										*18,360	*18,360	(21.4)
7.5 m 24.6 ft	kg						*8,790	7,100			*7,740	6,570	7.82
	lb						*19,380	15,650			*17,060	14,480	(25.7)
6.0 m 19.7 ft	kg				*9,680	*9,680	*9,010	6,990			*7,570	5,410	8.67
	lb				*21,340	*21,340	*19,860	15,410			*16,690	11,930	(28.4)
4.5 m 14.8 ft	kg		*14,200	*14,200	*11,230	9,480	*9,750	6,710	*8,980	4,950	*7,670	4,770	9.19
	lb		*31,310	*31,310	*24,760	20,900	*21,500	14,790	*19,800	10,910	*16,910	10,520	(30.2)
3.0 m 9.8 ft	kg		*18,040	13,240	*13,050	8,830	*10,700	6,380	9,070	4,800	*8,020	4,430	9.44
	lb		*39,770	29,190	*28,770	19,470	*23,590	14,070	20,000	10,580	*17,680	9,770	(31.0)
1.5 m 4.9 ft	kg		*18,170	12,280	*14,600	8,280	*11,580	6,070	8,900	4,650	8,260	4,310	9.45
	lb		*40,060	27,070	*32,190	18,250	*25,530	13,380	19,620	10,250	18,210	9,500	(31.0)
Ground Line	kg		*19,360	11,910	*15,470	7,950	11,500	5,860	8,780	4,540	8,490	4,400	9.21
	lb		*42,680	26,260	*34,110	17,530	25,350	12,920	19,360	10,010	18,720	9,700	(30.2)
-1.5 m -4.9 ft	kg	*12,640	*12,640	*20,840	11,870	*15,510	7,830	11,400	5,770		9,200	4,740	8.70
	lb	*27,870	*27,870	*45,940	26,170	*34,190	17,260	25,130	12,720		20,280	10,450	(28.5)
-3.0 m -9.8 ft	kg	*20,920	*20,920	*19,230	12,040	*14,600	7,900	*11,250	5,840		*10,440	5,500	7.87
	lb	*46,120	*46,120	*42,390	26,540	*32,190	17,420	*24,800	12,870		*23,020	12,130	(25.8)
-4.5 m -14.8 ft	kg	*21,490	*21,490	*16,120	12,430	*12,130	8,190				*10,550	7,230	6.60
	lb	*47,380	*47,380	*35,540	27,400	*26,740	18,060				*23,260	15,940	(21.7)

6.50 m (21' 2") boom, 3.90 m ( 12' 10" ) arm equipped with 600 mm (24") triple grouser shoe.

Lift-point height (m/ft)	Lift-point radius										At max. reach					
	1.5 m (4.9 ft)		3.0 m (9.8 ft)		4.5 m (14.8 ft)		6.0 m (19.7 ft)		7.5 m (24.6 ft)		9.0 m (29.5 ft)		Capacity	Reach		
														m (ft)		
9.0 m 29.5 ft	kg												*6,170	*6,170	7.44	
	lb												*13,600	*13,600	(24.4)	
7.5 m 24.6 ft	kg								*7,750	7,330			*5,790	5,680	8.60	
	lb								*17,090	16,160			*12,760	12,520	(28.2)	
6.0 m 19.7 ft	kg								*8,140	7,170	*7,110	5,190	*5,670	4,790	9.38	
	lb								*17,950	15,810	*15,670	11,440	*12,500	10,560	(30.8)	
4.5 m 14.8 ft	kg						*10,130	9,780	*8,980	6,870	*8,340	5,060	*5,740	4,280	9.86	
	lb						*22,330	21,560	*19,800	15,150	*18,390	11,160	*12,650	9,440	(32.4)	
3.0 m 9.8 ft	kg				*16,220	13,840	*12,080	9,090	*10,040	6,500	*8,890	4,870	*5,970	4,000	10.10	
	lb				*35,760	30,510	*26,630	20,040	*22,130	14,330	*19,600	10,740	*13,160	8,820	(33.1)	
1.5 m 4.9 ft	kg				*19,460	12,630	*13,870	8,460	*11,070	6,150	8,940	4,680	*6,390	3,890	10.10	
	lb				*42,900	27,840	*30,580	18,650	*24,410	13,560	19,710	10,320	*14,090	8,580	(33.1)	
Ground Line	kg		*7,130	*7,130	*20,850	12,000	*15,090	8,020	11,540	5,880	8,770	4,520	*7,080	3,940	9.88	
	lb		*15,720	*15,720	*45,970	26,460	*33,270	17,680	25,440	12,960	19,330	9,960	*15,610	8,690	(32.4)	
-1.5 m -4.9 ft	kg	*7,910	*7,910	*11,810	*11,810	*21,200	11,800	*15,530	7,800	11,370	5,730	8,690	4,450	8,160	4,190	9.41
	lb	*17,440	*17,440	*26,040	*26,040	*46,740	26,010	*34,240	17,200	25,070	12,630	19,160	9,810	17,990	9,240	(30.9)
-3.0 m -9.8 ft	kg	*12,870	*12,870	*17,720	*17,720	*20,200	11,860	*15,100	7,780	11,360	5,720			9,250	4,740	8.65
	lb	*28,370	*28,370	*39,070	*39,070	*44,530	26,150	*33,290	17,150	25,040	12,610			20,390	10,450	(28.4)
-4.5 m -14.8 ft	kg		*24,910	24,030	*17,880	12,140	*13,490	7,960	*10,030	5,910				*9,990	5,890	7.52
	lb		*54,920	52,980	*39,420	26,760	*29,740	17,550	*22,110	13,030				*22,020	12,990	(24.7)
-6.0 m -19.7 ft	kg				*13,310	12,720								*9,880	8,890	5.78
	lb				*29,340	28,040								*21,780	19,600	(19.0)

- Lifting capacity are based on ISO 10567.
- Lifting capacity of HX-LT3 Series does not exceed 75% of tipping load with the machine on firm, level ground or 87% of full hydraulic capacity.
- The Lift-point is bucket pivot mounting pin on the arm (without bucket mass).
- (\*) indicates load limited by hydraulic capacity.

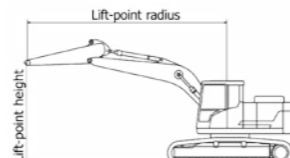

# BUCKET SELECTION GUIDE & DIGGING FORCE

## BUCKETS

SAE heaped  
m<sup>3</sup> (yd<sup>3</sup>)



GP  
1.46  
1.62  
1.90  
2.10  
2.32



HD  
1.46  
1.62  
1.90  
2.10  
2.50



Rock-HD  
1.46  
1.62  
1.90  
2.10

Capacity m <sup>3</sup> (yd <sup>3</sup> )	Width mm (in)	Weight kg (lb)	Tooth (EA)	Recommendation mm (ft.in)					
				6,150 (20' 2") Boom		6,500 (21' 4") Boom			
				2,550 (8' 4") Arm	2,550 (8' 4") Arm	2,800 (9' 2") Arm	3,200 (10' 6") Arm	3,900 (12' 10") Arm	
⊙ 1.46 (1.91)	1.28 (1.67)	1,305 (51.4")	1,400 (3,090)	4	●	●	●	●	●
⊙ 1.62 (2.12)	1.42 (1.86)	1,415 (55.7")	1,500 (3,310)	5	●	●	●	●	■
⊙ 1.90 (2.49)	1.65 (2.16)	1,600 (63.0")	1,610 (3,550)	5	●	●	●	■	▲
⊙ 2.10 (2.75)	1.84 (2.41)	1,735 (68.3")	1,690 (3,730)	5	●	■	■	■	▲
⊙ 2.32 (3.03)	2.02 (2.64)	1,885 (74.2")	1,800 (3,970)	6	■	■	▲	▲	x
◆ 1.46 (1.91)	1.28 (1.67)	1,305 (51.4")	1,560 (3,440)	4	●	●	●	●	●
◆ 1.62 (2.12)	1.42 (1.86)	1,415 (55.7")	1,660 (3,660)	5	●	●	●	●	■
◆ 1.90 (2.49)	1.65 (2.16)	1,600 (63.0")	1,790 (3,950)	5	●	●	■	■	▲
◆ 2.10 (2.75)	1.84 (2.41)	1,735 (68.3")	1,880 (4,140)	5	●	■	■	■	▲
◆ 2.50 (3.27)	2.22 (2.90)	1,750 (68.9")	2,020 (4,450)	5	■	▲	▲	▲	x
◆ 1.46 (1.91)	1.28 (1.67)	1,305 (51.4")	1,750 (3,860)	4	●	●	●	●	x
◆ 1.62 (2.12)	1.42 (1.86)	1,415 (55.7")	1,850 (4,080)	5	●	●	●	●	x
◆ 1.90 (2.49)	1.65 (2.16)	1,600 (63.0")	1,990 (4,390)	5	●	●	■	■	x
◆ 2.10 (2.75)	1.84 (2.41)	1,735 (68.3")	2,090 (4,610)	5	●	■	■	▲	x

- ⊙ General Purpose
- ◆ Heavy duty bucket
- ◆ Rock-HD bucket

- : Applicable for materials with density of 2,100 kgf/m<sup>3</sup> (3,500 lbf/yd<sup>3</sup>) or less
- : Applicable for materials with density of 1,800 kgf/m<sup>3</sup> (3,000 lbf/yd<sup>3</sup>) or less
- : Applicable for materials with density of 1,500 kgf/m<sup>3</sup> (2,500 lbf/yd<sup>3</sup>) or less
- ▲ : Applicable for materials with density of 1,200 kgf/m<sup>3</sup> (2,000 lbf/yd<sup>3</sup>) or less
- x : Not Recommended

## ATTACHMENT

Booms and arms are of all-welded, low-stress, full-box section design. 6,150 mm (20' 2"), 6,500 mm (21' 4") boom and 2,550 mm (8' 4"), 2,800 mm (9' 2"), 3,200 mm (10' 6"), 3,900 mm (12' 10") arms are available, Hyundai Bucket are all-welded, high-strength steel implements.

## DIGGING FORCE

Boom	Length	mm (ft.in)	6,150 (20' 2")		6,500 (21' 4")		Remarks
	Weight	kg (lb)	3,620 (7,980)		3,750 (8,270)		
Arm	Length	mm (ft.in)	2,550 (8' 4")	2,800 (9' 2")	3,200 (10' 6")	3,900 (12' 10")	
	Weight	kg (lb)	1,950 (4,300)	2,000 (4,410)	2,080 (4,590)	2,190 (4,830)	
Bucket Digging Force	SAE	kN	211.8	211.8	211.8	211.8	
		kgf	21,600	21,600	21,600	21,600	
		lbf	47,620	47,620	47,620	47,620	
	ISO	kN	242.2	242.2	242.2	242.2	
		kgf	24,700	24,700	24,700	24,700	
		lbf	54,450	54,450	54,450	54,450	
Arm Crowd Force	SAE	kN	197.1	186.3	170.6	146.1	
		kgf	20,100	19,000	17,400	14,900	
		lbf	44,310	41,890	38,360	32,850	
	ISO	kN	205.0	193.2	176.5	150.0	
		kgf	20,900	19,700	18,000	15,300	
		lbf	46,080	43,430	39,680	33,730	

Note : Boom weight includes arm cylinder, piping, and pin  
Arm weight includes bucket cylinder, linkage, and pin