

### STANDARD EQUIPMENT

#### ISO standard cabin

- Cabin ROPS(ISO 12117-2)  
FOPS (ISO 10262 Level I)  
TOPS (ISO 12117)
- All-weather steel cab with all-around visibility
- Safety glass windows
- Rise-up type windshield wiper
- Sliding fold-in front window
- Sliding side window
- Lockable door
- Accessory box & Ash-tray

#### Centralized monitoring

- Engine speed
- Gauges  
Fuel level gauge

- Engine coolant temperature gauge
- Warning  
Fuel level  
Engine oil pressure  
Engine coolant temperature  
Hyd. oil temperature  
Low battery  
Air cleaner closing
- Fuel prefilter

#### Air-conditioner & heater

- Single acting piping kit (breaker, etc)
- Door and cab locks, one key
- Radio / USB player with remote control
- Outside rear view mirror
- Fully adjustable suspension seat with seat belt

#### Console box tilting system(LH.)

- Three front working lights
- Electric horn
- Battery (1 x 12 V x 100 AH)
- Battery master switch
- 12 volt power supply
- Automatic swing brake
- Removable reservoir tank
- Water separator, fuel line
- Mono boom (3.4 m, 11' 2")
- Arm (1.67 m, 5' 6")
- Track shoes (450 mm, 1' 6")
- Track rail guard
- Starting aid (air grid heater) cold weather

### OPTIONAL EQUIPMENT

#### Fuel filler pump (35ℓ /min, 9.2 US gpm)

- Beacon lamp
- Double acting piping kit (clamshell, etc)
- Accumulator, work equipment lowering
- Electric transducer
- Travel alarm

#### Quick coupler

- Rubber crawler (400mm, 16")
- Track shoes (600mm, 1' 12")
- Long arm (2.2m, 7' 3")
- Tool kit
- Operator suit

#### Mechanical suspension seat with heater

- Cabin rear work lamp
- Lever pattern change valve
- Track shoes (600mm, 1' 12")
- Additional CWT (400kg, 880lb)

\* Standard and optional equipment may vary. Contact your Hyundai dealer for more information. The machine may vary according to International standards.

\* The photos may include attachments and optional equipment that are not available in your area.

\* Materials and specifications are subject to change without advance notice.

\* All imperial measurements rounded off to the nearest pound or inch.



Head Office(Sales Office)  
14F, GLOBAL R&D CENTER, 477 BUNDANG SUSEO-RO, BUNDANG-GU, SEONGNAM-SI, GYEONGGI-DO, 13553, KOREA

# Robex 80CR-9

With Tier 4 Interim Engine Installed

\* Photo may include optional equipment.



PLEASE CONTACT

# Pride at Work

Hyundai Heavy Construction Equipment to build state-of-the-art earthmoving equipment to give every operator maximum performance, more precision, versatile machine preferences, and proven quality. Take pride in your work with Hyundai!

## Robex 80CR-9

### Machine Walk-Around

#### Rugged Upper and Lower Frame

The upper frame is designed with optimum structural integrity to absorb impact and operational stress. The x-style center frame and reinforced box section track frame provide exceptional strength and longer service life to withstand tough working conditions.

#### Engine Technology

The fuel efficient, Tier 4 interim certified Yanmar 4TNV98 engine provides proven, reliable power. This engine is electronically controlled for optimum fuel to air ratio and clean, efficient combustion and provides low noise, anti-restart features.

#### Efficient Control System

All control devices are arranged for higher productivity and improved operator comfort. Efficient and ergonomic controls allow an operator to control the machine in any working environment. A safety lever on the left-side console is provided to prevent exiting the cabin while hydraulic controls are live.

#### Advanced Hydraulic System

The R80CR-9's advanced hydraulic system includes an arm flow summation system, boom holding system and a swing parking brake for smooth and fine control. Other valuable features include a hydraulic damper in the travel pedal, and a hydraulically lubricated swing reducer with a leak-free grease chamber.

#### Comfortable and Durable Cabin

The cabin is roomy and ergonomically designed, for reduced noise and good visibility. The cabin frame meets international standard TOPS, ROPS, FOPS ensuring operator safety.

#### Operator Convenience

Convenient operator features include a suspension seat, excellent visibility, and variable storage space for advanced operator comfort. The newly designed LED cluster provides current information, including engine RPM, engine coolant, fuel level, and electric components. A hydraulic function safety lock and auto diagnostic features are also available. Lock and failure diagnosis functions are also integrated.

A powerful air conditioning system and Radio & USB player contribute to a productive work environment.

#### Easy and Simple Maintenance

Wide open access of doors, covers, hoods is designed for easier maintenance. The air cleaner and centralized grease fittings are also integrated for easy service.

#### Extended Life of Components

Long life components and wear parts, including hydraulic filters, oil, shims, and bushings, help to reduce operating costs.



\*Photo may include optional equipment

# Preference

The powerful and sophisticated R80CR-9 provides the operator with a large, comfortable operating environment and an ergonomically designed suspension seat with arm rests for an enhanced operating experience. For additional convenience, precision designed joystick controllers and an easy to read monitor provide the operator with quick access to information and machine control.



\*Photo may include optional equipment.

## Operator Comfort

The R80CR-9 operator's cab is designed for a comfortable operating experience. An ergonomically designed suspension seat, adjustable arm rests and a spacious environment helps to minimize operator fatigue. Control levers are easily accessible and an instrument display is provided to keep the operator informed of pertinent machine information.

1. A large upper roof glass provides additional visibility and a roller shade is provided to reduce glare and sunlight.
2. An advanced audio system with AM/FM stereo with USB player input, plus remotely located control is perfect for listening to music favorites.
3. A hands-free cell phone function is available for safe and convenient phone use.
4. Ergonomically designed joysticks reduce operator fatigue during the work day.
5. Accel dial with LED lamp is easy to control and recognizable in darkness.
6. Multiple storage compartments are available for additional convenience.



Roller shade    Radio & USB player with remote control    Hands-free cell phone    Joystick    Accel dial with LED lamp    Storage compartment

## Enhanced Cabin

Hyundai's R80CR-9 is equipped for convenience and productivity.

1. Adjustable position window prevents window movement while operating.
2. A sliding fold-in front window is easily opened and safely stored in an open position to improve ventilation and visibility.
3. A tilt-up left side control console provides easier entrance and exit from the cab.
4. A full auto air-conditioning system provides the operator with optimum air temperature.

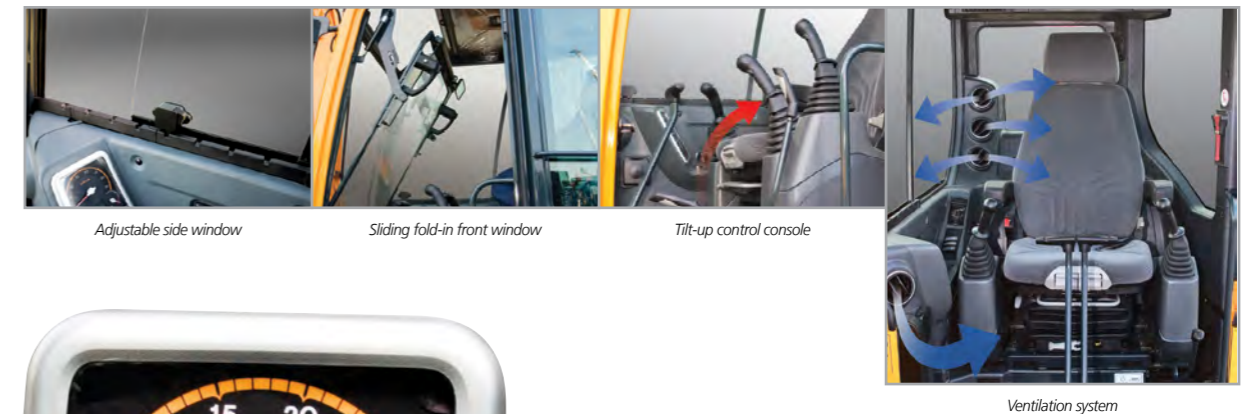

Adjustable side window    Sliding fold-in front window    Tilt-up control console    Ventilation system



## Wide Cabin with Excellent Visibility

The newly designed cabin was conceived for more space, a wider field of view and operator comfort. Special attention was given to a clear, open and convenient interior with plenty of visibility on the machine surroundings and the job at hand. This well balanced combination of precision aspects put the operator in the perfect position to work safely and securely.



## Operator - Friendly Cluster

The advanced new LED cluster allows the operator to select his personal machine preferences. The monitor displays engine rpm, engine oil temperature, water temperature and information for all electronic devices. Button selections are provided for auto idle mode, max power mode, and travel speed. A security feature is also provided to prevent the machine from starting without a proper password.

# Precision & Performance

Innovative hydraulic system technologies make the R80CR-9 excavator fast, smooth and easy to control. Also R80CR-9 is designed for maximum performance to keep the operator working productively.



\*Photo may include optional equipment.



## Boom Swing

The R80CR-9's boom swing function is designed for efficient work in congested residential and urban areas. The boom can be offset left or right within an operating range. Plus, increased swing torque provides enhanced operating capability on the slope.

## Improved Hydraulic System

Optimized matching between the joystick and main control valve improves fine control and smoothness of operation. An arm flow summation system provides energy savings, reduced cavitation and increased speed. To improve safety and avoid boom drift the R80CR-9 is equipped with an integrated boom holding system.



## Structure Strength

The R80CR-9 cabin structure has been fitted with stronger but slimmer tubing for added safety and improved visibility. Low-stress, high strength steel is integrally welded to form a stronger, more durable upper and lower frame. Structural integrity was tested by way of FEM (Finite Elements Method) analysis and long-term durability tests.

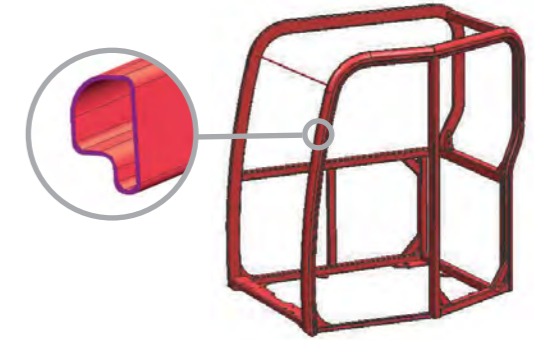

## Short Tail Swing

R80CR-9's short tail swing radius allows the operator work in confined areas like close to buildings on roadways, and in urban areas. This compact radius design provides easy and efficient operation in any limited space work environment.

## Yanmar 4TNV98

**The Highest Engine Power in its Class**

Yanmar 4TNV98 engine provides 24.5 kgf-m (177 lbf-ft) of maximum torque with 60 HP at 2,100rpm of rated power. This means the R80CR-9 runs with the most power in its class, giving you more power to get the job done.

# Profitability

R80CR-9 is designed to maximize profitability through improved efficiencies, enhanced service features and longer life components.



\*Photo may include optional equipment.



## Improved Durability

The R80CR-9's reinforced arm lug & dozer cylinder cover provide better reliability on the tough working condition.



## Easy Change Air Cleaner

The R80CR-9 is equipped with a durable plastic air cleaner designed for easy maintenance.



## Centralized Grease Fittings

A centralized lubrication bank is available for faster, easier service and maintenance.



## Wide Open Engine hood

A newly designed full-open type engine hood makes service more convenient on the R80CR-9.



## Tilting Cabin

R80CR-9's tiltable cabin provides the operator with convenient maintenance.

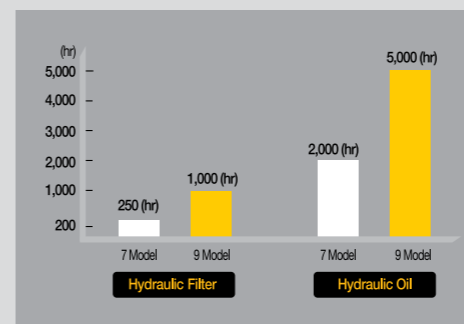

## Extended Life Components

9 series excavators were designed with bushings designed for extended lube intervals (250 hrs) & polymer shims (wear resistant, noise reducing), extended-life hydraulic filters (1,000hrs), long-life hydraulic oil (5,000hrs), more efficient cooling systems and integrated preheating systems which extend service intervals, minimize operating costs and reduce machine down time.

# Specifications

## ENGINE

MODEL	YANMAR 4TNV98		
Type	Water cooled, 4 cycle diesel 4 cylinders in line, direct injection, low emission		
Rated flywheel horsepower	SAE	J1995 (gross)	59.6 HP (44.4 kW) at 2,100 rpm
		J1349 (net)	58.2 HP (43.4 kW) at 2,100 rpm
	DIN	6271/1 (gross)	60.4 PS (44.4 kW) at 2,100 rpm
		6271/1 (net)	59.0 PS (43.4 kW) at 2,100 rpm
Max. torque	24.5 kgf-m (177 lbf-ft) at 1,350 rpm		
Bore X stroke	98 mm (3.86") x 110 mm (4.33")		
Piston displacement	3,319 cc (202 cu in)		
Batteries	2 x 12 V x 100 AH		
Starting motor	12V-3.0 kW		
Alternator	12V-80 Amp		

## HYDRAULIC SYSTEM

MAIN PUMP	
Type	Two variable displacement piston pumps + gear pump
Max. flow	2 X 72 l/min + 53.2 l/min
Sub-pump for pilot circuit	Gear pump

Cross-sensing and fuel saving pump system

HYDRAULIC MOTORS	
Travel	Two speed axial piston motor with counter balance valve and parking brake
Swing	Axial piston motor with automatic brake

RELIEF VALVE SETTING	
Implement circuits	P1 / P2 : 280 kgf/cm <sup>2</sup> (3,980 psi) P3 : 230 kgf/cm <sup>2</sup> (3,270 psi)
Travel circuit	280 kgf/cm <sup>2</sup> (3,980 psi)
Swing circuit	230 kgf/cm <sup>2</sup> (3,270 psi)
Pilot circuit	35 kgf/cm <sup>2</sup> (500 psi)
Service valve	Installed

HYDRAULIC CYLINDERS	
No. of cylinder bore X stroke	Boom: 1-115 x 850 mm (4.5" x 33.5")
	Arm: 1-100 x 870 mm (3.9" x 34.3")
	Bucket: 1-85 x 685 mm (3.3" x 27.0")
	Boom swing: 1-110 x 744 mm (4.3" x 29.3")
	Dozer blade: 1-130 x 152 mm (5.1" x 6.0")

## NOISE LEVEL (CAB)

NOSIE LEVELS (DYNAMIC VALVE)	
LwA	98 dB
LpA	78 dB

## TRAVEL SYSTEM

Drive method	Full hydrostatic type
Drive motor	Axial piston motor, in-shoe design
Reduction system	Planetary reduction gear
Max. drawbar pull	7,400 kgf (16,310 lbf)
Max. travel speed(high) / (low)	4.3 km/hr (2.7 mph) / 2.8 km/hr (1.7 mph)
Gradeability	35° (70%)
Parking brake	Multi-wet disc

## CONTROL

Pilot pressure operated joysticks and pedals with detachable lever provide almost effortless and fatigueless operation.

Pilot control	Two joysticks with one safety lever (LH): Arm swing, Boom swing (RH): Boom and bucket (ISO)
Traveling and steering	Two levers with pedals
Engine throttle	Electric, Dial type

## SWING SYSTEM

Swing motor	Axial piston motor
Swing reduction	Planetary gear reduction
Swing bearing lubrication	Grease-bathed
Swing brake	Multi wet disc
Swing speed	9.6 rpm

## COOLANT & LUBRICANT CAPACITY

(Refilling)	liter	US gal	UK gal
Fuel tank	120.0	31.7	26.4
Engine coolant	11.0	2.9	2.4
Engine oil	11.6	3.1	2.6
Final drive(each)	1.2	0.3	0.3
Hydraulic tank	71.0	18.8	15.6
Hydraulic system	120.0	31.7	26.4

## UNDERCARRIAGE

X-leg type center frame is integrally welded with reinforced box-section track frames. The undercarriage includes lubricate rollers, track adjusters with shock absorbing springs and sprockets, and track chain with triple grouser shoes.

Center frame	X - leg type
Track frame	Pentagonal box type
No. of track shoe on each side	39
No. of upper roller on each side	1
No. of lower roller on each side	5

## OPERATING WEIGHT (APPROXIMATE)

Operating weight, including 3,400 mm (12' 2") boom, 1,670 mm (5' 6") arm, SAE heaped 0.28 m<sup>3</sup> (0.37 yd<sup>3</sup>) digging bucket, lubricant, coolant, full fuel tank, hydraulic tank and the standard equipment.

MAJOR COMPONENT WEIGHT	
Upperstructure	4,090 kg (9,020 lb)
Mono boom(with arm cylinder)	550 kg (1,210 lb)

OPERATING WEIGHT		
Operating weight	Steel (450)	8,350 kg (18,410 lb)
	Steel (600)	8,510 kg (18,760 lb)
	Rubber (450)	8,250 kg (18,190 lb)

·Mono boom with blade

Ground Pressure	Steel (450)	0.39 kgf-m / cm <sup>2</sup> (5.55 psi)
	Steel (1,600)	0.30 kgf-m / cm <sup>2</sup> (4.27 psi)
	Rubber (450)	0.38 kgf-m / cm <sup>2</sup> (5.40 psi)

## BUCKETS

Capacity		Width		Weight
SAE heaped	CECE heaped	Without side cutters	With side cutters	
0.14 m <sup>3</sup> (0.18 yd <sup>3</sup> )	0.13 m <sup>3</sup> (0.17 yd <sup>3</sup> )	390 mm (15.4")	470 mm (18.5")	185 kg (410 lb)
0.28 m <sup>3</sup> (0.37 yd <sup>3</sup> )	0.25 m <sup>3</sup> (0.33 yd <sup>3</sup> )	730 mm (28.7")	810 mm (31.9")	230 kg (510 lb)

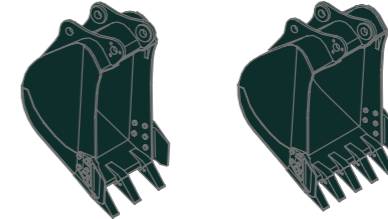



SAE heaped 0.14 m<sup>3</sup> (0.18 yd<sup>3</sup>) 0.28 m<sup>3</sup> (0.37 yd<sup>3</sup>)

## DIGGING FORCE









Bucket	1.67m Arm	2.2m Arm
	5,700 kgf	5,700 kgf
	55.9 kN	55.9 kN
Arm	12,570 lbf	12,570 lbf
	4,300 kgf	3,540 kgf
	42.2 kN	34.7 kN
	9,480 lbf	7,800 lbf

# Lifting Capacity









## R80CR-9

 Rating over-front  Rating over-side or 360 degree

Boom : 3.4m (12' 2") / Arm : 1.67 m (5' 6") / Bucket : 0.28 m<sup>3</sup> (0.37 yd<sup>3</sup>) SAE heaped / Dozer blade down

Load point height m (ft)	Load radius						At max. reach			
	1.5 m (5 ft)		3.0 m (10 ft)		4.5 m (15 ft)		Capacity		Reach	
									m (ft)	
4.5 m (15 ft)	kg lb					*1550 *3420	1480 3260	*1470 *3240	1040 2290	5.74 (17.9)
3.0m (10 ft)	kg lb					*1740 *3840	1430 3150	*1530 *3370	780 1720	6.23 (20.4)
1.5 m (5 ft)	kg lb			*4050 *8930	2510 5530	*2260 *4980	1320 2910	*1620 *3570	700 1540	6.45 (21.2)
Ground Line	kg lb			*4830 *10650	2320 5110	*2650 *5840	1230 2710	*1710 *3770	740 1630	6.20 (20.3)
-1.5 m (-5 ft)	kg lb	*4730 *10430	*4730 *10430	*4410 *9720	2320 5110	*2550 *5620	1210 2670	*1760 *3880	940 2070	5.38 (17.7)
-3.0 m (-10 ft)	kg lb			*2810 *6190	2430 5360					

Boom : 3.4m (12' 2") / Arm : 1.67 m (5' 6") / Bucket : 0.28 m<sup>3</sup> (0.37 yd<sup>3</sup>) SAE heaped / Dozer blade up

Load point height m (ft)	Load radius						At max. reach			
	1.5 m (5 ft)		3.0 m (10 ft)		4.5 m (15 ft)		Capacity		Reach	
									m (ft)	
4.5 m (15 ft)	kg lb					*1550 *3420	1380 3040	1110 2450	970 2140	5.74 (17.9)
3.0m (10 ft)	kg lb					1540 3400	1340 2950	840 1850	730 1610	6.23 (20.4)
1.5 m (5 ft)	kg lb			2770 6110	2320 5110	1430 3150	1230 2710	760 1680	650 1430	6.45 (21.2)
Ground Line	kg lb			2570 5670	2140 4720	1330 2930	1140 2510	790 1740	680 1500	6.20 (20.3)
-1.5 m (-5 ft)	kg lb	*4730 *10430	*4730 *10430	2570 5670	2140 4720	1310 2890	1120 2470	1010 2230	870 1920	5.38 (17.7)
-3.0 m (-10 ft)	kg lb			2690 5930	2250 4960					

1. Lifting capacity is based on ISO 10567.











2. Lifting capacity of the Robex Series does not exceed 75% of the tipping load with the machine on firm, level ground or 87% of full hydraulic capacity.

3. The load point is a hook located on the back of the bucket.











4. (\*) indicates the load limited by hydraulic capacity.

 Rating over-front  Rating over-side or 360 degree

Boom : 3.4m (12' 2") / Arm : 2.20 m (7' 3") / Bucket : 0.28 m<sup>3</sup> (0.37 yd<sup>3</sup>) SAE heaped / Dozer blade

Load point height m (ft)	Load radius								At max. reach			
	1.5 m (5 ft)		3.0 m (10 ft)		4.5 m (15 ft)		6.0 m (20 ft)		Capacity		Reach	
											m (ft)	
4.5 m (15 ft)	kg lb					*1180 *2600	*1180 *2600			*1280 *2820	810 1790	6.17 (20.2)
3.0m (10 ft)	kg lb					*1410 *3110	*1410 *3110	*1400 *3090	820 1810	*1320 *2910	630 1390	6.84 (22.4)
1.5 m (5 ft)	kg lb			*3280 *7230	2580 5690	*1970 *4340	1310 2890	*1570 *3460	780 1720	*1390 *3060	570 1260	7.03 (23.1)
Ground Line	kg lb	*1900 *4190	*1900 *4190	*4600 *10140	2270 5000	*2470 *5450	1190 2620	*1730 *3810	730 1610	*1460 *3220	590 1300	6.80 (22.3)
-1.5 m (-5 ft)	kg lb	*3590 *7910	*3590 *7910	*4590 *10120	2220 4890	*2580 *5690	1140 2510			*1500 *3310	720 1590	6.09 (20.0)
-3.0 m (-10 ft)	kg lb	*5800 *12790	*5800 *12790	*3530 *7780	2290 5050	*1890 *4170	1190 2620			*1360 *3000	1220 2690	4.58 (15.0)

Boom : 3.4 m (12' 2") / Arm : 2.20 m (7' 3") / Bucket : 0.28m<sup>3</sup> (0.37yd<sup>3</sup>) SAE heaped / Dozer blade up

Load point height m (ft)	Load radius								At max. reach			
	1.5 m (5 ft)		3.0 m (10 ft)		4.5 m (15 ft)		6.0 m (20 ft)		Capacity		Reach	
											m (ft)	
4.5 m (15 ft)	kg lb					*1180 *2600	*1180 *2600			870 1920	750 1650	6.17 (20.2)
3.0 m (10 ft)	kg lb					*1410 *3110	1350 2980	880 1940	760 1680	680 1500	580 1280	6.84 (22.4)
1.5 m (5 ft)	kg lb			2850 6280	2390 5270	1420 3130	1220 2690	840 1850	720 1590	610 1340	520 1150	7.03 (23.1)
Ground Line	kg lb	*1900 *4190	*1900 *4190	2520 5560	2090 4610	1290 2840	1100 2430	790 1740	670 1480	640 1410	540 1190	6.80 (22.3)
-1.5 m (-5 ft)	kg lb	*3590 *7910	*3590 *7910	2460 5420	2040 4500	1240 2730	1050 2310			780 1720	660 1460	6.09 (20.0)
-3.0 m (-10 ft)	kg lb	*5800 *12790	*5800 *12790	2540 5600	2110 4650	1290 2840	1100 2430			1320 2910	1130 2490	4.58 (15.0)

1. Lifting capacity is based on ISO 10567.

2. Lifting capacity of the Robex Series does not exceed 75% of the tipping load with the machine on firm, level ground or 87% of full hydraulic capacity.

3. The load point is a hook located on the back of the bucket.

4. (\*) indicates the load limited by hydraulic capacity.

# Lifting Capacity

## R80CR-9 DIMENSIONS

Unit : mm (ft.in)

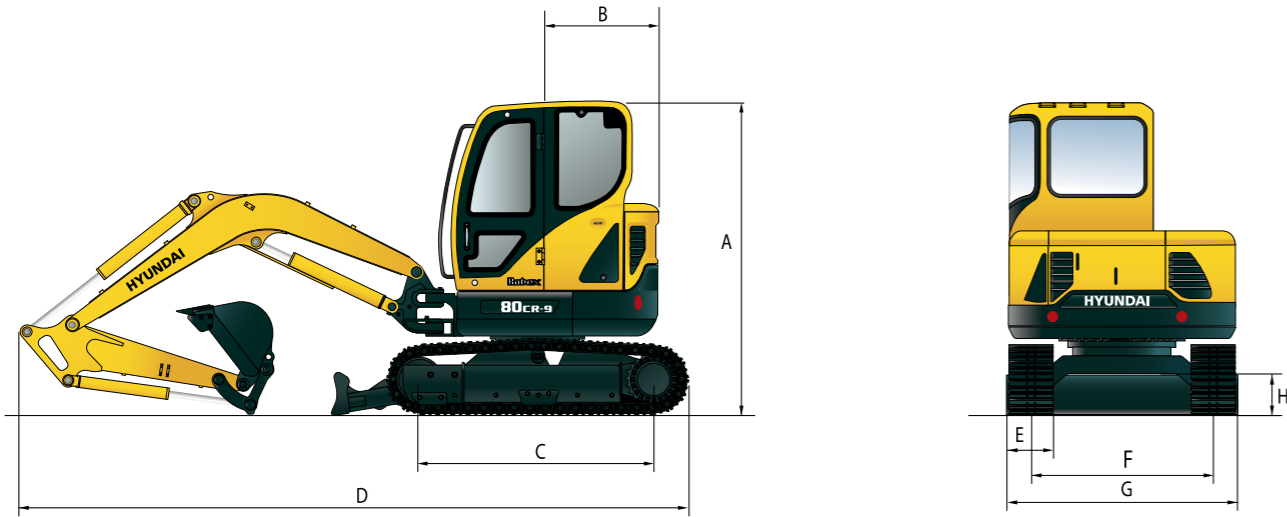

mm (ft.in)

<b>A</b> Overall height of cab	2,640 (8' 8")	<b>E</b> Track shoe width	Steel	450 (1' 6")
<b>B</b> Tail swing radius	1,280 (4' 2")		Rubber	450 (1' 6")
<b>C</b> Tumbler distance	2,200 (7' 3")	<b>F</b> Track gauge	1,850 (6' 1")	
<b>D</b> Overall length	6,170 (20' 3")	<b>G</b> Overall width	2,300 (7' 7")	
		<b>H</b> Ground clearance	360 (1' 2")	

# Dimensions & Working Range

## R80CR-9 WORKING RANGE

Unit : mm (ft.in)

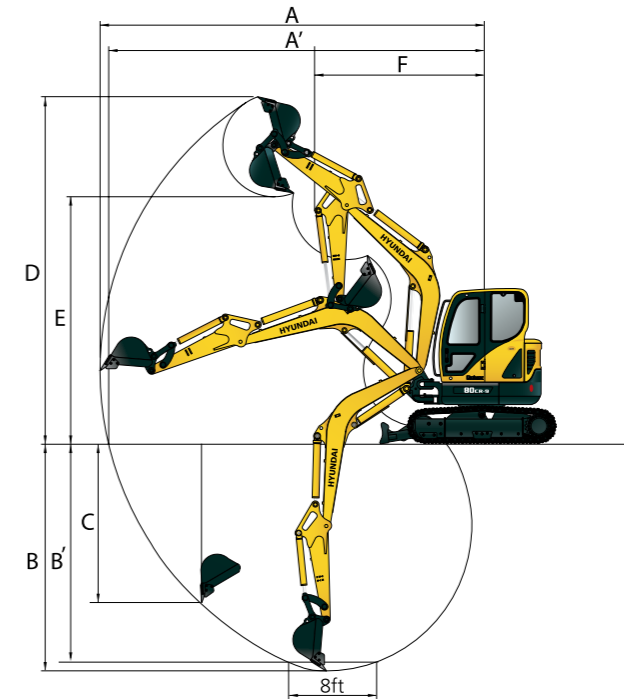

Unit : mm (ft.in)

Boom length	3,400 (11' 2")	
Arm length	1,670 (5' 6")	2,200 (7' 3")
<b>A</b> Max. digging reach	6,960 (22' 10")	7,390 (24' 3")
<b>A'</b> Max. digging reach on ground	6,820 (22' 5")	7,250 (23' 9")
<b>B</b> Max. digging depth	4,150 (13' 7")	4,620 (15' 2")
<b>B'</b> Max. digging depth (8ft level)	3,780 (12' 5")	4,330 (14' 2")
<b>C</b> Max. vertical wall digging depth	3,570 (11' 9")	4,040 (13' 3")
<b>D</b> Max. digging height	6,740 (22' 1")	7,040 (23' 1")
<b>E</b> Max. dumping height	4,730 (15' 6")	5,050 (16' 7")
<b>F</b> Tail swing radius	2,500 (8' 2")	2,610 (8' 7")