

HL975

With EU Stage V Final Engine installed

* Photo may include optional equipment.



Head Office(Sales Office)
14F, GLOBAL R&D CENTER, 477 BUNDANG SUSEO-RO, BUNDANG-GU, SEONGNAM-SI, GYEONGGI-DO, 13553, KOREA

PLEASE CONTACT

Gross Power
335 hp (250 kW) / 2,100 rpm

Net Power
331 hp (247 kW) / 2,100 rpm

Travel Speed
40.0 km/hr (24.9 mph)

Operating Weight
26500 kg / 58,420 lb

RULE THE GROUND

The HL900 Series exceeds customer's expectation!
Become a true leader on the ground with Hyundai's HL900 Series.

WORK MAX, WORTH MAX

- EU STAGE V Engine
- Smart Power Mode
- Eco Pedal **Option**
- 5 Speed Lock Up Clutch **Option**
- Hydraulic Differential Lock **Option**
- Automatic Engine Shut Down **Option**
- Eco Gauge
- ICCO (Intelligent Clutch Cut Off)
- Load Sensing Hydraulics
- Accurate Onboard Weighing System

MORE RELIABLE, MORE SUSTAINABLE

- Thermostat for Transmission Cooling **Option**
- Improved Bucket Fill Factor
- Durable Structure for After-Treatment
- Sintered Brake Disc
- Sealed Drive Line Center Bearing
- Hydraulic Hose
- Premium Quality Axles
- Axle Oil Cooling System

MODERN COMFORT, SIMPLE AND SAFE SOLUTION

- New fully openable Engine Hood for Improved Rear Visibility
- Ride Control System **Option**
- LED lamp **Option**
- Fully Adjustable Seat Armrest, Seat
- Electro-Hydraulic Implement Control
- Increased Service Life for Engine Air Filter
- Soft end Stop
- Air conditioning System
- Adjustable Joystick Steering Sensitivity **NEW** **Option**
- Electric Adjustable Heated Mirror **NEW**
- Bucket Angle Display **NEW**

INFOTAINMENT FRONTIER

- Intelligent & Wide Touch Screen Monitor
- Centralized Cluster
- Audio System
- Wifi Direct With Smart Phone
- Full Sound-Proofed Spacious Cabin
- AAVM+ **NEW** **Option**
(Advanced Around View Monitoring)
- See-Through Bucket **NEW** **Option**

OPTION SERVICEABILITY AND TELEMATICS

- Unnecessary Regular DPF Cleaning Interval
- ECD(Engine Connected Diagnostics)
- Hi MATE **Option**
- Easy Filter Replacement
- Wide Core & Fin Radiator
- Longer Lasting Filter
- Integrated Mudguard **NEW**



* Photo may include optional equipment.

 YouTube





WORK MAX, WORTH MAX

Stage-V Engine Technologies

Hyundai HL900 series wheel loaders incorporate new engine technologies for Stage-V compliance and include many new features that contribute to overall fuel and production efficiency.



Smart POWER Mode

This function detects the work load from sensors and adjusts the engine power to optimize power distribution to working and driving. This allows you to get 3-5% fuel savings.



Eco Gauge

Using this function, the operator can monitor fuel consumption in real time or review historical data. Displayed values include engine torque, fuel efficiency, average and total fuel consumed. Hourly and daily fuel consumption also is viewable through the menu.



ICCO (Intelligent Clutch Cut Off)

By selecting of 'H-Mode' among clutch cut-off selections, ICCO will be engaged for both less power loss in torque converter and lower heat generation on brake sides.

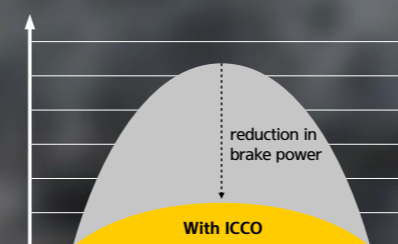

Eco Pedal **Option**

The innovative Eco Pedal helps the operator work as efficiently as possible. When working the engine throttle between zero and 85 percent of full power, fuel savings are maximized. For those tough jobs, the operator easily commands maximum performance by applying additional pressure on the Eco Pedal to gain up to 100 percent of available engine power.



Automatic Shut-Down of Engine (Only Button Key) **Option**

This system turns off the engine when entering idle state to minimize unnecessary fuel consumption and emissions. Operators can select the operating mode and idle time, depending on the work condition, which contributes to overall fuel efficiency.



Hydraulic Lock Differential **Option**

Option

Hydraulic Lock Differential has the advantages of both improving productivity and less fuel consumption by preventing tire slip during the operation.



5 Speed Lock-up Clutch **Option**

With the five-speed transmission and lockup clutch, operators can select the appropriate gear for their work conditions, thereby reducing fuel consumption.



Load Sensing Hydraulics

With precise load sensing and the higher efficiency on control of piston pump, the load sensing contributes to reduce the fuel consumption by discharging the minimum oil pressure and flow.

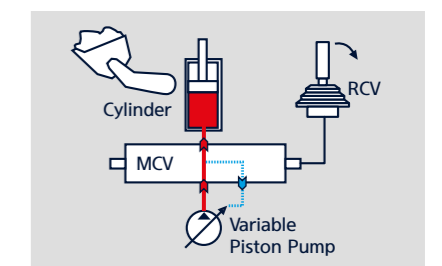

Accurate Onboard Weighing System

All Hyundai HL900 series models include Hyundai's proprietary onboard weighing system as standard equipment. Accurate to +/- 1 percent, the system has automatic and manual settings for monitoring individual and cumulative bucket load weights. System measurements are displayed on the multi-function screen in the cab, providing load-weight monitoring reliable enough to support production management.

* Photo may include optional equipment.

Improved Bucket Fill Factor

Hyundai's improved bucket design features an innovative wider opening, curved side plates and enhanced spill guard to maximize bucket capacity and minimize material loss when traveling. Durability is also enhanced through the use of high wear-resistant steel in key structural areas of the bucket.

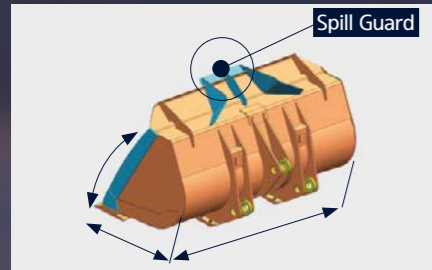

Sintered Brake Disc

The HL900 series features longer-lasting sintered brake discs designed to produce less heat and vibration, which improves overall brake durability. This service-friendly design contributes to reduced downtime for brake maintenance and reduces overall cost of ownership.



Durable Structure for After-Treatment

The New HL975 wheel loaders are equipped with a robust support and shock absorbing system to prevent failure of after-treatment system components during operation.



Sealed Drive Line Center Bearing

Hyundai's wheel loaders are designed for extended service life. A sealed drive-line center bearing with a reinforced support area contributes to improved long-term reliability.

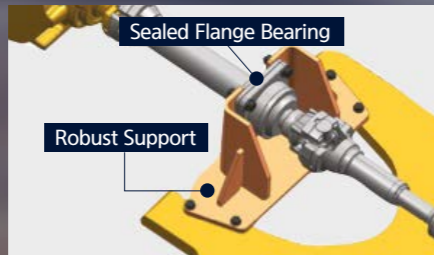

Hydraulic Hose

Hyundai provides high quality hydraulic hoses, which are three to four times more durable than other hoses commonly found in the industry.



Premium Quality Axles

Through enhanced axles, stable driving is possible even in various ground conditions.



Axle Oil Cooling System

A separate cooling system prevents overheating of axle oil caused by frequent braking and high-load work.

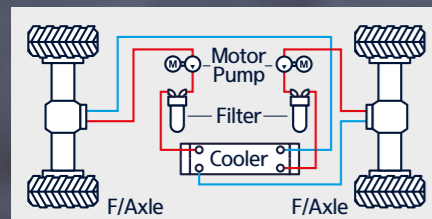

Thermostat for Transmission Cooling

Option
With thermostat for transmission cooling, temperature of fluid increases rapidly and remains at optimal temperature during winter season, thereby achieving quick warm, protection of functional parts, and the higher efficiency.

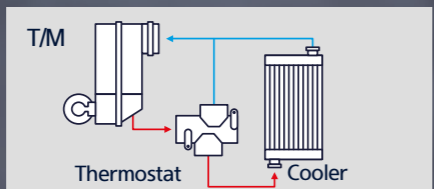

MORE RELIABLE, MORE SUSTAINABLE

New Exterior Design for More Robustness and Safety

The true value of the HL900 Series, which is now far more powerful, is revealed in tough working environments. With the high-strength design structure and enduring system proven by rigorous road tests at various work sites, Hyundai's wheel loaders can perform any high-load work to maximize productivity. Durability of frames and attachments has been enhanced by 1.5 times compared to the previous generation 9-series.



Fully Adjustable Seat Armrest, Seat

New HL975 wheel loader is equipped with large, comfortable, high-quality seats with headrests. The armrest and controller are mounted to the seat so they move with the operator, which improves comfort and reduces fatigue.



Electro-Hydraulic Implement Control

Hyundai's wheel loaders have an electro-hydraulic implement control lever. Operators can operate attachments with less strength, enabling greater productivity and minimizing fatigue of operators. (Roller switch for AUX SPOOL Control)

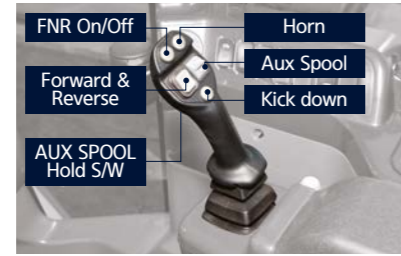

Increased Service Life for Engine Air Filter

The New HL975 has a durable wide fin cooler preventing performance degradation caused by alien substances. The New HL975 is equipped with the reversal fan to eliminate many kinds of debris.

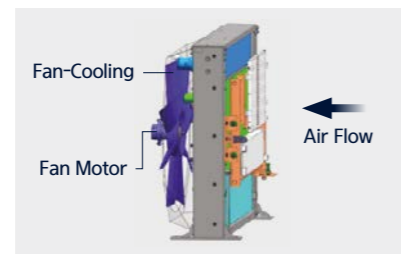

New fully openable Engine Hood for Improved Rear Visibility

The shape of engine hood is changed to improve the rear visibility of the equipment, and the entire hood is opened to improve the accessibility of the engine room for easy maintenance.



AAVM+(Advanced Around View Monitoring) **NEW** **Option**

This is a system that is combined AVM (Around View Monitoring) with IMOD (Intelligent Moving Object Detection) and detects people around the machine and analyzes the images, which displays a warning sign on a monitor when detecting the danger. So operators can watch the surroundings in a variety of angles through the monitor and prevent the safety accident in advance.



It offers **reverse guidelines** and a feature that alerts you only to objects detected in the reversing path.



It enhances safety by improving monitor visibility in areas obscured by the bucket.

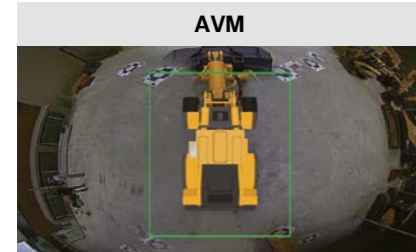

AVM

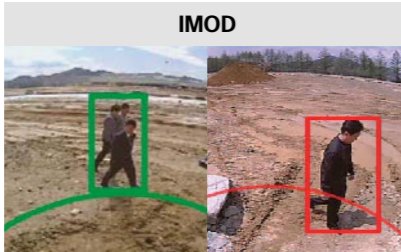

IMOD

Electric Adjustable Heated Mirror **NEW**

The electrically adjustable heated mirrors can be controlled from inside the cabin with a switch, offering angle adjustment and a heating function to enhance operator convenience.



Ride Control System **Option**

Ride control system with piston accumulator, which reduces the pitch of body and bucket of wheel loader, minimizes spillover and contributes to increase convenience.

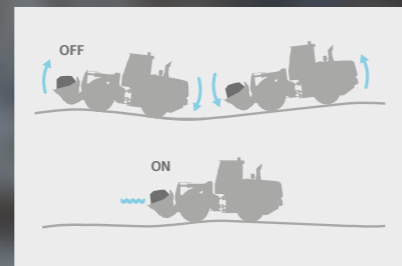

Soft end Stop

This function reduces the hydraulic speed of the cylinder as it reaches the end of its stroke. This lessens the shock load of the stroke, which improves material retention, while increasing operator comfort and productivity.

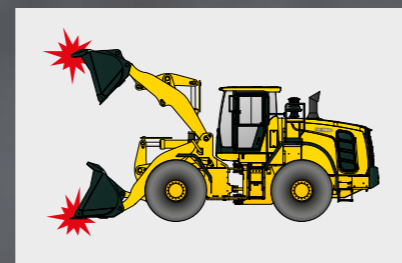

MODERN COMFORT, SIMPLE AND SAFE SOLUTION

New Cabin for More Comfort

With top priority on satisfaction of operators in terms of silence, safety, and maintainability, Hyundai's wheel loaders provide comfortable cabin space for operators by low-vibration, low-noise, and superior safety design. They also offer greater satisfaction by extending the replacement cycle of supplies and minimizing maintenance time and cost.





INFOTAINMENT FRONTIER

Enhanced Instrument Panel for Easier Monitoring

The HL900 Series is optimized to enable operators to access accurate equipment data in a timely manner. This feature is more important in tough working environments to increase productivity while enjoying various forms of entertainment. Enjoy unparalleled satisfaction provided by infotainment of Hyundai's state-of-the-art information technology!

Intelligent & Wide Touch Screen Monitor

The seven-inch capacitive-type display (like a smart phone display) of the HL900 Series is larger than the previous model and provides excellent legibility. Audio AUX maximizes convenience of operators.



Centralized Cluster

With a centralized cluster, operator can see at a glance all the states of wheel loader.



Audio System

The radio with MP3 functions, the integrated Bluetooth hands-free feature, and the built-in microphone allow for phone calls and for listening to music while in the field.



Wifi Direct With Smart Phone (Smart Terminal)

The Miracast system connects to an operator's smartphone via the phone's Wi-Fi. This enables operators to view their phone screen on the monitor for web surfing, videos and/or music.



Full Sound-Proofed Spacious Cabin

The state-of-the-art noise reduction technology found on the HL900 series models results in one of the quietest working environments in the industry. In-cab sound levels are as low as 73 dB.



Photo may include optional equipment.



SERVICEABILITY AND TELEMATICS

IoT, ICT, AI-based digital technologies is creating smart construction sites. Maximizes connectivity, productivity, and safety for your successful businesses.



*Photo may include optional equipment.

Hi MATE

Option

IT'S CONVENIENT, EASY AND VALUABLE

Hi MATE Hyundai's newly developed remote management system, utilizes GPS-satellite technology to provide customers with the highest level of service and product support available. Hi MATE enables users to remotely evaluate machine performance, access diagnostic information, and verify machine locations at the touch of a button.

WHAT IS BENEFITS



Increase Productivity

It helps you operate machines in efficient. You can check the difference between total engine hours and actual working hours. See how productive your machines are and plan any required cost saving solutions. Hi MATE offers working information such as working / idling hours, fuel consumption and rate.



Convenient and Easy Monitoring

There is nothing much to do to monitor your machines. Just log on to the Hi MATE website or mobile application. Hi MATE allows you to watch your machines whenever and wherever you are.



Security

Protect your machines from theft or unauthorized usage with Hi MATE. If the machine moves out of the Geofence boundary, you will get alerts.

Unnecessary Regular DPF Cleaning Interval

Regular ash cleaning for DPF is not necessary, only needed as indicated by fault-indicator lamp.

ECD(Engine Connected Diagnostics)

It supports service technician with remote diagnostics report and ensure it arrive on site with proper tools after preparing in advance.

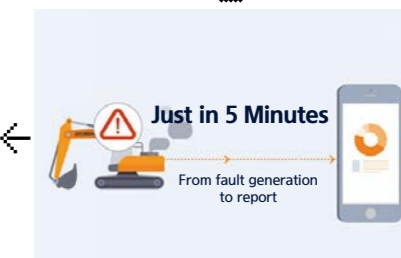
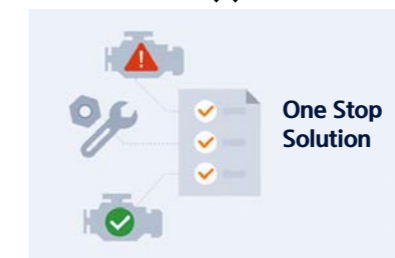

Fully Openable Engine Hood

The HL975 has improved accessibility to the sealed engine room with retractable hood to allow easy cleaning and maintenance. The engine room was designed to prevent possibility of fire due to inflow of foreign materials. The fully retractable engine hood in the electric actuator opening mode also enhances maintainability of the engine room and cooling room.



Easy Filter Replacement

With easy filter replacement, machine can be managed more easily.



Wide Core & Fin Radiator

Wide core & fin radiator reduces clogging.



SPECIFICATIONS

ENGINE

Maker / Model	Cummins / X12
Type	6 cylinder, water cooled, 4-cycle, turbocharged, charge air cooled, direct injection, electronic controlled diesel engine
Gross Power (SAE J1995)	335 HP (250 kW) at 2,100 rpm
Net Power (SAE J1349)	331 HP (247 kW) at 2,100 rpm
Max. Power	381 HP (284 kW) at 1,700 rpm
Peak Gross Torque (SAE J1995)	1746 N·m (1,287 lb.ft) at 1,400 rpm
Displacement	11.8 ℓ (720 cu in)

HYDRAULIC SYSTEM

Type	Load sensing hydraulic system
Pump	Variable displacement piston pump 386 lpm
Control Valve	2 Spool (Bucket, Boom) 3 Spool (Bucket, Boom, Aux)
System Pressure	280 bar (4,061 psi)
Lift Circuit	The valve has four functions: Raise / Hold / Lower / Float Can adjust automatic kickout from horizontal to full lift.
Tilt Circuit	The valve has three functions: Tilt back / Hold / Dump Can adjust automatic bucket positioner to desired load angle.
Cylinder	Type: double acting No. of cylinders-bore × stroke Lift 2-170 × 795 mm (2-6.7" × 31.3") HL975 Tilt 1-190 × 565 mm (1-7.5" × 22.2") HL975XT Tilt 1-190 × 585 mm (1-7.5" × 23.0")
Cycle Time	Raise : 5.9 Sec. / Dump : 1.7 Sec. Lower : 3.9 Sec. / Total : 11.5 Sec.

* Hyundai Bio Hydraulic Oil (HBHO) available

TRANSMISSION

Torque Converter Type	3-Elements, Single-stage, Single phase
Tire	26.5R25, ★★, L3

TRANSMISSION

Travel Speed	4 speed T/M		5 Speed T/M with lock up clutch	
	km/h (mph)		km/h (mph)	
Forward	1st	6.6 (4.1)	6.5 (4.0)	
	2nd	11.0 (6.8)	11.0 (6.8)	
	3rd	24.6 (15.3)	17.6 (10.9)	
	4th	36.5 (22.7)	25.2 (15.7)	
	5th	-	40.0 (24.9)	
Reverse	1st	6.6 (4.1)	6.5 (4.0)	
	2nd	11.0 (6.8)	11.0 (6.8)	
	3rd	24.6 (15.3)	17.6 (10.9)	

AXLES

Drive System	Four-wheel drive system
Mount	Fixed
Rear Axle Oscillation	Oscillating ± 11 degrees
Hub Reduction	Planetary reduction at wheel end
Differential	Conventional
Reduction Ratio	24.666

TIRES

Type	Tubeless, loader design tires
Standard	26.5R25, ★★, L3
Options Include	26.5R25, ★★, XHA2 26.5-25, 28PR, L3 26.5-25, 32PR, L3

OVERVIEW

Description	HL975	HL975 XT
Operating Weight	26,500 kg (58,420 lb)	27,295 kg (60,175 lb)
Bucket Capacity	Heaped 4.80 m ³ (6.30 yd ³) Struck 4.10 m ³ (5.30 yd ³)	4.80 m ³ (6.30 yd ³) 4.10 m ³ (5.30 yd ³)
Breakout Force-Bucket	23,435 kg (51,665 lb)	23,295 kg (51,355 lb)
Tipping Load	Straight 20,000 kg (44,090 lb)	18,300 kg (40,340 lb)
	Full Turn 17,300 kg (38,140 lb)	15,700 kg (34,610 lb)

BRAKES

Service Brakes	Hydraulically actuated, wet disc brakes actuate all 4 wheels independent axle-by-axle system. Self adjusting & wheel speed brake.
Parking Brake	Spring-applied, hydraulically released brake
Emergency Brake	When brake oil pressure drops, indicator light alerts operator and parking brake automatically applies.

STEERING SYSTEM

Type	Load sensing hydrostatic articulated steering
Pump	Variable displacement piston pump, 231 lpm
System Pressure	210 bar (3,046 psi)
Cylinder	Double acting 2-100 × 468 mm (2-3.9" × 18.4")
Steering Angle	40° to both right and left angle, respectively
Features	Center-point frame articulation. Tilt and telescopic steering column.

SERVICE REFILL CAPACITIES

Fuel Tank	400 liters (105.6 US gal)
Def Tank	49.2 liters (15.0 US gal)
Cooling System	46.0 liters (12.2 US gal)
Crankcase	34.0 liters (9.0 US gal)
Transmission	55.0 liters (14.5 US gal)
Front Axle	51.0 liters (13.5 US gal)
Rear Axle	40.0 liters (10.6 US gal)
Hydraulic Tank	151 liters (39.8 US gal)
Hydraulic System (Including Tank)	285 liters (75.2 US gal)

CABIN

ROPS / FOPS meet ISO 3471 and ISO 3449

SOUND

Guaranteed noise level presented below can be differed depending on a range of factors such as operating condition, speed of a cooling fan, types of engine and so forth. Hearing protection shall be necessary if an operator is working in the improperly maintained cabin or exposed to a noisy environment by leaving doors and/or windows open.

Operator sound pressure level (ISO 6396:2008)	73 dB(A)
Exterior sound power level (ISO 6395:2008)	108 dB(A)

* Distance of 15 m (49.2 ft), moving forward in second gear ratio.

DIMENSIONS & SPECIFICATIONS

DIMENSIONS

All dimensions are approximate.

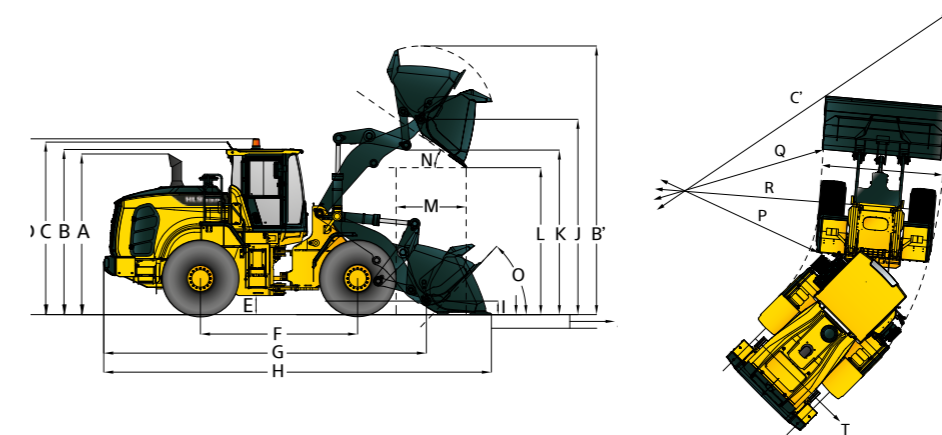

Unit : mm (ft · in)

Description	HL975	HL975 XT
A Height to Top of Exhaust Pipe	3,515 (11' 6")	3,515 (11' 6")
B Height to Top of Cabin	3,590 (11' 9")	3,590 (11' 9")
C Height to Top of Product Link Antenna	3,990 (13' 1")	3,990 (13' 1")
D Height to Top of Warning Beacon	3,720 (12' 2")	3,720 (12' 2")
E Ground Clearance	460 (1' 6")	460 (1' 6")
F Wheelbase	3,550 (11' 8")	3,550 (11' 8")
G Overall Length (Without Bucket)	7,780 (25' 6")	8,215 (26' 11")
H Shipping Length (With Bucket Level on Ground)	9,205 (30' 2")	9,640 (31' 8")
I Hinge Pin Height at Carry Position	520 (1' 8")	635 (2' 1")
J Hinge Pin Height at Maximum Lift	4,425 (14' 6")	4,790 (15' 9")

Description	HL975	HL975 XT
K Lift Arm Clearance at Maximum Lift	3,755 (12' 4")	4,105 (13' 6")
L Dump Clearance at Maximum Lift and 45° Discharge	3,120 (10' 3")	3,485 (11' 5")
M Reach at Maximum Lift and 45° Discharge	1,335 (4' 5")	1,420 (4' 8")
N Dump Angle at Maximum Lift and Dump (on Stops)	48	48
O Roll Back Angle	Ground 43 Carry 48	43 49
P Clearance Circle (Diameter) to Outside of Tires	13,045 (42' 10")	13,045 (42' 10")
Q Clearance Circle (Diameter) to Inside of Tires	6,965 (22' 10")	6,965 (22' 10")
R Width Over Tires (Unloaded)	2,975 (9' 9")	2,975 (9' 9")
S Tread Width	2,300 (7' 7")	2,300 (7' 7")

OPERATING SPECIFICATIONS WITH BUCKETS

Linkage Bucket Type	Edge Type	Standard Linkage General Purpose - Pin On						High Lift Linkage Change
		Bolt - On Cutting Edges		Bolt-On Cutting Edges		Bolt-On Cutting Edges		
Capacity - Rated	m ³ (yd ³)	4.80 (6.28)	5.20 (6.80)	4.60 (6.02)	5.00 (6.54)	4.60 (6.02)	5.00 (6.54)	-
Capacity - Rated at 110% Fill Factor	m ³ (yd ³)	5.28 (6.91)	5.72 (7.48)	5.06 (7.50)	5.50 (7.19)	5.06 (6.62)	5.50 (7.19)	-
Width	mm (ft/in)	3,250 (10' 8")	3,250 (10' 8")	3,300 (10' 10")	3,300 (10' 10")	3,320 (10' 11")	3,320 (10' 11")	-
Dump Clearance at Maximum Lift & 45° Discharge	mm (ft/in)	3,120 (10' 3")	3,075 (10' 1")	2,995 (9' 10")	2,950 (9' 8")	2,960 (9' 9")	2,915 (9' 7")	365 (1' 2.4")
Reach at Maximum Lift & 45° Discharge	mm (ft/in)	1,335 (4' 5")	1,385 (4' 7")	1,420 (4' 8")	1,470 (4' 10")	1,445 (4' 9")	1,495 (4' 11")	85 (3.4")
Digging Depth	mm (ft/in)	100 (3.9")	100 (3.9")	125 (4.9")	125 (4.9")	135 (5.3")	135 (5.3")	40 (1.6")
H Shipping Length (with Bucket)	mm (ft/in)	9,205 (30' 2")	9,270 (30' 5")	9,355 (30' 8")	9,420 (30' 11")	9,400 (30' 10")	9,465 (31' 0")	435 (1' 5")
B' Overall Height with Bucket at Maximum Lift	mm (ft/in)	6,090 (19' 12")	6,225 (20' 5")	6,090 (19' 12")	6,225 (20' 5")	6,090 (19' 12")	6,225 (20' 5")	365 (1' 2.4")
C' Loader Clearance Circle with Bucket at Carry Position	mm (ft/in)	14,730 (48' 4")	14,780 (48' 6")	14,880 (48' 10")	14,930 (48' 12")	14,930 (48' 12")	14,980 (49' 2")	370 (1' 26")
Static Tipping Load, Straight (No Tire Deflection)	kg (lb)	20,000 (44,092)	19,755 (43,552)	20,290 (44,732)	20,045 (44,192)	20,290 (44,732)	20,045 (44,192)	-1,700 (-3,748)
Static Tipping Load, Articulated (No Tire Deflection)	kg (lb)	17,300 (38,140)	17,090 (37,677)	17,550 (38,691)	17,340 (38,228)	17,550 (38,691)	17,340 (38,228)	-1,600 (-3,527)
Breakout Force	kg (lb)	23,435 (51,665)	22,425 (49,439)	24,725 (54,509)	23,590 (52,007)	24,725 (54,509)	23,590 (52,007)	-145 (-320)
Operating Weight*	kg (lb)	26,500 (58,420)	26,625 (58,698)	26,395 (58,191)	26,520 (58,467)	26,395 (58,191)	26,520 (58,467)	795 (1,753)

* All height and tire related dimensions are with standard 26.5R25, ★★, L3 tires.

BUCKET SELECTION CHART

DENSITY OF OPERATING MATERIALS		
Loose Material	Material Density [ton / m ³]	
Earth / Clay	1.5 ~ 1.7	
Sand and Gravel	1.5 ~ 1.7	
Aggregate	25 ~ 76 mm (1 " to 3 in)	1.6 ~ 1.7
	19mm (0.75 in) and Smaller	1.8

HL975 BUCKET SELECTION CHART

Standard Lift Arm - General Purpose Bucket

Type	m ³ (yd ³)	Material Density [ton / m ³]																	
		0.8	0.9	1.0	1.1	1.2	1.3	1.4	1.5	1.6	1.7	1.8	1.9	2.0	2.1	2.2	2.3	2.4	2.5
Cutting Edge	4.8 (6.28)	5.5 m ³ (7.19 yd ³)												4.6 m ³ (6.02 yd ³)					
Cutting Edge	5.2 (6.8)	6.0 m ³ (7.85 yd ³)									4.9 m ³ (6.41 yd ³)								
1-Bolt on tooth	4.6 (6.02)	5.3 m ³ (6.93 yd ³)												4.4 m ³ (5.75 yd ³)					
1-Bolt on tooth	5.0 (6.54)	5.8 m ³ (7.59 yd ³)									4.8 m ³ (6.23 yd ³)								
2-Bolt on tooth	4.6 (6.02)	5.3 m ³ (6.93 yd ³)												4.4 m ³ (5.75 yd ³)					
2-Bolt on tooth	5.0 (6.54)	5.8 m ³ (7.59 yd ³)									4.8 m ³ (6.23 yd ³)								

High Lift Arm - General Purpose

Type	m ³ (yd ³)	Material Density [ton / m ³]																	
		0.8	0.9	1.0	1.1	1.2	1.3	1.4	1.5	1.6	1.7	1.8	1.9	2.0	2.1	2.2	2.3	2.4	2.5
Cutting Edge	4.8 (6.28)	5.5 m ³ (7.19 yd ³)												4.6 m ³ (6.02 yd ³)					
Cutting Edge	5.2 (6.8)	6.0 m ³ (7.85 yd ³)									4.9 m ³ (6.41 yd ³)								
1-Bolt on tooth	4.6 (6.02)	5.3 m ³ (6.93 yd ³)												4.4 m ³ (5.75 yd ³)					
1-Bolt on tooth	5.0 (6.54)	5.8 m ³ (7.59 yd ³)									4.8 m ³ (6.23 yd ³)								
2-Bolt on tooth	4.6 (6.02)	5.3 m ³ (6.93 yd ³)												4.4 m ³ (5.75 yd ³)					
2-Bolt on tooth	5.0 (6.54)	5.8 m ³ (7.59 yd ³)									4.8 m ³ (6.23 yd ³)								

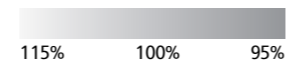

STANDARD / OPTION

CAB & INTERIOR	STD	OPT
Alternator, 110A	●	
ALARMS, AUDIBLE AND VISUAL		
Emergency Warning Lamp	●	
Engine Coolant Temperature	●	
Transmission Oil Temperature	●	
Hydraulic Oil Temperature	●	
Service brake oil pressure	●	
Fuel Level	●	
Transmission Error	●	
Air Filter Clogging	●	
Engine Oil Pressure	●	
Parking brake	●	
Battery Voltage	●	
Brake Oil Pressure	●	
Engine Stop	●	
Engine Coolant Level	●	
Alarm, back-up	●	
BATTERIES		
1,315 CCA, 12 V, 2 pcs	●	
GAUGES		
Engine Coolant Temperature	●	
Fuel Level	●	
Transmission Oil Temperature	●	
Speedometer	●	
Horn, electric	●	
INDICATOR LIGHTS		
Torque converter lock up		●
High beam	●	
Turn signal	●	
FNR joystick steering		●
Pilot cut off	●	
LCD DISPLAY		
Clock and fault code	●	
Operating hour counter	●	
Engine rpm	●	
Transmission gear range	●	
Indicator	●	
Job time and distance	●	
Temperature (coolant, hydraulic oil, T/M oil)	●	
LIGHTING SYSTEM		
LED Dome Light	●	
2 Stop and Tail Lights	●	
4 Turn Signals	●	
Brake Lights (Counterweight)	●	
2 Head Lights on Front Tower	●	
2 Working Lights on Front Roof	●	
4 Working Lights on Front Roof, 2 Working Lights on Rear Roof		●
4 Working Lights (LED) on Front Roof, 2 Working Lights (LED) on Rear Roof		●
2 Working Lights on Grill	●	
2 Working Lights (LED) on Grill		●
SWITCHES		
Hazard	●	
Selective Catalytic Reduction	●	
Engine Hood Open	●	
Parking	●	
Battery Master Switch	●	
FNR Shifter	●	
Differential Lock		●
Pilot Cut Off	●	
Secondary Steering	●	

CAB & INTERIOR	STD	OPT
IGNITION		
Key	●	
Button		●
MEMBRANE SWITCHES IN MONITOR		
Main Light	●	
Work Light	●	
Auto Grease		●
Quick Coupler		●
Ride Control		●
Work load	●	
Beacon Light		●
Rear Wiper	●	
Mirror Heat	●	
Auto Position	●	
Fine Modulation	●	
CABIN (SOUND SUPPRESSED)		
Cigar Lighter & Ashtray	●	
Coat Hook	●	
DOOR		
Door and Cabin Locks, One Key	●	
Doors, Service Access (Locking)		●
Doors, Service Access (Remote Control)		●
AUTOMATIC CLIMATE CONTROL		
Air Conditioner and Heater	●	
Defroster	●	
Intermittent Wiper and Washer, Front and Rear	●	
SEAT		
2" Retractable Seat Belt & Adjustable Mechanical Suspension (heated)	●	
2" Retractable Seat Belt & Adjustable Air Suspension (heated)		●
3" Retractable Seat Belt & Adjustable Mechanical Suspension (heated)		●
PERSONAL STORAGE SPACE		
Console Box	●	
Holder, Can and Cup	●	
Rear View Mirrors (1 inside)	●	
Rear View Mirrors (2 outside)	●	
Steering Column, Tilt and Telescopic	●	
Steering Wheel with Knob	●	
Roller Type Sunshade (Front Window)	●	
Roller Type Sunshade (Rear Window)		●
Tinted Safety Glass	●	
One Door Cab	●	
Magazine Pocket	●	
PEDALS		
One Accelerator Pedal	●	
One Brake Pedal	●	
Dual-Brake Pedal		●
Radio / USB player	●	
Rubber Floor Mat	●	
Wrist Rest	●	
24-Volt to 12-Volt DC Converter (20A)		●

STANDARD / OPTION

MEMO

ENGINE	STD	OPT
ENGINE, CUMMINS, X12		
STAGE V	●	
Engine Enclosure, Lockable	●	
Fan guard	●	
Fuel/water Separator	●	
CLEAN EMISSION MODULE		
DOC, DPF and SCR	●	
Rain Cap, Engine Air Intake	●	
Radiator	●	
Fuel Warmer	●	
Coolant Level Sight Gauge	●	
Engine Oil Level Dipstick Gauge	●	
3 Stage Air Precleaner		●
POWER TRAIN	STD	OPT
Service brake (enclosed wet-disk)	●	
Parking brake	●	
Torque converter	●	
Limited slip differential (front, rear)	●	
Hydraulic lock differential (front)		●
Axle Cooling System		●
TRANSMISSION		
Transmission F4 / R3, Computer Controlled, Electronic Soft Shift, Auto-Shift And Kick-Down Features Included	●	
Transmission F5 / R3 with lock-up clutch & Thermostat		●
Transmission Oil Sight Level	●	
Transmission oil cooler	●	
Transmission oil cooler with thermostat		●
TIRES		
26.5R25, ★★, L3	●	
26.5R25, ★★, XHA2		●
26.5-25, 28PR, L3		●
26.5R25, ★★, L4		●
Travel speed limiter (20-40 km/h)		●
HYDRAULIC SYSTEM	STD	OPT
Boom Kickout, Automatic	●	
Bucket Positioner, Automatic	●	
Diagnostic Pressure Taps	●	
Hydraulic Oil Cooler	●	
Joystick Control (EH control)	●	
Lever Control-Signle Axle (EH control)		●
Joystick Steering		●
Ride Control System		●
Secondary Steering System		●
Extra Piping-for Auxiliary Function		●
Quick Coupler Piping		●
Auto Grease System		●
Hyundai Bio Hydraulic Oil (HBHO)		●

OTHER	STD	OPT
Articulation Locking Bar	●	
Counterweight	●	
Optional Counterweight		●
Door and cab locks, one key	●	
Doors, service access (locking)	●	
Drawbar with pin	●	
Fenders (front / rear)	●	
Hydraulic oil level sight gauge	●	
Lift and tie-down hooks	●	
Loader linkage, sealed	●	
Z-bar design	●	
Vandalism protection caplocks	●	
Tool kit		●
Quick Coupler		●
ERGONOMICALLY LOCATED AND SLIP RESISTANT, LEFT & RIGHT		
Handrails	●	
Ladders	●	
Platforms	●	
Steps	●	
BUCKET		
4.8m ³ Bolt-on Cutting Edge Type Bucket	●	
5.2m ³ Bolt-on Cutting Edge Type Bucket		●
4.6m ³ Bucket 1-Bolt-on Tooth Type		●
5.0m ³ Bucket 1-Bolt-on Tooth Type		●
4.6m ³ Bucket 2-Bolt-on Tooth Type		●
5.0m ³ Bucket 2-Bolt-on Tooth Type		●
GUARDS		
Crankcase		●
Transmission		●
Cabin Glass (Front / Rear)		●
Wheel chock		●
License plate & lamp (LED)		●
Hi MATE (Remote Management System)		●
Mud Guard		●
SAFETY	STD	OPT
Rearview camera		●
AAVM+(Advanced Around View Monitoring)		●
See-through Bucket		●
Beacon light, rotating (Halogen)		●
LED beacon light		●
Fire extinguisher		●
Boom safety lock		●
LED rear combi lamp		●
LED head light		●

* Standard and optional equipment may vary. Contact your Hyundai dealer for more information. The machine may vary according to International standards.
 * The photos may include attachments and optional equipment that are not available in your area.
 * Materials and specifications are subject to change without advance notice.
 * All imperial measurements rounded off to the nearest pound or inch.