

HW210A

With EU Stage V Engine Installed

* Photo may include optional equipment.



Head Office(Sales Office)
14F, GLOBAL R&D CENTER, 477 BUNDANG SUSEO-RO, BUNDANG-GU, SEONGNAM-SI, GYEONGGI-DO, 13553, KOREA

PLEASE CONTACT

2026. MAR

Gross Power
129 kW (173 hp) at 2,200 rpm

Net Power
127 kW (170 hp) at 2,200 rpm

Bucket Capacity
0.80 m³ ~ 1.34 m³

Operating Weight
21,180 kg (46,690 lb, mono boom)
22,510 kg (49,630 lb, 2pcs boom)

HYUNDAI

WHAT'S NEWEST AND BEST

HW210A

THE BEST PRODUCTIVITY AND FUEL EFFICIENCY

- EU STAGE V Engine
- EPFC System
- Attachment Flow Control **Option**
- ECO Gauge
- Enlarged Air Inlet with Grill Cover
- Cycle Time Improvement

ULTIMATE DURABILITY

- Counterweight design **NEW**
- Reinforced Pins, Bushings and Polymer Shims
- Improved Outrigger **Option**
- Hi-grade (High-pressure) Hoses

EASY CONTROL AND COMFORTABLE OPERATION

- FNR and Ram Lock Switch on Joystick
- Bucket-Clamshell Adaptation **Option**
- Proportional Joysticks and Pedal Control **Option**
- Automatic digging brake **Option**
- Joystick steering **Option**
- Swing Lock System **Option**
- Fine Swing Control **Option**
- Proportional Auxiliary Hydraulic Lines **Option**
- Intelligent and Wide Cluster
- Jog Dial Module
- USB-MP3-Handsfree Audio System
- Dual mirror **NEW**
- A&C Type USB **NEW**

THE ULTIMATE SAFE ENVIRONMENT

- Auto Safety Lock
- 4 Lamps on Cabin **NEW** **Option**
- LED Front Lamp **NEW**
- Rear and Mirror view Camera **Option**
- Improvement Radar & 10" 2nd Monitor **Option** **NEW**
- SAVM (Smart Around View Monitoring) Camera System **Option** **NEW**
- Cruise Control & Speed Limiter **Option**
- Seatbelt Warning Signal
- Half Bar Beacon Lamp **Option** **NEW**
- Over Swing Lock **NEW**
- Built-in Camera **NEW**

SERVICEABILITY AND TELEMATICS

- Hi MATE **Option**
- ECD(Engine Connected Diagnostics)
- Mobile Fleet App
- Easy Access to DEF/AdBlue® Supply System
- HCE-DT Air
- Longer Lasting Filter



* Photo may include optional equipment.

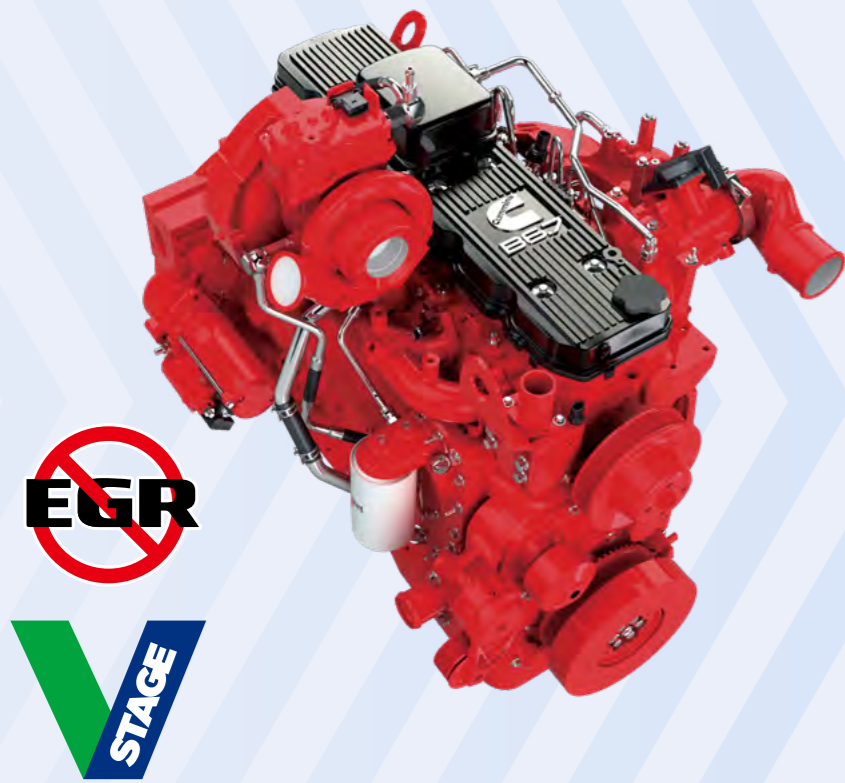

EU Stage V Certified Engine

Cummins B6.7 engine is satisfying the most strict environmental emission regulation in the world. (Reduction in PM 60%)

EU STAGE V Engine

Now in its fourth decade of continuous improvement, the B6.7 for 2019 features an EGR-free design that delivers 5 percent more power and 31 percent more peak torque than the current model. Increased fuel economy and longer maintenance intervals contribute to a reduced cost of operation.



EPFC System(Electric Positive Flow Control)

Smart Power mode reduces fuel consumption by adjusting the engine speed in heavy load work like digging. The key point of this function is not only saving fuel with same performance as Power mode but also making good balance between traction force and breakout force.



Environmentally friendly fuel efficiency

Attachment Flow Control

Option

The HW A Series optimizes attachments for effective flow rate setting depending on attachments (ten breaker types and ten crusher types), enabling various operations matching the site environments.



ECO Gauge

The operator can easily check the fuel consumption status from the ECO GAUGE in the cluster. Hourly and daily based fuel consumption can be checked in the detailed menu as well.

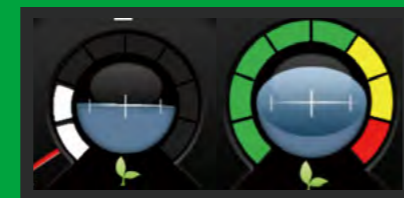

Enlarged Air Inlet with Grill Cover

Enlarged vent hole of the air inlet side cover and fine net grill to prevent penetration of foreign materials further improve durability.

Cycle Time Improvement

The HW A Series provides higher productivity on the site by faster operation: it loads trucks up to 2% faster than the 9 Series.

THE BEST PRODUCTIVITY AND FUEL EFFICIENCY

HW A Series is equipped with eco-friendly, high-performance engines that meet the EU Stage V emission requirements.

More Fuel-efficiency

Faster Leveling **11%**

Truck Loading **15%**



* Photo may include optional equipment.

ULTIMATE DURABILITY

The true value of HW A Series lies in its durability. The robust upper and lower frame structure can endure external shock and heavy work loads. Attachment performance has been proven through rigorous field testing. No matter how tough the working environment is, you can always rely on the HYUNDAI Excavator A Series.



* Photo may include optional equipment.



Hi-grade (High-pressure) Hoses

The HW A Series uses high-pressure hoses with improved heat and pressure resistance, greatly increasing the durability of the equipment.

Improved Outrigger Option

The outrigger legs have been lengthened. The outriggers have been lengthened, making the width of the equipment wider, which improves stability. And the covers of the outrigger cylinders have been reinforced.



New Counterweight Design NEW

The counterweight of the upgraded HW210A has a new design called the Tiger Eye design. It gives a strong and stylish impression. The new rear LED lamp's turn signal is a turntable type. The rear camera and working light are built into the CWT to avoid collisions.



Reinforced Pins, Bushings and Polymer Shims

The HW A series improves lubricity of connecting parts between the equipment and attachments. Gaps with attachments are minimized by wear-resistant long-life pins, bushes, and polymer shims, supporting the highest performance with invariable durability.

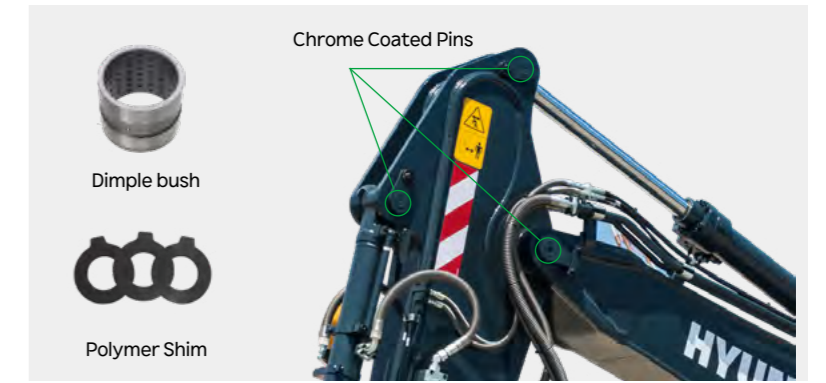

Proportional Joysticks and Pedal Control **Option**

Attachments can be controlled by proportional switch on the joystick or pedal for the attachments.



Swing Lock System **Option**

Swing lock system is provided to maintain stability when swing movement needs to be limited, improving operating speed and productivity.

Fine Swing Control **Option**

This option enables fine swing movement at the start and stop of operation.

Proportional Auxiliary Hydraulic Lines **Option**

Proportional control switch with better speed control helps operators to enlarge the operation convenience whenever they do time-consuming work. And this function can be switched with pedal valve in cluster setting menu. Newly added detent function allows an operator to continue using 2 way piping flow even if the operator does not keep pressing proportional control switch.



Automatic digging brake **Option**

While mark on this option sign on cluster, the brake operates without pushing brake pedal.



Joystick steering **Option**

While mark on this option sign on cluster, the joystick like the steering wheel can control wheels.



Dual mirror **NEW**

A dual mirror is provided on the left side of the cabin. It consists of two mirrors, each of which provides a wider viewing angle. The driver can see to the left with the main mirror and down with the auxiliary mirror.



A&C Type USB **NEW**

For convenient charging of mobile phones and other electronic devices, A type and C type USB are provided on the right console.

FNR and Ram Lock Switch on Joystick

It is easy to control FNR and Ram Lock, because the switches for the options are located on joystick.

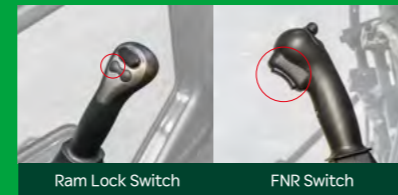

Bucket-Clamshell Adaptation **Option**

To use the clamshell grab, various parts including the 3 way valve are installed on equipment. The equipment can use the clamshell grab instead of the bucket.

Jog Dial Module

The integrated jog dial module applies to the accelerator, remote air conditioner controller and operation of the cluster, allowing convenient operation. In the event of failure of the jog dial module, the emergency mode is activated on the cluster to ensure fail-safe function.



USB-MP3-Handsfree Audio System

Radio player, USB-based MP3 player, integrated Bluetooth hands-free feature, and built-in microphone allow convenient phone calls while in work and in transit. The radio player was moved to the right side from the rear, allowing easier access.



* Photo may include optional equipment.



EASY CONTROL AND COMFORTABLE OPERATION

Many electronic functions are concentrated on the most convenient spot for operators to ensure work efficiency. The highly-advanced infotainment system, a product of HCEI's intensive information technology development, enables both productivity and comfort while working! The HW A Series is designed with the operator in mind.

THE ULTIMATE SAFE ENVIRONMENT

The true value of HW A Series lies in its safety. You can focus on your work with confidence with safety devices designed to take into account the nature of your work environment.



* Photo may include optional equipment.

HW210A with advanced technology ensures our safety on a construction site.

HW A Series excavators are products of Hce's spirit of initiative, creativity, and strong drive. HCE engineers, who are the best in the industry, have worked tirelessly to offer a zero-defect product. The new HW A Series reflects customers' needs in the field gleaned by thorough monitoring.

Auto Safety Lock

It prevents unintended operation. If operator unlock safety lever when RCV lever is pressed, excavator is not controlled by RCV lever.

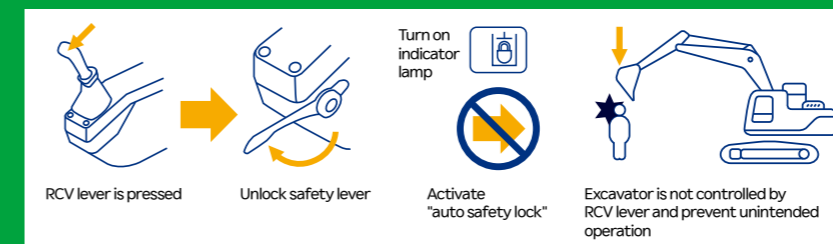

Half Bar Beacon Lamp **Option**

Instead of a rotating beacon lamp higher than the cabin, we provide beacon lamps at the four corners of the cabin. The lower height reduces the risk of hitting obstacles.

4 Lamps on cabin **NEW** **Option**

Quantity of lamp is changed from 2 to 4. Additional lamps provide bright visibility in night or dark places.

Over Swing Lock **NEW**

If you turn in one direction for more than 90 seconds, the turn will automatically stop. This is to allow you to force a stop in case the turn continues due to driver error or equipment failure. If you intentionally turn continuously, you can select it in the cluster.



SAVM (Smart Around View Monitoring) Camera System **Option** **NEW**

This model has SAVM camera system to secure field of vision for operators in all directions, thereby preventing accidents. Operators can easily check the workplace in the front and rear and to the right and left.

SAVM(Smart Around View Monitoring):

When a person appears on the screen, it recognizes the person and displays a warning sign. By sufficiently training the human model, it displays a warning sign on the screen when a person comes near. It can also recognize people while driving, such as when turning the equipment.



Built-in Camera **NEW**

The side cameras are built into the cowl, and the rear cameras are built into the counterweight. So the cameras are safe from external obstacles and the equipment looks neater.

Improvement Radar & 10" 2nd Monitor **NEW** **Option**

The improved radar has a wider detection angle. The detection angle has been changed from 100 ° to 180 °. Also, the second monitor that shows the camera and radar has been changed from 7" to 10". This will help the operator to be aware of the machine's surroundings.



Rear and Mirror View Camera **Option**

Option

Simple type mirror view with rear view camera option is available. This option helps the operator cover visual blind spot on the right side.



Cruise Control & Speed Limiter **Option**

Option

HW A Series has an option to keep the driving speed without accelerator pedal and an option to limit max speed for local speed regulations.

Seatbelt Warning Signal

If the seatbelt is not buckled when the ignition key is turned, an alarm is triggered in intervals along with a continuous visual alert. This emphasizes our priority for operator safety.

LED Front Lamp **NEW**

LED front lamps can provide bright visibility even in the dark places. The lamps are brighter, which helps you work or drive at night.



SERVICEABILITY AND TELEMATICS

IoT / ICT / AI-based digital technology. Creating a smart construction site. Maximizes connectivity, productivity, and safety for successful businesses.



*Photo may include optional equipment.

Hi MATE

Option

IT'S CONVENIENT, EASY AND VALUABLE

Hi MATE, Hyundai's newly developed remote management system, utilizes GPS-satellite technology to provide customers with the highest level of service and product support available. Hi MATE enables users to remotely evaluate machine performance, access diagnostic information, and verify machine locations at the touch of a button.

WHAT IS BENEFITS



Increase Productivity

It helps you operate machines in efficient. You can check the difference between total engine hours and actual working hours. See how productive your machines are and plan any required cost saving solutions. Hi MATE offers working information such as working / idling hours, fuel consumption and rate.



Convenient and Easy Monitoring

There is nothing much to do to monitor your machines. Just log on to the Hi MATE website or mobile application. Hi MATE allows you to watch your machines whenever and wherever you are.



Security

Protect your machines from theft or unauthorized usage with Hi MATE. If the machine moves out of the Geo-fence boundary, you will get alerts.

ECD(Engine Connected Diagnostics) Option

ECD will support the after sales technicians and dealers with a diagnostics report (via e-mail, mobile, app or Hi MATE) on the engine performance. This will help after sales technicians arrive on site with the necessary tools and parts to fix troubles in one visit. ECD is an integrated remote diagnostics service between Cummins cloud and Hi MATE cloud.

We are all connected

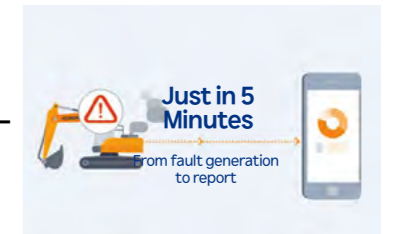

Mobile Fleet App Option

The new Mobile App is optimized to fleet management. It provides productivity, health insights based on telematics technology and enables fleet owner just focus on most wanted equipment in view of economical usage, utilization, fault codes and maintenance.

'Hi MATE Fleet Manager' App

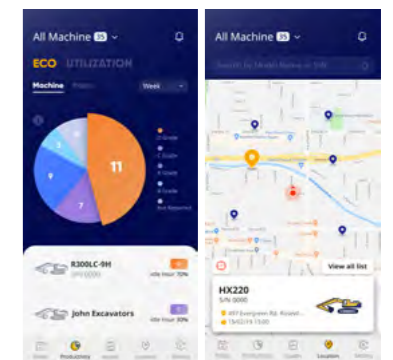

Easy Access to DEF/AdBlue® Supply System

The DEF/AdBlue® tank is installed inside the tool box and its inlet is remotely located for easy access and convenient supply. Warning of overfill is given by a red lamp signal.



2X Longer Lasting Filter

The length of product life period is improved from 500 hours to 1,000 hours. (when using CK-4 engine oil)

- Engine Oil Filter (to 800 hours)
- Engine Oil (to 800 hours)
- Pre-filter
- Fuel Filter

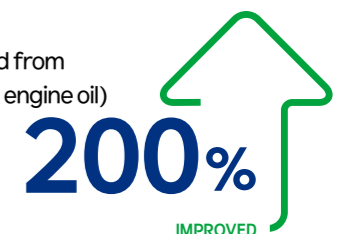

SPECIFICATIONS

ENGINE

Maker / Model	CUMMINS / B6.7
Type	6 cylinder, turbocharged, charge air cooled, electronic controlled diesel engine
Gross Power	129 kW (173 hp) at 2,200 rpm
Net Power	127 kW (170 hp) at 2,200 rpm
Max. Power	145 kW (195 hp) at 2,200 rpm
Peak Torque	881 N·m (650 lb·ft) at 1,300 rpm
Displacement	6,700 cc (409 cu in)

HYDRAULIC SYSTEM

MAIN PUMP	
Type	Piston pumps
Max. flow	2 X 208 lpm
Sub-pump for pilot circuit	Gear pump

Cross-sensing and fuel saving pump system

HYDRAULIC MOTORS

Travel	Two speed axial pistons motor with brake valve and parking brake
Swing	Axial piston motor with automatic brake

RELIEF VALVE SETTING

Implement circuits	350 kgf/cm ² (4,980 psi)
Travel	380 kgf/cm ² (5,400 psi)
Power boost (boom, arm, bucket)	380 kgf/cm ² (5,400 psi)
Swing circuit	265 kgf/cm ² (3,770 psi)
Pilot circuit	40 kgf/cm ² (570 psi)
Service valve	Installed

HYDRAULIC CYLINDERS

No. of cylinder bore X stroke	Boom: 2-120 x 1,275 mm
	Arm: 1-140 x 1,510 mm
	Bucket: 1-120 x 1,055 mm
	Dozer Blade: 2-125 x 252 mm
	Outrigger: 2-130 x 436 mm
	2-PCS boom: 2-120 x 1,080mm
	Adjust(boom): 1-170 x 720mm

* Hyundai Bio Hydraulic Oil (HBHO) available

DRIVES & BRAKES

4-wheel hydrostatic drive. Constant mesh, helical gear transmission provides 2 forward and reverse travel speeds.

Max. drawbar pull	11,713 kgf (25,822 lbf)
Travel speed	1st 9.5 km/h
	2nd 38.4 km/h
Gradeability	35° (70 %)

Service Brake :
 - Independent dual brake, front and rear axle full hydraulic power brake.
 - Spring released and hydraulic applied wet type multiple disc brake.
 Parking Brake :
 - Spring applied and hydraulic released wet disc brake type in transmission.

CONTROL

Pilot pressure operated joysticks and pedals with detachable lever provide almost effortless and fatigueless operation.

Pilot control	Two joysticks with one safety lever (LH): Swing and arm, (RH): Boom and bucket (ISO)
Engine throttle	Electric, Dial type
Lights	Two lights mounted on the boom, one under the battery box and one under the cabin

AXLE & WHEEL

Full floating front axle is supported by center pin for oscillation. It can be locked by oscillation lock cylinders. Rear axle is fixed on the lower chassis.

Tires	10.00-20-14PR, Dual(tube type)
(Optional)	10.00-20, Dual(solid type)
	10.00-20-16PR, Dual(tube type)

STEERING SYSTEM

Hydraulically actuated, orbitrol type steering system actuates on front wheels through the steering cylinders.

Min. turning radius	7,450 mm (24' 5")
---------------------	-------------------

SWING SYSTEM

Swing motor	Fixed displacement axial pistons motor
Swing reduction	Planetary gear reduction
Swing bearing lubrication	Grease-bathed
Swing brake	Multi wet disc
Swing speed	10.7 rpm

COOLANT & LUBRICANT CAPACITY

	liter	US gal	UK gal
Fuel tank	310.0	81.9	68.2
Engine coolant	40.0	10.6	8.8
Engine oil	24.4	6.4	5.4
Swing device	6.2	1.64	1.36
Axle	Front 14.6	3.9	3.2
	Rear 18.5	4.9	4.1
Transmission	2.5	0.7	0.5
Hydraulic system (including tank)	340.0	89.8	74.8
Hydraulic tank	165.0	43.6	36.3
DEF/AdBlue®	48.0	12.6	10.5

UNDERCARRIAGE

Reinforced box-section frame is all-welded, low-stress. Dozer blade and outriggers are available. A pin-on design.

Dozer blade	A very useful addition for leveling and back filling or clean-up work.
Outrigger	Indicated for max. operation stability when digging and lifting. Can be mounted on the front/or the rear.

OPERATING WEIGHT (APPROXIMATE)

Operating weight, including 5,650mm (18' 6") Mono boom, 5,400mm (17' 9") 2-Piece boom, 2,920mm (9' 7") arm, SAE heaped 0.80 m³ (1.05 yd³) backhoe bucket, lubricant, coolant, full fuel tank, hydraulic tank and the standard equipment.

OPERATING WEIGHT

	Mono boom	2-Piece boom
Undercarriage		
Front graplerest and Rear Dozer blade	21,180 kg (46,690 lb)	22,510 kg (49,630 lb)
Front outrigger and Rear blade	22,360 kg (49,290 lb)	23,690 kg (52,230 lb)
Front blade and Rear outrigger	22,510 kg (49,630 lb)	23,840 kg (52,560 lb)
Front and Rear outrigger	22,480 kg (49,560 lb)	23,810 kg (52,490 lb)
Front and Rear dozer	22,390 kg (49,360 lb)	23,720 kg (52,290 lb)

AIR CONDITIONING SYSTEM

The air condition system for the machine contains the fluorinated greenhouse gas with global warming potential of R134a. (Global Warming Potential : 1,430)
 The system hold 0.8 kg refrigerant consisting of a CO₂ equivalent 1.14kg metric tonne. For more information, Please refer to the manual.

DIMENSIONS & WORKING RANGE

MONO BOOM DIMENSIONS

5.65 m (18' 6") Mono boom, 2.4 m (7' 10"), 2.70 (8' 10") 2.92 (9' 7") Arm, Front outrigger and rear dozer blade.

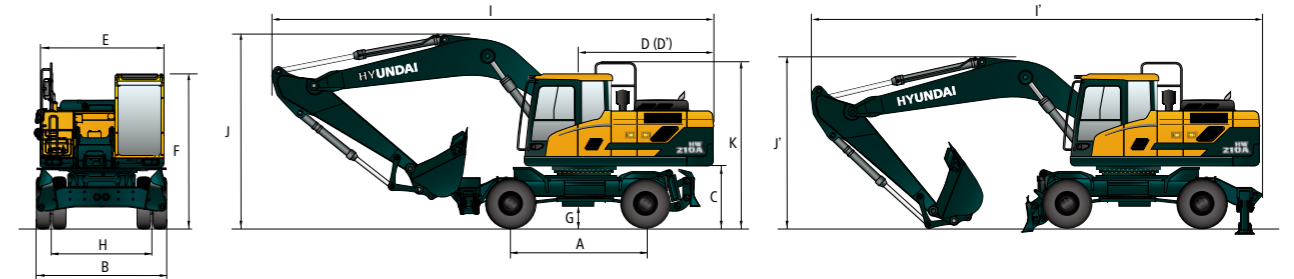

Unit : mm (ft-in)

A Wheel base	2,850 (9' 4")
B Overall width (STD / Wide axle)	2,530 (8' 4") / 2,750 (9' 0")
C Ground clearance of counterweight	1,295 (4' 3")
D Rear-end distance	2,733 (8' 12")
D' Rear-end swing radius	2,733 (8' 12")
E Upperstructure width	2,530 (8' 4")
F Overall height of cab	3,260 (10' 8")
G Min. ground clearance	353 (1' 2")
H Tread	1,914 (6' 3")
K Overall height of guardrail	3,330 (10' 11")

Boom length	5,650 (18' 6")
Arm length	2,400 (7' 10") / 2,700 (8' 10") / 2,920 (9' 7")
I Overall length (Traveling position)	9,590 (31' 6") / 9,540 (31' 4") / 9,380 (30' 9")
I' Overall length (Shipping position)	9,680 (31' 9") / 9,570 (31' 5") / 9,500 (31' 2")
J Overall height of boom (Traveling position)	3,720 (12' 2") / 3,650 (12' 0") / 4,020 (13' 2")
J' Overall height of boom (Shipping position)	3,350 (11' 0") / 3,240 (10' 8") / 3,150 (10' 4")

MONO BOOM WORKING RANGE

Unit : mm (ft-in)

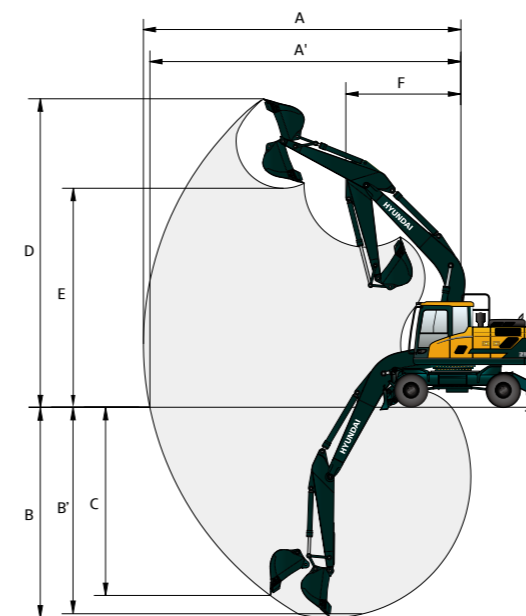

Boom length	5,650 (18' 6")
Arm length	2,400 (7' 10") / 2,700 (8' 10") / 2,920 (9' 7")
A Max. digging reach	9,480 (31' 1") / 9,760 (32' 0") / 9,970 (32' 9")
A' Max. digging reach on ground	9,270 (30' 5") / 9,550 (31' 4") / 9,770 (32' 1")
B Max. digging depth	5,860 (19' 3") / 6,210 (20' 4") / 6,430 (21' 1")
B' Max. digging depth (8' level)	5,660 (18' 7") / 5,980 (19' 7") / 6,210 (20' 4")
C Max. vertical wall digging depth	5,510 (18' 1") / 5,830 (19' 2") / 6,110 (20' 1")
D Max. digging height	9,710 (31' 10") / 9,870 (32' 5") / 10,020 (32' 10")
E Max. dumping height	6,860 (22' 6") / 7,010 (23' 0") / 7,160 (23' 6")
F Min. swing radius	3,520 (11' 7") / 3,490 (11' 5") / 3,460 (11' 4")

DIMENSIONS & WORKING RANGE

2-PIECE BOOM DIMENSIONS

5.4 m (17' 9") 2-Piece boom, 2.40 m (7' 10"), 2.70 m (8' 10"), 2.92 m (9' 7") Arm, Rear dozer

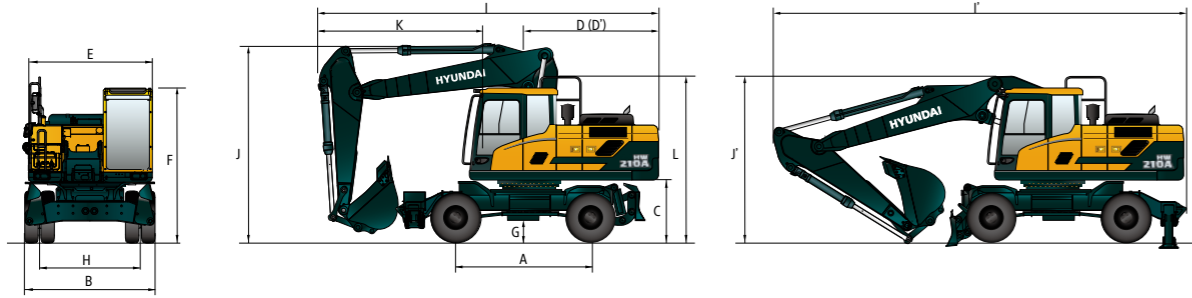

A	Wheel base	2,850 (9' 4")
B	Overall width (STD / Wide axle)	2,530 (8' 4") / 2,750 (9' 0")
C	Ground clearance of counterweight	1,295 (4' 3")
D	Rear-end distance	2,733 (8' 12")
D'	Rear-end swing radius	2,740 (8' 12")
E	Upperstructure width	2,530 (8' 4")
F	Overall height of cab	3,260 (10' 8")
G	Min. ground clearance	347 (1' 2")
H	Tread	1,914 (6' 3")
L	Overall height of guardrail	3,330 (10' 11")

		Unit : mm (ft-in)		
	Boom length	5,400 (17' 9")		
	Arm length	2,400 (7' 10")	2,700 (8' 10")	2,920 (9' 7")
I	Overall length (Traveling position)	7,090 (23' 3")	7,060 (23' 2")	6,980 (22' 11")
I'	Overall length (Shipping position)	9,240 (30' 4")	9,250 (30' 4")	9,230 (30' 3")
J	Overall height of boom (Traveling position)	3,990 (13' 1")	3,990 (13' 1")	3,990 (13' 1")
J'	Overall height of boom (Shipping position)	3,170 (10' 5")	3,150 (10' 4")	3,180 (10' 5")
K	End of attachment to steering wheel	3,610 (11' 1")	3,580 (11' 9")	3,500 (11' 6")

2-PIECE BOOM WORKING RANGE

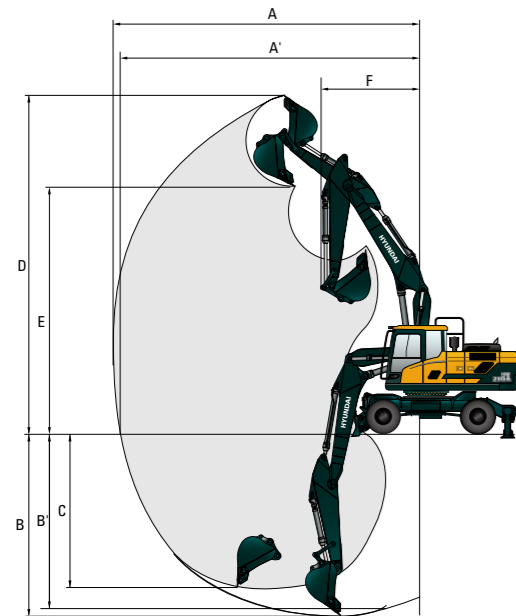

		Unit : mm (ft-in)		
	Boom length	5,400 (17' 9")		
	Arm length	2,400 (7' 10")	2,700 (8' 10")	2,920 (9' 7")
A	Max. digging reach	9,310 (30' 7")	9,600 (31' 6")	9,810 (32' 2")
A'	Max. digging reach on ground	9,100 (29' 10")	9,400 (30' 10")	9,610 (31' 6")
B	Max. digging depth	5,570 (18' 3")	5,870 (19' 3")	6,090 (20' 0")
B'	Max. digging depth (8' level)	5,470 (17' 11")	5,770 (18' 11")	6,000 (19' 8")
C	Max. vertical wall digging depth	4,630 (15' 2")	4,580 (15' 0")	4,730 (15' 6")
D	Max. digging height	10,300 (33' 10")	10,520 (34' 6")	10,690 (35' 1")
E	Max. dumping height	7,370 (24' 2")	7,590 (24' 11")	7,750 (25' 5")
F	Min. swing radius	3,030 (9' 11")	2,870 (9' 5")	2,860 (9' 5")

LIFTING CAPACITY

Rating over-front Rating over-side or 360 degree

MONO BOOM

5.65 m (18' 6") Mono boom, 2.40 m (7' 10") arm and 4 outrigger up.

Lift point height m (ft)	Lift radius								At max. reach		
	3.0 m (9.8 ft)		4.5 m (14.8 ft)		6.0 m (19.7 ft)		7.5 m (24.6 ft)		Capacity	Reach	
											m (ft)
7.5 m (24.6 ft)	kg								*4,820	4,660	5.72 (18.8)
	lb								*10,630	10,270	
6.0 m (19.7 ft)	kg			*5,520	4,330				*4,400	3,400	6.89 (22.6)
	lb			*12,170	9,550				*9,700	7,500	
4.5 m (14.8 ft)	kg		*7,190	6,450	*5,960	4,170	4,330	2,900	4,240	2,840	7.59 (24.9)
	lb		*15,850	14,220	*13,140	9,190	9,550	6,390	9,350	6,260	
3.0 m (9.8 ft)	kg		*8,800	5,900	5,980	3,940	4,240	2,820	3,870	2,570	7.94 (26.1)
	lb		*19,400	13,010	13,180	8,690	9,350	6,220	8,530	5,670	
1.5 m (4.9 ft)	kg		8,890	5,490	5,750	3,730	4,140	2,730	3,760	2,480	8.00 (26.2)
	lb		19,600	12,100	12,680	8,220	9,130	6,020	8,290	5,470	
Ground	kg		8,680	5,310	5,600	3,600	4,070	2,670	3,890	2,550	7.76 (25.5)
Line	lb		19,140	11,710	12,350	7,940	8,970	5,890	8,580	5,620	
-1.5 m (-4.9 ft)	kg	*11,990	9,990	8,660	5,300	5,570	3,570		4,320	2,820	7.21 (23.7)
	lb	*26,430	22,020	19,090	11,680	12,280	7,870		9,520	6,220	
-3.0 m (-9.8 ft)	kg	*11,220	10,210	*8,410	5,410	5,680	3,660		5,380	3,490	6.25 (20.5)
	lb	*24,740	22,510	*18,540	11,930	12,520	8,070		11,860	7,690	

5.65 m (18' 6") Mono boom, 2.40 m (7' 10") arm, outrigger and dozer blade up.

Lift point height m (ft)	Lift radius								At max. reach		
	3.0 m (9.8 ft)		4.5 m (14.8 ft)		6.0 m (19.7 ft)		7.5 m (24.6 ft)		Capacity	Reach	
											m (ft)
7.5 m (24.6 ft)	kg								*4,820	4,670	5.72 (18.8)
	lb								*10,630	10,300	
6.0 m (19.7 ft)	kg			*5,520	4,330				*4,400	3,410	6.89 (22.6)
	lb			*12,170	9,550				*9,700	7,520	
4.5 m (14.8 ft)	kg		*7,190	6,460	*5,960	4,180	4,330	2,910	4,240	2,850	7.59 (24.9)
	lb		*15,850	14,240	*13,140	9,220	9,550	6,420	9,350	6,280	
3.0 m (9.8 ft)	kg		*8,800	5,920	5,980	3,950	4,250	2,830	3,870	2,580	7.94 (26.1)
	lb		*19,400	13,050	13,180	8,710	9,370	6,240	8,530	5,690	
1.5 m (4.9 ft)	kg		8,890	5,500	5,750	3,730	4,140	2,730	3,760	2,480	8.00 (26.2)
	lb		19,600	12,130	12,680	8,220	9,130	6,020	8,290	5,470	
Ground	kg		8,680	5,320	5,600	3,600	4,070	2,670	3,890	2,550	7.76 (25.5)
Line	lb		19,140	11,730	12,350	7,940	8,970	5,890	8,580	5,620	
-1.5 m (-4.9 ft)	kg	*11,990	10,010	8,660	5,310	5,570	3,570		4,320	2,830	7.21 (23.7)
	lb	*26,430	22,070	19,090	11,710	12,280	7,870		9,520	6,240	
-3.0 m (-9.8 ft)	kg	*11,220	10,230	*8,410	5,420	5,680	3,670		5,380	3,500	6.25 (20.5)
	lb	*24,740	22,550	*18,540	11,950	12,520	8,090		11,860	7,720	

- Lifting capacity are based on ISO 10567.
- Lifting capacity does not exceed 75% of tipping load with the machine on firm, level ground or 87% of full hydraulic capacity.
- The Lift-point is bucket pivot mounting pin on the arm (without bucket mass).
- (*) indicates load limited by hydraulic capacity.

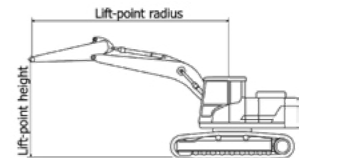

LIFTING CAPACITY

Rating over-front Rating over-side or 360 degree

MONO BOOM

5.65 m (18' 6") Mono boom, 2.40 m (7' 10") arm and 4 outrigger down.

Lift point height m (ft)	Lift radius								At max. reach		
	3.0 m (9.8 ft)		4.5 m (14.8 ft)		6.0 m (19.7 ft)		7.5 m (24.6 ft)		Capacity	Reach	
7.5 m (24.6 ft)	kg								*4,820	*4,820	5.72
	lb								*10,630	*10,630	(18.8)
6.0 m (19.7 ft)	kg			*5,520	*5,520				*4,400	*4,400	6.89
	lb			*12,170	*12,170				*9,700	*9,700	(22.6)
4.5 m (14.8 ft)	kg		*7,190	*7,190	*5,960	*5,960	*5,130	4,570	*4,300	*4,300	7.59
	lb		*15,850	*15,850	*13,140	*13,140	*11,310	10,080	*9,480	*9,480	(24.9)
3.0 m (9.8 ft)	kg		*8,800	*8,800	*6,640	6,310	*5,630	4,490	*4,390	4,100	7.94
	lb		*19,400	*19,400	*14,640	13,910	*12,410	9,900	*9,680	9,040	(26.1)
1.5 m (4.9 ft)	kg		*10,000	9,380	*7,260	6,070	*5,870	4,380	*4,680	3,980	8.00
	lb		*22,050	20,680	*16,010	13,380	*12,940	9,660	*10,320	8,770	(26.2)
Ground Line	kg		*10,280	9,170	*7,540	5,920	*5,900	4,320	*5,240	4,120	7.76
	lb		*22,660	20,220	*16,620	13,050	*13,010	9,520	*11,550	9,080	(25.5)
-1.5 m (-4.9 ft)	kg	*11,990	*11,990	*9,780	9,160	*7,290	5,890		*5,710	4,570	7.21
	lb	*26,430	*26,430	*21,560	20,190	*16,070	12,990		*12,590	10,080	(23.7)
-3.0 m (-9.8 ft)	kg	*11,220	*11,220	*8,410	*8,410	*6,070	6,000		*5,610	*5,610	6.25
	lb	*24,740	*24,740	*18,540	*18,540	*13,380	13,230		*12,370	*12,370	(20.5)

5.65 m (18' 6") Mono boom, 2.40 m (7' 10") arm, outrigger and dozer blade down.

Lift point height m (ft)	Lift radius								At max. reach		
	3.0 m (9.8 ft)		4.5 m (14.8 ft)		6.0 m (19.7 ft)		7.5 m (24.6 ft)		Capacity	Reach	
7.5 m (24.6 ft)	kg								*4,820	*4,820	5.72
	lb								*10,630	*10,630	(18.8)
6.0 m (19.7 ft)	kg			*5,520	*5,520				*4,400	*4,400	6.89
	lb			*12,170	*12,170				*9,700	*9,700	(22.6)
4.5 m (14.8 ft)	kg		*7,190	*7,190	*5,960	5,550	*5,130	3,880	*4,300	3,800	7.59
	lb		*15,850	*15,850	*13,140	12,240	*11,310	8,550	*9,480	8,380	(24.9)
3.0 m (9.8 ft)	kg		*8,800	8,140	*6,640	5,310	*5,630	3,790	*4,390	3,460	7.94
	lb		*19,400	17,950	*14,640	11,710	*12,410	8,360	*9,680	7,630	(26.1)
1.5 m (4.9 ft)	kg		*10,000	7,680	*7,260	5,080	*5,870	3,690	*4,680	3,360	8.00
	lb		*22,050	16,930	*16,010	11,200	*12,940	8,140	*10,320	7,410	(26.2)
Ground Line	kg		*10,280	7,480	*7,540	4,940	*5,900	3,630	*5,240	3,460	7.76
	lb		*22,660	16,490	*16,620	10,890	*13,010	8,000	*11,550	7,630	(25.5)
-1.5 m (-4.9 ft)	kg	*11,990	*11,990	*9,780	7,470	*7,290	4,910		*5,710	3,840	7.21
	lb	*26,430	*26,430	*21,560	16,470	*16,070	10,820		*12,590	8,470	(23.7)
-3.0 m (-9.8 ft)	kg	*11,220	*11,220	*8,410	7,600	*6,070	5,010		*5,610	4,760	6.25
	lb	*24,740	*24,740	*18,540	16,760	*13,380	11,050		*12,370	10,490	(20.5)

- Lifting capacity are based on ISO 10567.
- Lifting capacity does not exceed 75% of tipping load with the machine on firm, level ground or 87% of full hydraulic capacity.
- The Lift-point is bucket pivot mounting pin on the arm (without bucket mass).
- (*) indicates load limited by hydraulic capacity.

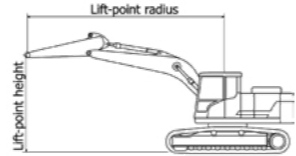

Rating over-front Rating over-side or 360 degree

MONO BOOM

5.65 m (18' 6") Mono boom, 2.40 m (7' 10") arm, dozer blade and outrigger up.

Lift point height m (ft)	Lift radius								At max. reach		
	3.0 m (9.8 ft)		4.5 m (14.8 ft)		6.0 m (19.7 ft)		7.5 m (24.6 ft)		Capacity	Reach	
7.5 m (24.6 ft)	kg								*4,820	4,740	5.72
	lb								*10,630	10,450	(18.8)
6.0 m (19.7 ft)	kg			*5,520	4,400				*4,400	3,460	6.89
	lb			*12,170	9,700				*9,700	7,630	(22.6)
4.5 m (14.8 ft)	kg		*7,190	6,560	*5,960	4,240	4,350	2,960	*4,260	2,900	7.59
	lb		*15,850	14,460	*13,140	9,350	9,590	6,530	9,390	6,390	(24.9)
3.0 m (9.8 ft)	kg		*8,800	6,010	6,000	4,010	4,260	2,880	3,890	2,620	7.94
	lb		*19,400	13,250	13,230	8,840	9,390	6,350	8,580	5,780	(26.1)
1.5 m (4.9 ft)	kg		8,910	5,590	5,770	3,800	4,150	2,780	3,780	2,530	8.00
	lb		19,640	12,320	12,720	8,380	9,150	6,130	8,330	5,580	(26.2)
Ground Line	kg		8,710	5,410	5,620	3,670	4,090	2,720	3,900	2,600	7.76
	lb		19,200	11,930	12,390	8,090	9,020	6,000	8,600	5,730	(25.5)
-1.5 m (-4.9 ft)	kg	*11,990	10,180	8,690	5,400	5,590	3,640		4,330	2,880	7.21
	lb	*26,430	22,440	19,160	11,900	12,320	8,020		9,550	6,350	(23.7)
-3.0 m (-9.8 ft)	kg	*11,220	10,390	*8,410	5,520	5,700	3,740		5,400	3,560	6.25
	lb	*24,740	22,910	*18,540	12,170	12,570	8,250		11,900	7,850	(20.5)

5.65 m (18' 6") Mono boom, 2.40 m (7' 10") arm, dozer blade and outrigger down.

Lift point height m (ft)	Lift radius								At max. reach		
	3.0 m (9.8 ft)		4.5 m (14.8 ft)		6.0 m (19.7 ft)		7.5 m (24.6 ft)		Capacity	Reach	
7.5 m (24.6 ft)	kg								*4,820	*4,820	5.72
	lb								*10,630	*10,630	(18.8)
6.0 m (19.7 ft)	kg			*5,520	*5,520				*4,400	*4,400	6.89
	lb			*12,170	*12,170				*9,700	*9,700	(22.6)
4.5 m (14.8 ft)	kg		*7,190	*7,190	*5,960	5,830	*5,130	4,080	*4,300	4,000	7.59
	lb		*15,850	*15,850	*13,140	12,850	*11,310	8,990	*9,480	8,820	(24.9)
3.0 m (9.8 ft)	kg		*8,800	8,590	*6,640	5,580	*5,630	3,990	*4,390	3,650	7.94
	lb		*19,400	18,940	*14,640	12,300	*12,410	8,800	*9,680	8,050	(26.1)
1.5 m (4.9 ft)	kg		*10,000	8,130	*7,260	5,360	*5,870	3,890	*4,680	3,540	8.00
	lb		*22,050	17,920	*16,010	11,820	*12,940	8,580	*10,320	7,800	(26.2)
Ground Line	kg		*10,280	7,930	*7,540	5,210	*5,900	3,830	*5,240	3,650	7.76
	lb		*22,660	17,480	*16,620	11,490	*13,010	8,440	*11,550	8,050	(25.5)
-1.5 m (-4.9 ft)	kg	*11,990	*11,990	*9,780	7,920	*7,290	5,180		*5,710	4,050	7.21
	lb	*26,430	*26,430	*21,560	17,460	*16,070	11,420		*12,590	8,930	(23.7)
-3.0 m (-9.8 ft)	kg	*11,220	*11,220	*8,410	8,050	*6,070	5,290		*5,610	5,020	6.25
	lb	*24,740	*24,740	*18,540	17,750	*13,380	11,660		*12,370	11,070	(20.5)

- Lifting capacity are based on ISO 10567.
- Lifting capacity does not exceed 75% of tipping load with the machine on firm, level ground or 87% of full hydraulic capacity.
- The Lift-point is bucket pivot mounting pin on the arm (without bucket mass).
- (*) indicates load limited by hydraulic capacity.

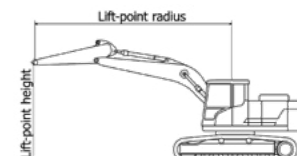











LIFTING CAPACITY











 Rating over-front  Rating over-side or 360 degree

MONO BOOM

5.65 m (18' 6") Mono boom, 2.70m (8' 10") arm and 4 outrigger up.

Lift point height m (ft)	Lift radius								At max. reach			
	3.0 m (9.8 ft)		4.5 m (14.8 ft)		6.0 m (19.7 ft)		7.5 m (24.6 ft)		Capacity		m (ft)	
												
7.5 m (24.6 ft)	kg					*4,180	*4,180			*3,620	*3,620	6.10 (20.0)
	lb					*9,220	*9,220			*7,980	*7,980	
6.0 m (19.7 ft)	kg					*5,270	4,390			*3,330	3200	7.21 (23.6)
	lb					*11,620	9,680			*7,340	7050	
4.5 m (14.8 ft)	kg		*6,840	6,570	*5,750	4,230	4,390	2,960		*3,260	2710	7.88 (25.8)
	lb		*15,080	14,480	*12,680	9,330	9,680	6,530		*7,190	5970	
3.0 m (9.8 ft)	kg		*8,500	6,030	6,050	4,000	4,290	2,860		*3,330	2460	8.22 (27.0)
	lb		*18,740	13,290	13,340	8,820	9,460	6,310		*7,340	5420	
1.5 m (4.9 ft)	kg		8,990	5,580	5,800	3,770	4,170	2,750		*3,540	2380	8.27 (27.1)
	lb		19,820	12,300	12,790	8,310	9,190	6,060		*7,800	5250	
Ground Line	kg	*6,270	*6,270	8,730	5,360	5,630	3,630	4,090	2,680	3,700	2440	8.05 (26.4)
	lb	*13,820	*13,820	19,250	11,820	12,410	8,000	9,020	5,910	8,160	5380	
-1.5 m (-4.9 ft)	kg	*11,690	9,970	8,680	5,320	5,580	3,580	4,080	2,680	4,080	2670	7.51 (24.6)
	lb	*25,770	21,980	19,140	11,730	12,300	7,890	8,990	5,910	8,990	5890	
-3.0 m (-9.8 ft)	kg	*12,050	10,160	8,780	5,400	5,640	3,640			4,960	3240	6.59 (21.6)
	lb	*26,570	22,400	19,360	11,900	12,430	8,020			10,930	7140	
-4.5 m (-14.8 ft)	kg		*6,090	5,660						*5,010	4810	5.08 (16.7)
	lb		*13,430	12,480						*11,050	10600	

5.65 m (18' 6") Mono boom, 2.70m (8' 10") arm, outrigger and dozer blade up.

Lift point height m (ft)	Lift radius								At max. reach			
	3.0 m (9.8 ft)		4.5 m (14.8 ft)		6.0 m (19.7 ft)		7.5 m (24.6 ft)		Capacity		Reach m (ft)	
												
7.5 m (24.6 ft)	kg					*4,180	*4,180			*3,620	*3,620	6.10 (20.0)
	lb					*9,220	*9,220			*7,980	*7,980	
6.0 m (19.7 ft)	kg					*5,270	4,400			*3,330	3,210	7.21 (23.6)
	lb					*11,620	9,700			*7,340	7,080	
4.5 m (14.8 ft)	kg		*6,840	6,580	*5,750	4,240	4,390	2,960		*3,260	2,710	7.88 (25.8)
	lb		*15,080	14,510	*12,680	9,350	9,680	6,530		*7,190	5,970	
3.0 m (9.8 ft)	kg		*8,500	6,040	6,050	4,000	4,290	2,870		*3,330	2,470	8.22 (27.0)
	lb		*18,740	13,320	13,340	8,820	9,460	6,330		*7,340	5,450	
1.5 m (4.9 ft)	kg		8,990	5,590	5,800	3,780	4,170	2,760		*3,540	2,380	8.27 (27.1)
	lb		19,820	12,320	12,790	8,330	9,190	6,080		*7,800	5,250	
Ground Line	kg	*6,270	*6,270	8,730	5,370	5,630	3,630	4,090	2,680	3,700	2,440	8.05 (26.4)
	lb	*13,820	*13,820	19,250	11,840	12,410	8,000	9,020	5,910	8,160	5,380	
-1.5 m (-4.9 ft)	kg	*11,690	9,990	8,680	5,330	5,580	3,580	4,080	2,680	4,080	2,680	7.51 (24.6)
	lb	*25,770	22,020	19,140	11,750	12,300	7,890	8,990	5,910	8,990	5,910	
-3.0 m (-9.8 ft)	kg	*12,050	10,180	8,780	5,410	5,640	3,640			4,960	3,240	6.59 (21.6)
	lb	*26,570	22,440	19,360	11,930	12,430	8,020			10,930	7,140	
-4.5 m (-14.8 ft)	kg		*6,090	5,670						*5,010	4,820	5.08 (16.7)
	lb		*13,430	12,500						*11,050	10,630	



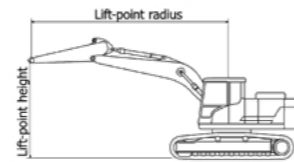







- Lifting capacity are based on ISO 10567.
- Lifting capacity does not exceed 75% of tipping load with the machine on firm, level ground or 87% of full hydraulic capacity.
- The Lift-point is bucket pivot mounting pin on the arm (without bucket mass).
- (*) indicates load limited by hydraulic capacity.













 Rating over-front  Rating over-side or 360 degree

MONO BOOM

5.65 m (18' 6") Mono boom, 2.70m (8' 10") arm and 4 outrigger down.

Lift point height m (ft)	Lift radius								At max. reach			
	3.0 m (9.8 ft)		4.5 m (14.8 ft)		6.0 m (19.7 ft)		7.5 m (24.6 ft)		Capacity		Reach m (ft)	
												
7.5 m (24.6 ft)	kg					*4,180	*4,180			*3,620	*3,620	6.10 (20.0)
	lb					*9,220	*9,220			*7,980	*7,980	
6.0 m (19.7 ft)	kg					*5,270	*5,270			*3,330	*3,330	7.21 (23.6)
	lb					*11,620	*11,620			*7,340	*7,340	
4.5 m (14.8 ft)	kg		*6,840	*6,840	*5,750	*5,750	*5,240	4,630		*3,260	*3,260	7.88 (25.8)
	lb		*15,080	*15,080	*12,680	*12,680	*11,550	10,210		*7,190	*7,190	
3.0 m (9.8 ft)	kg		*8,500	*8,500	*6,480	6,370	*5,510	4,530		*3,330	*3,330	8.22 (27.0)
	lb		*18,740	*18,740	*14,290	14,040	*12,150	9,990		*7,340	*7,340	
1.5 m (4.9 ft)	kg		*9,840	9,490	*7,170	6,120	*5,820	4,410		*3,540	*3,540	8.27 (27.1)
	lb		*21,690	20,920	*15,810	13,490	*12,830	9,720		*7,800	*7,800	
Ground Line	kg	*6,270	*6,270	*10,320	9,230	*7,540	5,960	*5,940	4,330	*3,950	3,920	8.05 (26.4)
	lb	*13,820	*13,820	*22,750	20,350	*16,620	13,140	*13,100	9,550	*8,710	8,640	
-1.5 m (-4.9 ft)	kg	*11,690	*11,690	*9,980	9,180	*7,410	5,900	*4,870	4,320	*4,700	4,320	7.51 (24.6)
	lb	*25,770	*25,770	*22,000	20,240	*16,340	13,010	*10,740	9,520	*10,360	9,520	
-3.0 m (-9.8 ft)	kg	*12,050	*12,050	*8,810	*8,810	*6,470	5,970			*5,530	5,250	6.59 (21.6)
	lb	*26,570	*26,570	*19,420	*19,420	*14,260	13,160			*12,190	11,570	
-4.5 m (-14.8 ft)	kg		*6,090	*6,090						*5,010	*5,010	5.08 (16.7)
	lb		*13,430	*13,430						*11,050	*11,050	

5.65 m (18' 6") Mono boom, 2.70m (8' 10") arm, outrigger and dozer blade down.











Lift point height m (ft)	Lift radius								At max. reach			
	3.0 m (9.8 ft)		4.5 m (14.8 ft)		6.0 m (19.7 ft)		7.5 m (24.6 ft)		Capacity		Reach m (ft)	
												
7.5 m (24.6 ft)	kg					*4,180	*4,180			*3,620	*3,620	6.10 (20.0)
	lb					*9,220	*9,220			*7,980	*7,980	
6.0 m (19.7 ft)	kg					*5,270	*5,270			*3,330	*3,330	7.21 (23.6)
	lb					*11,620	*11,620			*7,340	*7,340	
4.5 m (14.8 ft)	kg		*6,840	*6,40	*5,750	5,620	*5,240	3,930		*3,260	*3,260	7.88 (25.8)
	lb		*15,080	*15,080	*12,680	12,390	*11,550	8,660		*7,190	*7,190	
3.0 m (9.8 ft)	kg		*8,500	8,270	*6,480	5,370	*5,510	3,830		*3,330	3,320	8.22 (27.0)
	lb		*18,740	18,230	*14,290	11,840	*12,150	8,440		*7,340	7,320	
1.5 m (4.9 ft)	kg		*9,840	7,780	*7,170	5,130	*5,820	3,720		*3,540	3,220	8.27 (27.1)
	lb		*21,690	17,150	*15,810	11,310	*12,830	8,200		*7,800	7,100	
Ground Line	kg	*6,270	*6,270	*10,320	7,540	*7,540	4,970	*5,940	3,640	*3,950	3,310	8.05 (26.4)
	lb	*13,820	*13,820	*22,750	16,620	*16,620	10,960	*13,100	8,020	*8,710	7,300	
-1.5 m (-4.9 ft)	kg	*11,690	*11,690	*9,980	7,490	*7,410	4,920	*4,870	3,640	*4,700	3,630	7.51 (24.6)
	lb	*25,770	*25,770	*22,000	16,510	*16,340	10,850	*10,740	8,020	*10,360	8,000	
-3.0 m (-9.8 ft)	kg	*12,050	*12,050	*8,810	7,580	*6,470	4,980			*5,530	4,400	6.59 (21.6)
	lb	*26,570	*26,570	*19,420	16,710	*14,260	10,980			*12,190	9,700	
-4.5 m (-14.8 ft)	kg		*6,090	*6,090								

LIFTING CAPACITY











 Rating over-front  Rating over-side or 360 degree

MONO BOOM

5.65 m (18' 6") Mono boom, 2.70m (8' 10") arm, dozer blade and outrigger up.

Lift point height m (ft)	Lift radius								At max. reach			
	3.0 m (9.8 ft)		4.5 m (14.8 ft)		6.0 m (19.7 ft)		7.5 m (24.6 ft)		Capacity	Reach		
											m (ft)	
7.5 m (24.6 ft)	kg				*4,180	*4,180			*3,620	*3,620	6.10	
	lb				*9,220	*9,220			*7,980	*7,980	(20.0)	
6.0 m (19.7 ft)	kg				*5,270	4,470			*3,330	3,260	7.21	
	lb				*11,620	9,850			*7,340	7,190	(23.6)	
4.5 m (14.8 ft)	kg		*6,840	6,670	*5,750	4,300	4,400	3,010	*3,260	2,760	7.88	
	lb		*15,080	14,700	*12,680	9,480	9,700	6,640	*7,190	6,080	(25.8)	
3.0 m (9.8 ft)	kg		*8,500	6,130	6,070	4,070	4,300	2,920	*3,330	2,510	8.22	
	lb		*18,740	13,510	13,380	8,970	9,480	6,440	*7,340	5,530	(27.0)	
1.5 m (4.9 ft)	kg		9,020	5,680	5,820	3,850	4,180	2,810	*3,540	2,430	8.27	
	lb		19,890	12,520	12,830	8,490	9,220	6,190	*7,800	5,360	(27.1)	
Ground Line	kg	*6,270	*6,270	8,760	5,460	5,650	3,700	4,100	2,730	3,720	2,490	8.05
	lb	*13,820	*13,820	19,310	12,040	12,460	8,160	9,040	6,020	8,200	5,490	(26.4)
-1.5 m (-4.9 ft)	kg	*11,690	10,150	8,710	5,420	5,590	3,650	4,100	2,730	4,090	2,730	7.51
	lb	*25,770	22,380	19,200	11,950	12,320	8,050	9,040	6,020	9,020	6,020	(24.6)
-3.0 m (-9.8 ft)	kg	*12,050	10,350	8,810	5,500	5,660	3,710			4,980	3,300	6.59
	lb	*26,570	22,820	19,420	12,130	12,480	8,180			10,980	7,280	(21.6)
-4.5 m (-14.8 ft)	kg		*6,090	5,760						*5,010	4,900	5.08
	lb		*13,430	12,700						*11,050	10,800	(16.7)

5.65 m (18' 6") Mono boom, 2.70m (8' 10") arm, dozer blade and outrigger down.

Lift point height m (ft)	Lift radius								At max. reach			
	3.0 m (9.8 ft)		4.5 m (14.8 ft)		6.0 m (19.7 ft)		7.5 m (24.6 ft)		Capacity	Reach		
											m (ft)	
7.5 m (24.6 ft)	kg				*4,180	*4,180			*3,620	*3,620	6.10	
	lb				*9,220	*9,220			*7,980	*7,980	(20.0)	
6.0 m (19.7 ft)	kg				*5,270	*5,270			*3,330	*3,330	7.21	
	lb				*11,620	*11,620			*7,340	*7,340	(23.6)	
4.5 m (14.8 ft)	kg		*6,840	*6,840	*5,750	*5,750	*5,240	4,130	*3,260	*3,260	7.88	
	lb		*15,080	*15,080	*12,680	*12,680	*11,550	9,110	*7,190	*7,190	(25.8)	
3.0 m (9.8 ft)	kg		*8,500	*8,500	*6,480	5,650	*5,510	4,030	*3,330	*3,330	8.22	
	lb		*18,740	*18,740	*14,290	12,460	*12,150	8,880	*7,340	*7,340	(27.0)	
1.5 m (4.9 ft)	kg		*9,840	8,230	*7,170	5,410	*5,820	3,920	*3,540	3,390	8.27	
	lb		*21,690	18,140	*15,810	11,930	*12,830	8,640	*7,800	7,470	(27.1)	
Ground Line	kg	*6,270	*6,270	*10,320	7,980	*7,540	5,250	*5,940	3,840	*3,950	3,490	8.05
	lb	*13,820	*13,820	*22,750	17,590	*16,620	11,570	*13,100	8,470	*8,710	7,690	(26.4)
-1.5 m (-4.9 ft)	kg	*11,690	*11,690	*9,980	7,930	*7,410	5,190	*4,870	3,840	*4,700	3,830	7.51
	lb	*25,770	*25,770	*22,000	17,480	*16,340	11,440	*10,740	8,470	*10,360	8,440	(24.6)
-3.0 m (-9.8 ft)	kg	*12,050	*12,050	*8,810	8,030	*6,470	5,260			*5,530	4,640	6.59
	lb	*26,570	*26,570	*19,420	17,700	*14,260	11,600			*12,190	10,230	(21.6)
-4.5 m (-14.8 ft)	kg		*6,090	*6,090						*5,010	*5,010	5.08
	lb		*13,430	*13,430						*11,050	*11,050	(16.7)



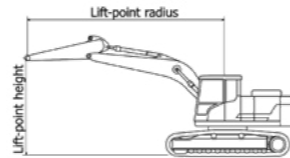









- Lifting capacity are based on ISO 10567.
- Lifting capacity does not exceed 75% of tipping load with the machine on firm, level ground or 87% of full hydraulic capacity.
- The Lift-point is bucket pivot mounting pin on the arm (without bucket mass).
- (*) indicates load limited by hydraulic capacity.















 Rating over-front  Rating over-side or 360 degree

MONO BOOM

5.65 m (18' 6") Mono boom, 2.92m (9' 7") arm and 4 outrigger up.

Lift point height m (ft)	Lift radius								At max. reach					
	1.5 m (4.9 ft)		3.0 m (9.8 ft)		4.5 m (14.8 ft)		6.0 m (19.7 ft)		7.5 m (24.6 ft)		Capacity	Reach		
													m (ft)	
7.5 m (24.6 ft)	kg							*4,680	4,420			*3,140	*3,140	6.39
	lb							*10,320	9,740			*6,920	*6,920	(21.0)
6.0 m (19.7 ft)	kg							*5,020	4,400			*2,900	*2,900	7.45
	lb							*11,070	9,700			*6,390	*6,390	(24.5)
4.5 m (14.8 ft)	kg					*6,500	*6,500	*5,520	4,220	4,370	2,930	*2,840	2,550	8.10
	lb					*14,330	*14,330	*12,170	9,300	9,630	6,460	*6,260	5,620	(26.6)
3.0 m (9.8 ft)	kg					*8,160	6,040	6,030	3,970	4,250	2,830	*2,890	2,320	8.43
	lb					*17,990	13,320	13,290	8,750	9,370	6,240	*6,370	5,110	(27.7)
1.5 m (4.9 ft)	kg					8,960	5,550	5,760	3,730	4,120	2,710	*3,070	2,240	8.49
	lb					19,750	12,240	12,700	8,220	9,080	5,970	*6,770	4,940	(27.8)
Ground Line	kg			*6,650	*6,650	8,650	5,290	5,570	3,570	4,030	2,620	*3,400	2,290	8.27
	lb			*14,660	*14,660	19,070	11,660	12,280	7,870	8,880	5,780	*7,500	5,050	(27.1)
-1.5 m (-4.9 ft)	kg	*7,190	*7,190	*11,250	9,790	8,570	5,220	5,500	3,500	4,000	2,600	3,840	2,500	7.75
	lb	*15,850	*15,850	*24,800	21,580	18,890	11,510	12,130	7,720	8,820	5,730	8,470	5,510	(25.4)
-3.0 m (-9.8 ft)	kg	*11,870	*11,870	*12,450	9,990	8,660	5,290	5,550	3,550			4,610	3,000	6.86
	lb	*26,170	*26,170	*27,450	22,020	19,090	11,660	12,240	7,830			10,160	6,610	(22.5)
-4.5 m (-14.8 ft)	kg			*9,040	*9,040	*6,580	5,520					*4,960	4,290	5.43
	lb			*19,930	*19,930	*14,510	12,170					*10,930	9,460	(17.8)

5.65 m (18' 6") Mono boom, 2.92m (9' 7") arm, outrigger and dozer blade up.













Lift point height m (ft)	Lift radius								At max. reach					
	1.5 m (4.9 ft)		3.0 m (9.8 ft)		4.5 m (14.8 ft)		6.0 m (19.7 ft)		7.5 m (24.6 ft)		Capacity	Reach		
													m (ft)	
7.5 m (24.6 ft)	kg							*4,680	4,410			*3,140	*3,140	6.39
	lb							*10,320	9,720			*6,920	*6,920	(21.0)
6.0 m (19.7 ft)	kg							*5,020	4,390			*2,900	*2,900	7.45
	lb							*11,070	9,680			*6,390	*6,390	(24.5)
4.5 m (14.8 ft)	kg					*6,500	*6,500	*5,520	4,220	4,370	2,930	*2,840	2,550	8.10
	lb					*14,330	*14,330	*12,170	9,300	9,630	6,460	*6,260	5,620	(26.6)
3.0 m (9.8 ft)	kg					*8,160	6,030	6,020	3,970	4,250	2,820	*2,890	2,320	8.43
	lb					*17,990	13,290	13,270	8,750	9,370	6,220	*6,370	5,110	(27.7)
1.5 m (4.9 ft)	kg					8,960	5,540	5,750	3,730	4,120	2,700	*3,070	2,240	8.49
	lb					19,750	12,210	12,680	8,220	9,080	5,950	*6,770	4,940	(27.8)
Ground Line	kg			*6,650	*6,650	8,650	5,280	5,570	3,560	4,030	2,620	*3,400	2,280	8.27
	lb			*14,660	*14,660	19,070	11,640	12,280	7,850	8,880	5,780	*7,500	5,030	(27.1)
-1.5 m (-4.9 ft)	kg	*7,190	*7,190	*11,250	9,770	8,570	5,210	5,500	3,490	4,000	2,590	3,840	2,490	7.75
	lb	*15,850	*15,850	*24,800	21,540	18,890	11,490	12,1						

LIFTING CAPACITY













 Rating over-front  Rating over-side or 360 degree

MONO BOOM

5.65 m (18' 6") Mono boom, 2.92m (9' 7") arm and 4 outrigger down.

Lift point height m (ft)	Lift radius										At max. reach				
	1.5 m (4.9 ft)		3.0 m (9.8 ft)		4.5 m (14.8 ft)		6.0 m (19.7 ft)		7.5 m (24.6 ft)		Capacity		Reach		
													m (ft)		
7.5 m (24.6 ft)	kg										*4,680	*4,680			
	lb										*10,320	*10,320			6.39 (21.0)
6.0 m (19.7 ft)	kg										*5,020	*5,020			7.45
	lb										*11,070	*11,070			(24.5)
4.5 m (14.8 ft)	kg				*6,500	*6,500	*5,520	*5,520	*5,030	4,610	*2,840	*2,840			8.10
	lb				*14,330	*14,330	*12,170	*12,170	*11,090	10,160	*6,260	*6,260			(26.6)
3.0 m (9.8 ft)	kg				*8,160	*8,160	*6,270	*6,270	*5,340	4,490	*2,890	*2,890			8.43
	lb				*17,990	*17,990	*13,820	*13,820	*11,770	9,900	*6,370	*6,370			(27.7)
1.5 m (4.9 ft)	kg				*9,580	9,450	*6,990	6,080	*5,680	4,360	*3,070	*3,070			8.49
	lb				*21,120	20,830	*15,410	13,400	*12,520	9,610	*6,770	*6,770			(27.8)
Ground Line	kg				*6,650	*6,650	*10,180	9,150	*7,420	5,890	*3,400	*3,400			8.27
	lb				*14,660	*14,660	*22,440	20,170	*16,360	12,990	*7,500	*7,500			(27.1)
-1.5 m (-4.9 ft)	kg	*7,190	*7,190	*11,250	*11,250	*9,980	9,070	*7,370	5,820	*5,620	4,240	*4,010	*4,010		7.75
	lb	*15,850	*15,850	*24,800	*24,800	*22,000	20,000	*16,250	12,830	*12,390	9,350	*8,840	*8,840		(25.4)
-3.0 m (-9.8 ft)	kg	*11,870	*11,870	*12,450	*12,450	*8,950	*8,950	*6,600	5,870			*5,240	4,880		6.86
	lb	*26,170	*26,170	*27,450	*27,450	*19,730	*19,730	*14,550	12,940			*11,550	10,760		(22.5)
-4.5 m (-14.8 ft)	kg			*9,040	*9,040	*6,580	*6,580					*4,960	*4,960		5.43
	lb			*19,930	*19,930	*14,510	*14,510					*10,930	*10,930		(17.8)

5.65 m (18' 6") Mono boom, 2.92m (9' 7") arm, outrigger and dozer blade down.

Lift point height m (ft)	Lift radius										At max. reach					
	1.5 m (4.9 ft)		3.0 m (9.8 ft)		4.5 m (14.8 ft)		6.0 m (19.7 ft)		7.5 m (24.6 ft)		Capacity		Reach			
													m (ft)			
7.5 m (24.6 ft)	kg											*4,680	*4,680			
	lb											*10,320	*10,320			6.39 (21.0)
6.0 m (19.7 ft)	kg											*5,020	*5,020			7.45
	lb											*11,070	*11,070			(24.5)
4.5 m (14.8 ft)	kg				*6,500	*6,500	*5,520	*5,520	*5,030	3,910	*2,840	*2,840			8.10	
	lb				*14,330	*14,330	*12,170	*12,170	*11,090	8,620	*6,260	*6,260			(26.6)	
3.0 m (9.8 ft)	kg				*8,160	*8,160	*6,270	5,340	*5,340	3,800	*2,890	*2,890			8.43	
	lb				*17,990	*17,990	*13,820	11,770	*11,770	8,380	*6,370	*6,370			(27.7)	
1.5 m (4.9 ft)	kg				*9,580	7,740	*6,990	5,080	*5,680	3,670	*3,070	3,050			8.49	
	lb				*21,120	17,060	*15,410	11,200	*12,520	8,090	*6,770	6,720			(27.8)	
Ground Line	kg				*6,650	*6,650	*10,180	7,460	*7,420	4,910	*5,850	3,580	*3,400	3,120		8.27
	lb				*14,660	*14,660	*22,440	16,450	*16,360	10,820	*12,900	7,890	*7,500	6,880		(27.1)
-1.5 m (-4.9 ft)	kg	*7,190	*7,190	*11,250	*11,250	*9,980	7,380	*7,370	4,840	*5,620	3,560	*4,010	3,410		7.75	
	lb	*15,850	*15,850	*24,800	*24,800	*22,000	16,270	*16,250	10,670	*12,390	7,850	*8,840	7,520		(25.4)	
-3.0 m (-9.8 ft)	kg	*11,870	*11,870	*12,450	*12,450	*8,950	7,460	*6,600	4,880			*5,240	4,090		6.86	
	lb	*26,170	*26,170	*27,450	*27,450	*19,730	16,450	*14,550	10,760			*11,550	9,020		(22.5)	
-4.5 m (-14.8 ft)	kg			*9,040	*9,040	*6,580	*6,580					*4,960	*4,960		5.43	
	lb			*19,930	*19,930	*14,510	*14,510					*10,930	*10,930		(17.8)	



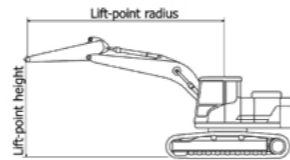









- Lifting capacity are based on ISO 10567.
- Lifting capacity does not exceed 75% of tipping load with the machine on firm, level ground or 87% of full hydraulic capacity.
- The Lift-point is bucket pivot mounting pin on the arm (without bucket mass).
- (*) indicates load limited by hydraulic capacity.















 Rating over-front  Rating over-side or 360 degree

MONO BOOM

5.65 m (18' 6") Mono boom, 2.92m (9' 7") arm, dozer blade and outrigger up.

Lift point height m (ft)	Lift radius										At max. reach					
	1.5 m (4.9 ft)		3.0 m (9.8 ft)		4.5 m (14.8 ft)		6.0 m (19.7 ft)		7.5 m (24.6 ft)		Capacity		Reach			
													m (ft)			
7.5 m (24.6 ft)	kg											*4,680	4,480			
	lb											*10,320	9,880			6.39 (21.0)
6.0 m (19.7 ft)	kg											*5,020	4,460			7.45
	lb											*11,070	9,830			(24.5)
4.5 m (14.8 ft)	kg				*6,500	*6,500	*5,520	4,290	4,380	2,980	*2,840	2,600			8.10	
	lb				*14,330	*14,330	*12,170	9,460	9,660	6,570	*6,260	5,730			(26.6)	
3.0 m (9.8 ft)	kg				*8,160	6,130	6,040	4,040	4,260	2,880	*2,890	2,370			8.43	
	lb				*17,990	13,510	13,320	8,910	9,390	6,350	*6,370	5,220			(27.7)	
1.5 m (4.9 ft)	kg				8,990	5,640	5,770	3,800	4,130	2,760	*3,070	2,280			8.49	
	lb				19,820	12,430	12,720	8,380	9,110	6,080	*6,770	5,030			(27.8)	
Ground Line	kg				*6,650	*6,650	8,680	5,380	5,590	3,630	*3,400	2,330			8.27	
	lb				*14,660	*14,660	19,140	11,860	12,320	8,000	*7,500	5,140			(27.1)	
-1.5 m (-4.9 ft)	kg	*7,190	*7,190	*11,250	9,960	8,600	5,310	5,510	3,570	4,020	2,650	3,850	2,550		7.75	
	lb	*15,850	*15,850	*24,800	21,960	18,960	11,710	12,150	7,870	8,860	5,840	8,490	5,620		(25.4)	
-3.0 m (-9.8 ft)	kg	*11,870	*11,870	*12,450	10,160	8,690	5,390	5,560	3,610			4,630	3,050		6.86	
	lb	*26,170	*26,170	*27,450	22,400	19,160	11,880	12,260	7,960			10,210	6,720		(22.5)	
-4.5 m (-14.8 ft)	kg			*9,040	*9,040	*6,580	5,620					*4,960	4,370		5.43	
	lb			*19,930	*19,930	*14,510	12,390					*10,930	9,630		(17.8)	

5.65 m (18' 6") Mono boom, 2.92m (9' 7") arm, dozer blade and outrigger down.











Lift point height m (ft)	Lift radius										At max. reach					
	1.5 m (4.9 ft)		3.0 m (9.8 ft)		4.5 m (14.8 ft)		6.0 m (19.7 ft)		7.5 m (24.6 ft)		Capacity		Reach			
													m (ft)			
7.5 m (24.6 ft)	kg											*4,680	*4,680			
	lb											*10,320	*10,320			6.39 (21.0)
6.0 m (19.7 ft)	kg											*5,020	*5,020			7.45
	lb											*11,070	*11,070			(24.5)
4.5 m (14.8 ft)	kg				*6,500	*6,500	*5,520	*5,520	*5,030	4,110	*2,840	*2,840			8.10	
	lb				*14,330	*14,330	*12,170	*12,170	*11,090	9,060	*6,260	*6,260			(26.6)	
3.0 m (9.8 ft)	kg				*8,160	*8,160	*6,270	5,620	*5,340	4,000	*2,890	*2,890			8.43	
	lb				*17,990	*17,990	*13,820	12,390	*11,770	8,820	*6,370	*6,370			(27.7)	
1.5 m (4.9 ft)	kg				*9,580	8,190	*6,990	5,360	*5,680	3,870	*3,070	*3,070			8.49	
	lb				*21,120	18,060	*15,410	11,820	*12,520	8,530	*6,770	*6,770			(27.8)	
Ground Line	kg				*6,650	*6,650	*10,180	7,900	*7,420	5,180	*5,850	3,780	*3,400	3,300		8.27
	lb				*14,660	*14,660	*22,440	17,420	*16,360	11,420	*12,900	8,330	*7,500	7,280		(27.1)
-1.5 m (-4.9 ft)	kg	*7,190	*7,190	*11,250	*11											

LIFTING CAPACITY











 Rating over-front  Rating over-side or 360 degree

2-PIECE BOOM

5.4m (17' 9") 2-Piece boom, 2.40 m (7' 10") arm and 4 outrigger up.

Lift point height m (ft)	Lift radius								At max. reach		
	3.0 m (9.8 ft)		4.5 m (14.8 ft)		6.0 m (19.7 ft)		7.5 m (24.6 ft)		Capacity	Reach	
											m (ft)
7.5 m (24.6 ft)	kg		*4,680	*4,680					*5,110	*5,110	5.48 (18.0)
	lb		*10,320	*10,320					*11,270	*11,270	
6.0 m (19.7 ft)	kg		*4,810	*4,810	*4,800	4,740			*4,720	3,920	6.69 (22.0)
	lb		*10,600	*10,600	*10,580	10,450			*10,410	8,640	
4.5 m (14.8 ft)	kg	*7,890	*7,890	*5,910	*5,910	*5,170	4,610		*4,510	3,280	7.41 (24.3)
	lb	*17,390	*17,390	*13,030	*13,030	*11,400	10,160		*9,940	7,230	
3.0 m (9.8 ft)	kg		*7,600	6,610	*5,920	4,400	4,680	3,160	4,420	2,980	7.77 (25.5)
	lb		*16,760	14,570	*13,050	9,700	10,320	6,970	9,740	6,570	
1.5 m (4.9 ft)	kg		*9,200	6,190	6,370	4,200	4,590	3,080	4,310	2,890	7.83 (25.7)
	lb		*20,280	13,650	14,040	9,260	10,120	6,790	9,500	6,370	
Ground Line	kg		9,640	6,000	6,220	4,070	4,540	3,030	4,470	2,990	7.59 (24.9)
	lb		21,250	13,230	13,710	8,970	10,010	6,680	9,850	6,590	
-1.5 m (-4.9 ft)	kg	*12,480	11,190	9,620	5,990	6,200	4,050		5,000	3,330	7.02 (23.0)
	lb	*27,510	24,670	21,210	13,210	13,670	8,930		11,020	7,340	

5.4m (17' 9") 2-Piece boom, 2.40 m (7' 10") arm, outrigger and dozer blade up.

Lift point height m (ft)	Lift radius								At max. reach		
	3.0 m (9.8 ft)		4.5 m (14.8 ft)		6.0 m (19.7 ft)		7.5 m (24.6 ft)		Capacity	Reach	
											m (ft)
7.5 m (24.6 ft)	kg		*4,680	*4,680					*5,110	*5,110	5.48 (18.0)
	lb		*10,320	*10,320					*11,270	*11,270	
6.0 m (19.7 ft)	kg		*4,810	*4,810	*4,800	4,750			*4,720	3,930	6.69 (22.0)
	lb		*10,600	*10,600	*10,580	10,470			*10,410	8,660	
4.5 m (14.8 ft)	kg	*7,890	*7,890	*5,910	*5,910	*5,170	4,620		*4,510	3,290	7.41 (24.3)
	lb	*17,390	*17,390	*13,030	*13,030	*11,400	10,190		*9,940	7,250	
3.0 m (9.8 ft)	kg		*7,600	6,620	*5,920	4,410	4,680	3,170	4,420	2,990	7.77 (25.5)
	lb		*16,760	14,590	*13,050	9,720	10,320	6,990	9,740	6,590	
1.5 m (4.9 ft)	kg		*9,200	6,210	6,370	4,210	4,590	3,080	4,310	2,900	7.83 (25.7)
	lb		*20,280	13,690	14,040	9,280	10,120	6,790	9,500	6,390	
Ground Line	kg		9,640	6,010	6,220	4,080	4,540	3,040	4,470	2,990	7.59 (24.9)
	lb		21,250	13,250	13,710	8,990	10,010	6,700	9,850	6,590	
-1.5 m (-4.9 ft)	kg	*12,480	11,210	9,620	6,000	6,200	4,060		5,000	3,340	7.02 (23.0)
	lb	*27,510	24,710	21,210	13,230	13,670	8,950		11,020	7,360	



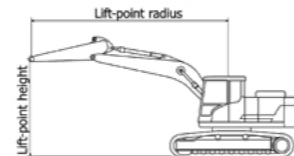







- Lifting capacity are based on ISO 10567.
- Lifting capacity does not exceed 75% of tipping load with the machine on firm, level ground or 87% of full hydraulic capacity.
- The Lift-point is bucket pivot mounting pin on the arm (without bucket mass).
- (*) indicates load limited by hydraulic capacity.













 Rating over-front  Rating over-side or 360 degree

2-PIECE BOOM

5.4m (17' 9") 2-Piece boom, 2.40 m (7' 10") arm and 4 outrigger down.

Lift point height m (ft)	Lift radius								At max. reach		
	3.0 m (9.8 ft)		4.5 m (14.8 ft)		6.0 m (19.7 ft)		7.5 m (24.6 ft)		Capacity	Reach	
											m (ft)
7.5 m (24.6 ft)	kg		*4,680	*4,680					*5,110	*5,110	5.48 (18.0)
	lb		*10,320	*10,320					*11,270	*11,270	
6.0 m (19.7 ft)	kg		*4,810	*4,810	*4,800	*4,800			*4,720	*4,720	6.69 (22.0)
	lb		*10,600	*10,600	*10,580	*10,580			*10,410	*10,410	
4.5 m (14.8 ft)	kg	*7,890	*7,890	*5,910	*5,910	*5,170	*5,170		*4,510	*4,510	7.41 (24.3)
	lb	*17,390	*17,390	*13,030	*13,030	*11,400	*11,400		*9,940	*9,940	
3.0 m (9.8 ft)	kg		*7,600	*7,600	*5,920	*5,920	*5,290	4,920	*4,520	*4,520	7.77 (25.5)
	lb		*16,760	*16,760	*13,050	*13,050	*11,660	10,850	*9,960	*9,960	
1.5 m (4.9 ft)	kg		*9,200	*9,200	*6,740	6,690	*5,660	4,830	*4,740	4,540	7.83 (25.7)
	lb		*20,280	*20,280	*14,860	14,750	*12,480	10,650	*10,450	10,010	
Ground Line	kg		*10,120	*10,120	*7,360	6,550	*5,950	4,780	*5,210	4,710	7.59 (24.9)
	lb		*22,310	*22,310	*16,230	14,440	*13,120	10,540	*11,490	10,380	
-1.5 m (-4.9 ft)	kg	*12,480	*12,480	*10,310	10,120	*7,570	6,520		*6,130	5,270	7.02 (23.0)
	lb	*27,510	*27,510	*22,730	22,310	*16,690	14,370		*13,510	11,620	

5.4m (17' 9") 2-Piece boom, 2.40 m (7' 10") arm, outrigger and dozer blade down

Lift point height m (ft)	Lift radius								At max. reach		
	3.0 m (9.8 ft)		4.5 m (14.8 ft)		6.0 m (19.7 ft)		7.5 m (24.6 ft)		Capacity	Reach	
											m (ft)
7.5 m (24.6 ft)	kg		*4,680	*4,680					*5,110	*5,110	5.48 (18.0)
	lb		*10,320	*10,320					*11,270	*11,270	
6.0 m (19.7 ft)	kg		*4,810	*4,810	*4,800	*4,800			*4,720	*4,720	6.69 (22.0)
	lb		*10,600	*10,600	*10,580	*10,580			*10,410	*10,410	
4.5 m (14.8 ft)	kg	*7,890	*7,890	*5,910	*5,910	*5,170	*5,170		*4,510	4,330	7.41 (24.3)
	lb	*17,390	*17,390	*13,030	*13,030	*11,400	*11,400		*9,940	9,550	
3.0 m (9.8 ft)	kg		*7,600	*7,600	*5,920	5,850	*5,290	4,190	*4,520	3,960	7.77 (25.5)
	lb		*16,760	*16,760	*13,050	12,900	*11,660	9,240	*9,960	8,730	
1.5 m (4.9 ft)	kg		*9,200	8,540	*6,740	5,640	*5,660	4,100	*4,740	3,860	7.83 (25.7)
	lb		*20,280	18,830	*14,860	12,430	*12,480	9,040	*10,450	8,510	
Ground Line	kg		*10,120	8,330	*7,360	5,500	*5,950	4,050	*5,210	3,990	7.59 (24.9)
	lb		*22,310	18,360	*16,230	12,130	*13,120	8,930	*11,490	8,800	
-1.5 m (-4.9 ft)	kg	*12,480	*12,480	*10,310	8,310	*7,570	5,480		*6,130	4,460	7.02 (23.0)
	lb	*27,510	*27,510	*22,730	18,320	*16,690	12,080		*13,510	9,830	

- Lifting capacity are based on ISO 10567.
- Lifting capacity does not exceed 75% of tipping load with the machine on firm, level ground or 87% of full hydraulic capacity.
- The Lift-point is bucket pivot mounting pin on the arm (without bucket mass).
- (*) indicates load limited by hydraulic capacity.

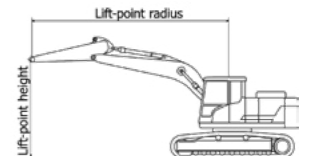

LIFTING CAPACITY

Rating over-front Rating over-side or 360 degree

2-PIECE BOOM

5.4m (17' 9") 2-Piece boom, 2.40 m (7' 10") arm, dozer blade and outrigger up.

Lift point height m (ft)	Lift radius								At max. reach		
	3.0 m (9.8 ft)		4.5 m (14.8 ft)		6.0 m (19.7 ft)		7.5 m (24.6 ft)		Capacity	Reach	
7.5 m (24.6 ft)	kg		*4,680	*4,680					*5,110	*5,110	5.48
	lb		*10,320	*10,320					*11,270	*11,270	(18.0)
6.0 m (19.7 ft)	kg		*4,810	*4,810	*4,800	*4,800			*4,720	3,990	6.69
	lb		*10,600	*10,600	*10,580	*10,580			*10,410	8,800	(22.0)
4.5 m (14.8 ft)	kg	*7,890	*7,890	*5,910	*5,910	*5,170	4,680		*4,510	3,340	7.41
	lb	*17,390	*17,390	*13,030	*13,030	*11,400	10,320		*9,940	7,360	(24.3)
3.0 m (9.8 ft)	kg		*7,600	6,720	*5,920	4,470	4,700	3,220	4,430	3,040	7.77
	lb		*16,760	14,820	*13,050	9,850	10,360	7,100	9,770	6,700	(25.5)
1.5 m (4.9 ft)	kg		*9,200	6,300	6,390	4,270	4,610	3,130	4,320	2,950	7.83
	lb		*20,280	13,890	14,090	9,410	10,160	6,900	9,520	6,500	(25.7)
Ground Line	kg		9,670	6,110	6,240	4,140	4,560	3,090	4,490	3,040	7.59
	lb		21,320	13,470	13,760	9,130	10,050	6,810	9,900	6,700	(24.9)
-1.5 m (-4.9 ft)	kg	*12,480	11,370	9,650	6,090	6,220	4,120		5,020	3,390	7.02
	lb	*27,510	25,070	21,270	13,430	13,710	9,080		11,070	7,470	(23.0)

5.4m (17' 9") 2-Piece boom, 2.40 m (7' 10") arm, dozer blade and outrigger down.

Lift point height m (ft)	Lift radius								At max. reach		
	3.0 m (9.8 ft)		4.5 m (14.8 ft)		6.0 m (19.7 ft)		7.5 m (24.6 ft)		Capacity	Reach	
7.5 m (24.6 ft)	kg		*4,680	*4,680					*5,110	*5,110	5.48
	lb		*10,320	*10,320					*11,270	*11,270	(18.0)
6.0 m (19.7 ft)	kg		*4,810	*4,810	*4,800	*4,800			*4,720	*4,720	6.69
	lb		*10,600	*10,600	*10,580	*10,580			*10,410	*10,410	(22.0)
4.5 m (14.8 ft)	kg	*7,890	*7,890	*5,910	*5,910	*5,170	*5,170		*4,510	*4,510	7.41
	lb	*17,390	*17,390	*13,030	*13,030	*11,400	*11,400		*9,940	*9,940	(24.3)
3.0 m (9.8 ft)	kg		*7,600	*7,600	*5,920	*5,920	*5,290	4,400	*4,520	4,150	7.77
	lb		*16,760	*16,760	*13,050	*13,050	*11,660	9,700	*9,960	9,150	(25.5)
1.5 m (4.9 ft)	kg		*9,200	9,010	*6,740	5,920	*5,660	4,310	*4,740	4,050	7.83
	lb		*20,280	19,860	*14,860	13,050	*12,480	9,500	*10,450	8,930	(25.7)
Ground Line	kg		*10,120	8,790	*7,360	5,790	*5,950	4,260	*5,210	4,200	7.59
	lb		*22,310	19,380	*16,230	12,760	*13,120	9,390	*11,490	9,260	(24.9)
-1.5 m (-4.9 ft)	kg	*12,480	*12,480	*10,310	8,780	*7,570	5,760		*6,130	4,680	7.02
	lb	*27,510	*27,510	*22,730	19,360	*16,690	12,700		*13,510	10,320	(23.0)

- Lifting capacity are based on ISO 10567.
- Lifting capacity does not exceed 75% of tipping load with the machine on firm, level ground or 87% of full hydraulic capacity.
- The Lift-point is bucket pivot mounting pin on the arm (without bucket mass).
- (*) indicates load limited by hydraulic capacity.

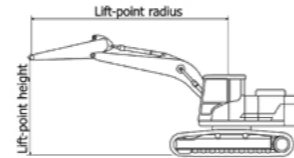

Rating over-front Rating over-side or 360 degree

2-PIECE BOOM

5.4m (17' 9") 2-Piece boom, 2.70 (8' 10") arm and 4 outrigger up.

Lift point height m (ft)	Lift radius								At max. reach			
	3.0 m (9.8 ft)		4.5 m (14.8 ft)		6.0 m (19.7 ft)		7.5 m (24.6 ft)		Capacity	Reach		
9.0 m (29.5 ft)	kg								*5,310	*5,310	3.87	
	lb								*11,710	*11,710	(12.7)	
7.5 m (24.6 ft)	kg								*4,030	*4,030	5.87	
	lb								*8,880	*8,880	(19.3)	
6.0 m (19.7 ft)	kg		*4,450	*4,450	*4,510	*4,510			*3,610	*3,610	7.02	
	lb		*9,810	*9,810	*9,940	*9,940			*7,960	*7,960	(23.0)	
4.5 m (14.8 ft)	kg	*7,030	*7,030	*5,540	*5,540	*4,940	4,670	4,810	3,280	*3,460	3,120	7.71
	lb	*15,500	*15,500	*12,210	*12,210	*10,890	10,300	10,600	7,230	*7,630	6,880	(25.3)
3.0 m (9.8 ft)	kg		*7,250	6,730	*5,720	4,460	4,720	3,200	*3,480	2,850	8.05	
	lb		*15,980	14,840	*12,610	9,830	10,410	7,050	*7,670	6,280	(26.4)	
1.5 m (4.9 ft)	kg		*8,940	6,280	6,410	4,240	4,620	3,100	*3,640	2,770	8.11	
	lb		*19,710	13,850	14,130	9,350	10,190	6,830	*8,020	6,110	(26.6)	
Ground Line	kg	*6,490	*6,490	9,690	6,050	6,250	4,100	4,550	3,040	*3,990	2,850	7.88
	lb	*14,310	*14,310	21,360	13,340	13,780	9,040	10,030	6,700	*8,800	6,280	(25.8)
-1.5 m (-4.9 ft)	kg	*12,120	11,170	9,630	6,000	6,200	4,050		*4,660	3,140	7.33	
	lb	*26,720	24,630	21,230	13,230	13,670	8,930		*10,270	6,920	(24.1)	
-3.0 m (-9.8 ft)	kg			9,740	6,100							
	lb			21,470	13,450							

5.4m (17' 9") 2-Piece boom, 2.70 (8' 10") arm, outrigger and dozer blade up.

Lift point height m (ft)	Lift radius								At max. reach			
	3.0 m (9.8 ft)		4.5 m (14.8 ft)		6.0 m (19.7 ft)		7.5 m (24.6 ft)		Capacity	Reach		
9.0 m (29.5 ft)	kg								*5,310	*5,310	3.87	
	lb								*11,710	*11,710	(12.7)	
7.5 m (24.6 ft)	kg								*4,030	*4,030	5.87	
	lb								*8,880	*8,880	(19.3)	
6.0 m (19.7 ft)	kg		*4,450	*4,450	*4,510	*4,510			*3,610	*3,610	7.02	
	lb		*9,810	*9,810	*9,940	*9,940			*7,960	*7,960	(23.0)	
4.5 m (14.8 ft)	kg	*7,030	*7,030	*5,540	*5,540	*4,940	4,680	4,810	3,280	*3,460	3,130	7.71
	lb	*15,500	*15,500	*12,210	*12,210	*10,890	10,320	10,600	7,230	*7,630	6,900	(25.3)
3.0 m (9.8 ft)	kg		*7,250	6,740	*5,720	4,460	4,720	3,200	*3,480	2,860	8.05	
	lb		*15,980	14,860	*12,610	9,830	10,410	7,050	*7,670	6,310	(26.4)	
1.5 m (4.9 ft)	kg		*8,940	6,290	6,410	4,250	4,620	3,110	*3,640	2,770	8.11	
	lb		*19,710	13,870	14,130	9,370	10,190	6,860	*8,020	6,110	(26.6)	
Ground Line	kg	*6,490	*6,490	9,690	6,060	6,250	4,110	4,550	3,040	*3,990	2,850	7.88
	lb	*14,310	*14,310	21,360	13,360	13,780	9,060	10,030	6,700	*8,800	6,280	(25.8)
-1.5 m (-4.9 ft)	kg	*12,120	11,190	9,630	6,010	6,200	4,060		*4,660	3,150	7.33	
	lb	*26,720	24,670	21,230	13,250	13,670	8,950		*10,270	6,940	(24.1)	
-3.0 m (-9.8 ft)	kg			9,740	6,110							
	lb			21,470	13,470							

- Lifting capacity are based on ISO 10567.
- Lifting capacity does not exceed 75% of tipping load with the machine on firm, level ground or 87% of full hydraulic capacity.
- The Lift-point is bucket pivot mounting pin on the arm (without bucket mass).
- (*) indicates load limited by hydraulic capacity.

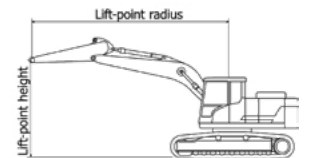

LIFTING CAPACITY

Rating over-front Rating over-side or 360 degree

2-PIECE BOOM

5.4m (17' 9") 2-Piece boom, 2.70 (8' 10") arm and 4 outrigger down.

Lift point height m (ft)	Lift radius								At max. reach			
	3.0 m (9.8 ft)		4.5 m (14.8 ft)		6.0 m (19.7 ft)		7.5 m (24.6 ft)		Capacity	Reach		
9.0 m (29.5 ft)	kg								*5,310	*5,310	3.87	
	lb								*11,710	*11,710	(12.7)	
7.5 m (24.6 ft)	kg								*4,030	*4,030	5.87	
	lb								*8,880	*8,880	(19.3)	
6.0 m (19.7 ft)	kg		*4,450	*4,450	*4,510	*4,510			*3,610	*3,610	7.02	
	lb		*9,810	*9,810	*9,940	*9,940			*7,960	*7,960	(23.0)	
4.5 m (14.8 ft)	kg	*7,030	*7,030	*5,540	*5,540	*4,940	*4,940	*4,820	*4,820	*3,460	*3,460	7.71
	lb	*15,500	*15,500	*12,210	*12,210	*10,890	*10,890	*10,630	*10,630	*7,630	*7,630	(25.3)
3.0 m (9.8 ft)	kg		*7,250	*7,250	*5,720	*5,720	*5,100	4,960	*3,480	*3,480	8.05	
	lb		*15,980	*15,980	*12,610	*12,610	*11,240	10,930	*7,670	*7,670	(26.4)	
1.5 m (4.9 ft)	kg		*8,940	*8,940	*6,580	*6,580	*5,530	4,860	*3,640	*3,640	8.11	
	lb		*19,710	*19,710	*14,510	*14,510	*12,190	10,710	*8,020	*8,020	(26.6)	
Ground Line	kg	*6,490	*6,490	*10,010	*10,010	*7,270	6,580	*5,890	4,790	*3,990	*3,990	7.88
	lb	*14,310	*14,310	*22,070	*22,070	*16,030	14,510	*12,990	10,560	*8,800	*8,800	(25.8)
-1.5 m (-4.9 ft)	kg	*12,120	*12,120	*10,360	10,130	*7,590	6,530		*4,660	*4,660	7.33	
	lb	*26,720	*26,720	*22,840	22,330	*16,730	14,400		*10,270	*10,270	(24.1)	
-3.0 m (-9.8 ft)	kg		*9,890	*9,890								
	lb		*21,800	*21,800								

5.4m (17' 9") 2-Piece boom, 2.70 (8' 10") arm, outrigger and dozer blade down.

Lift point height m (ft)	Lift radius								At max. reach			
	3.0 m (9.8 ft)		4.5 m (14.8 ft)		6.0 m (19.7 ft)		7.5 m (24.6 ft)		Capacity	Reach		
9.0 m (29.5 ft)	kg								*5,310	*5,310	3.87	
	lb								*11,710	*11,710	(12.7)	
7.5 m (24.6 ft)	kg								*4,030	*4,030	5.87	
	lb								*8,880	*8,880	(19.3)	
6.0 m (19.7 ft)	kg		*4,450	*4,450	*4,510	*4,510			*3,610	*3,610	7.02	
	lb		*9,810	*9,810	*9,940	*9,940			*7,960	*7,960	(23.0)	
4.5 m (14.8 ft)	kg	*7,030	*7,030	*5,540	*5,540	*4,940	*4,940	*4,820	4,310	*3,460	*3,460	7.71
	lb	*15,500	*15,500	*12,210	*12,210	*10,890	*10,890	*10,630	9,500	*7,630	*7,630	(25.3)
3.0 m (9.8 ft)	kg		*7,250	*7,250	*5,720	*5,720	*5,100	4,230	*3,480	*3,480	8.05	
	lb		*15,980	*15,980	*12,610	*12,610	*11,240	9,330	*7,670	*7,670	(26.4)	
1.5 m (4.9 ft)	kg		*8,940	8,630	*6,580	5,680	*5,530	4,130	*3,640	*3,640	8.11	
	lb		*19,710	19,030	*14,510	12,520	*12,190	9,110	*8,020	*8,020	(26.6)	
Ground Line	kg	*6,490	*6,490	*10,010	8,380	*7,270	5,530	*5,890	4,060	*3,990	3,800	7.88
	lb	*14,310	*14,310	*22,070	18,470	*16,030	12,190	*12,990	8,950	*8,800	8,380	(25.8)
-1.5 m (-4.9 ft)	kg	*12,120	*12,120	*10,360	8,330	*7,590	5,480		*4,660	4,200	7.33	
	lb	*26,720	*26,720	*22,840	18,360	*16,730	12,080		*10,270	9,260	(24.1)	
-3.0 m (-9.8 ft)	kg		*9,890	8,430								
	lb		*21,800	18,580								

- Lifting capacity are based on ISO 10567.
- Lifting capacity does not exceed 75% of tipping load with the machine on firm, level ground or 87% of full hydraulic capacity.
- The Lift-point is bucket pivot mounting pin on the arm (without bucket mass).
- (*) indicates load limited by hydraulic capacity.

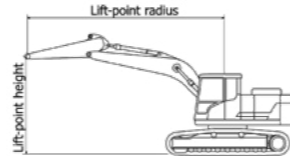

Rating over-front Rating over-side or 360 degree

2-PIECE BOOM

5.4m (17' 9") 2-Piece boom, 2.70 (8' 10") arm, dozer blade and outrigger up.

Lift point height m (ft)	Lift radius								At max. reach			
	3.0 m (9.8 ft)		4.5 m (14.8 ft)		6.0 m (19.7 ft)		7.5 m (24.6 ft)		Capacity	Reach		
9.0 m (29.5 ft)	kg								*5,310	*5,310	3.87	
	lb								*11,710	*11,710	(12.7)	
7.5 m (24.6 ft)	kg								*4,030	*4,030	5.87	
	lb								*8,880	*8,880	(19.3)	
6.0 m (19.7 ft)	kg		*4,450	*4,450	*4,510	*4,510			*3,610	*3,610	7.02	
	lb		*9,810	*9,810	*9,940	*9,940			*7,960	*7,960	(23.0)	
4.5 m (14.8 ft)	kg	*7,030	*7,030	*5,540	*5,540	*4,940	4,750	4,820	3,330	*3,460	3,170	7.71
	lb	*15,500	*15,500	*12,210	*12,210	*10,890	10,470	10,630	7,340	*7,630	6,990	(25.3)
3.0 m (9.8 ft)	kg		*7,250	6,830	*5,720	4,530	4,740	3,250		*3,480	2,900	8.05
	lb		*15,980	15,060	*12,610	9,990	10,450	7,170		*7,670	6,390	(26.4)
1.5 m (4.9 ft)	kg		*8,940	6,390	*6,580	4,320	4,630	3,160		*3,640	2,820	8.11
	lb		*19,710	14,090	*14,510	9,520	10,210	6,970		*8,020	6,220	(26.6)
Ground Line	kg	*6,490	*6,490	*9,720	6,160	*6,270	4,170	4,560	3,090	*3,990	2,900	7.88
	lb	*14,310	*14,310	21,430	13,580	13,820	9,190	10,050	6,810	*8,800	6,390	(25.8)
-1.5 m (-4.9 ft)	kg	*12,120	11,360	9,660	6,110	6,220	4,130			*4,660	3,200	7.33
	lb	*26,720	25,040	21,300	13,470	13,710	9,110			*10,270	7,050	(24.1)
-3.0 m (-9.8 ft)	kg			9,770	6,200							
	lb			21,540	13,670							

5.4m (17' 9") 2-Piece boom, 2.70 (8' 10") arm, dozer blade and outrigger down.

Lift point height m (ft)	Lift radius								At max. reach			
	3.0 m (9.8 ft)		4.5 m (14.8 ft)		6.0 m (19.7 ft)		7.5 m (24.6 ft)		Capacity	Reach		
9.0 m (29.5 ft)	kg								*5,310	*5,310	3.87	
	lb								*11,710	*11,710	(12.7)	
7.5 m (24.6 ft)	kg								*4,030	*4,030	5.87	
	lb								*8,880	*8,880	(19.3)	
6.0 m (19.7 ft)	kg		*4,450	*4,450	*4,510	*4,510			*3,610	*3,610	7.02	
	lb		*9,810	*9,810	*9,940	*9,940			*7,960	*7,960	(23.0)	
4.5 m (14.8 ft)	kg	*7,030	*7,030	*5,540	*5,540	*4,940	*4,940	*4,820	4,520	*3,460	*3,460	7.71
	lb	*15,500	*15,500	*12,210	*12,210	*10,890	*10,890	*10,630	9,960	*7,630	*7,630	(25.3)
3.0 m (9.8 ft)	kg		*7,250	*7,250	*5,720	*5,720	*5,100	4,440		*3,480	*3,480	8.05
	lb		*15,980	*15,980	*12,610	*12,610	*11,240	9,790		*7,670	*7,670	(26.4)
1.5 m (4.9 ft)	kg		*8,940	*8,940	*6,580	5,970	*5,530	4,330		*3,640	*3,640	8.11
	lb		*19,710	*19,710	*14,510	13,160	*12,190	9,550		*8,020	*8,020	(26.6)
Ground Line	kg	*6,490	*6,490	*10,010	8,850	*7,270	5,820	*5,890	4,270	*3,990	*3,990	7.88
	lb	*14,310	*14,310	*22,070	19,510	*16,030	12,830	*12,990	9,410	*8,800	*8,800	(25.8)
-1.5 m (-4.9 ft)	kg	*12,120	*12,120	*10,360	8,790	*7,590	5,770			*4,660	4,410	7.33
	lb	*26,720	*26,720	*22,840	19,380	*16,730	12,720			*10,270	9,720	(24.1)
-3.0 m (-9.8 ft)	kg			*9,890	8,900							
	lb			*21,800	19,620							

- Lifting capacity are based on ISO 10567.
- Lifting capacity does not exceed 75% of tipping load with the machine on firm, level ground or 87% of full hydraulic capacity.
- The Lift-point is bucket pivot mounting pin on the arm (without bucket mass).
- (*) indicates load limited by hydraulic capacity.

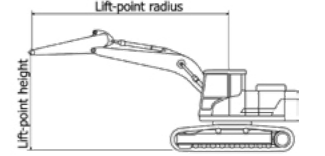











LIFTING CAPACITY











 Rating over-front  Rating over-side or 360 degree

2-PIECE BOOM

5.4m (17' 9") 2-Piece boom, 2.92m (9' 7") arm and 4 outrigger up.

Lift point height m (ft)	Lift radius								At max. reach			
	3.0 m (9.8 ft)		4.5 m (14.8 ft)		6.0 m (19.7 ft)		7.5 m (24.6 ft)		Capacity	Reach		
												
9.0 m (29.5 ft)	kg								*4,500	*4,500	4.31	
	lb								*9,920	*9,920	(14.2)	
7.5 m (24.6 ft)	kg			*4,450	*4,450				*3,510	*3,510	6.17	
	lb			*9,810	*9,810				*7,740	*7,740	(20.3)	
6.0 m (19.7 ft)	kg			*4,230	*4,230				*3,160	*3,160	7.27	
	lb			*9,330	*9,330				*6,970	*6,970	(23.9)	
4.5 m (14.8 ft)	kg		*5,190	*5,190	*4,680	4,660	*4,560	3,250	*3,030	2,940	7.93	
	lb		*11,440	*11,440	*10,320	10,270	*10,050	7,170	*6,680	6,480	(26.0)	
3.0 m (9.8 ft)	kg		*6,890	6,730	*5,480	4,430	4,690	3,160	*3,040	2,690	8.27	
	lb		*15,190	14,840	*12,080	9,770	10,340	6,970	*6,700	5,930	(27.1)	
1.5 m (4.9 ft)	kg		*8,620	6,250	*6,370	4,200	4,570	3,050	*3,180	2,610	8.33	
	lb		*19,000	13,780	*14,040	9,260	10,080	6,720	*7,010	5,750	(27.3)	
Ground Line	kg	*6,800	*6,800	9,620	5,980	6,190	4,040	4,490	2,980	*3,470	2,680	8.10
	lb	*14,990	*14,990	21,210	13,180	13,650	8,910	9,900	6,570	*7,650	5,910	(26.6)
-1.5 m (-4.9 ft)	kg	*11,610	10,990	9,530	5,900	6,120	3,980	4,490	2,980	*4,010	2,940	7.57
	lb	*25,600	24,230	21,010	13,010	13,490	8,770	9,900	6,570	*8,840	6,480	(24.8)
-3.0 m (-9.8 ft)	kg			9,620	5,980	6,190	4,040					
	lb			21,210	13,180	13,650	8,910					

5.4m (17' 9") 2-Piece boom, 2.92m (9' 7") arm, outrigger and dozer blade up.

Lift point height m (ft)	Lift radius								At max. reach			
	3.0 m (9.8 ft)		4.5 m (14.8 ft)		6.0 m (19.7 ft)		7.5 m (24.6 ft)		Capacity	Reach		
												
9.0 m (29.5 ft)	kg								*4,500	*4,500	4.31	
	lb								*9,920	*9,920	(14.2)	
7.5 m (24.6 ft)	kg			*4,450	*4,450				*3,510	*3,510	6.17	
	lb			*9,810	*9,810				*7,740	*7,740	(20.3)	
6.0 m (19.7 ft)	kg			*4,230	*4,230				*3,160	*3,160	7.27	
	lb			*9,330	*9,330				*6,970	*6,970	(23.9)	
4.5 m (14.8 ft)	kg		*5,190	*5,190	*4,680	4,670	*4,560	3,260	*3,030	2,940	7.93	
	lb		*11,440	*11,440	*10,320	10,300	*10,050	7,190	*6,680	6,480	(26.0)	
3.0 m (9.8 ft)	kg		*6,890	6,740	*5,480	4,440	4,690	3,170	*3,040	2,700	8.27	
	lb		*15,190	14,860	*12,080	9,790	10,340	6,990	*6,700	5,950	(27.1)	
1.5 m (4.9 ft)	kg		*8,620	6,260	*6,370	4,210	4,570	3,060	*3,180	2,620	8.33	
	lb		*19,000	13,800	*14,040	9,280	10,080	6,750	*7,010	5,780	(27.3)	
Ground Line	kg	*6,800	*6,800	9,620	5,990	6,190	4,040	4,490	2,980	*3,470	2,690	8.10
	lb	*14,990	*14,990	21,210	13,210	13,650	8,910	9,900	6,570	*7,650	5,930	(26.6)
-1.5 m (-4.9 ft)	kg	*11,610	11,010	9,530	5,910	6,120	3,980	4,490	2,980	*4,010	2,950	7.57
	lb	*25,600	24,270	21,010	13,030	13,490	8,770	9,900	6,570	*8,840	6,500	(24.8)
-3.0 m (-9.8 ft)	kg			9,620	5,990	6,190	4,040					
	lb			21,210	13,210	13,650	8,910					



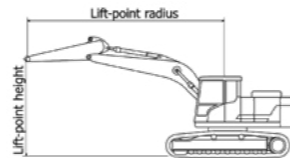







- Lifting capacity are based on ISO 10567.
- Lifting capacity does not exceed 75% of tipping load with the machine on firm, level ground or 87% of full hydraulic capacity.
- The Lift-point is bucket pivot mounting pin on the arm (without bucket mass).
- (*) indicates load limited by hydraulic capacity.













 Rating over-front  Rating over-side or 360 degree

2-PIECE BOOM

5.4m (17' 9") 2-Piece boom, 2.92m (9' 7") arm and 4 outrigger down.

Lift point height m (ft)	Lift radius								At max. reach		
	3.0 m (9.8 ft)		4.5 m (14.8 ft)		6.0 m (19.7 ft)		7.5 m (24.6 ft)		Capacity	Reach	
											
9.0 m (29.5 ft)	kg								*4,500	*4,500	4.31
	lb								*9,920	*9,920	(14.2)
7.5 m (24.6 ft)	kg			*4,450	*4,450				*3,510	*3,510	6.17
	lb			*9,810	*9,810				*7,740	*7,740	(20.3)
6.0 m (19.7 ft)	kg			*4,230	*4,230				*3,160	*3,160	7.27
	lb			*9,330	*9,330				*6,970	*6,970	(23.9)
4.5 m (14.8 ft)	kg		*5,190	*5,190	*4,680	*4,680	*4,560	*4,560	*3,030	*3,030	7.93
	lb		*11,440	*11,440	*10,320	*10,320	*10,050	*10,050	*6,680	*6,680	(26.0)
3.0 m (9.8 ft)	kg		*6,890	*6,890	*5,480	*5,480	*4,890	*4,890	*3,040	*3,040	8.27
	lb		*15,190	*15,190	*12,080	*12,080	*10,780	*10,780	*6,700	*6,700	(27.1)
1.5 m (4.9 ft)	kg		*8,620	*8,620	*6,370	*6,370	*5,350	4,810	*3,180	*3,180	8.33
	lb		*19,000	*19,000	*14,040	*14,040	*11,790	10,600	*7,010	*7,010	(27.3)
Ground Line	kg	*6,800	*6,800	*9,780	*9,780	*7,100	6,520	4,730	*3,470	*3,470	8.10
	lb	*14,990	*14,990	*21,560	*21,560	*15,650	14,370	10,430	*7,650	*7,650	(26.6)
-1.5 m (-4.9 ft)	kg	*11,610	*11,610	*10,240	10,030	*7,480	6,450	4,730	*4,010	*4,010	7.57
	lb	*25,600	*25,600	*22,580	22,110	*16,490	14,220	10,430	*8,840	*8,840	(24.8)
-3.0 m (-9.8 ft)	kg			*9,920	*9,920	*7,230	6,520				
	lb			*21,870	*21,870	*15,940	14,370				

5.4m (17' 9") 2-Piece boom, 2.92m (9' 7") arm, outrigger and dozer blade down.

Lift point height m (ft)	Lift radius								At max. reach		
	3.0 m (9.8 ft)		4.5 m (14.8 ft)		6.0 m (19.7 ft)		7.5 m (24.6 ft)		Capacity	Reach	
											
9.0 m (29.5 ft)	kg								*4,500	*4,500	4.31
	lb								*9,920	*9,920	(14.2)
7.5 m (24.6 ft)	kg			*4,450	*4,450				*3,510	*3,510	6.17
	lb			*9,810	*9,810				*7,740	*7,740	(20.3)
6.0 m (19.7 ft)	kg			*4,230	*4,230				*3,160	*3,160	7.27
	lb			*9,330	*9,330				*6,970	*6,970	(23.9)
4.5 m (14.8 ft)	kg		*5,190	*5,190	*4,680	*4,680	*4,560	4,290	*3,030	*3,030	7.93
	lb		*11,440	*11,440	*10,320	*10,320	*10,050	9,460	*6,680	*6,680	(26.0)
3.0 m (9.8 ft)	kg		*6,890	*6,890	*5,480	*5,480	*4,890	4,190	*3,040	*3,040	8.27
	lb		*15,190	*15,190	*12,080	*12,080	*10,780	9,240	*6,700	*6,700	(27.1)
1.5 m (4.9 ft)	kg		*8,620	8,600	*6,370	5,640	*5,350	4,080	*3,180	*3,180	8.33
	lb		*19,000	18,960	*14,040	12,430	*11,790	8,990	*7,010	*7,010	(27.3)
Ground Line	kg	*6,800	*6,800	*9,780	8,300	*7,100	5,470	4,000	*3,470	*3,470	8.10
	lb	*14,990	*14,990	*21,560	18,300	*15,650	12,060	8,820	*7,650	*7,650	(26.6)
-1.5 m (-4.9 ft)	kg	*11,610	*11,610	*10,240	8,220	*7,480	5,400	4,000	*4,010	3,950	7.57
	lb	*25,600	*25,600	*22,580	18,120	*16,490	11,900	8,820	*8,840	8,710	(24.8)
-3.0 m (-9.8 ft)	kg			*9,920	8,310	*7,230	5,470				
	lb			*21,870	18,320	*15,940	12,060				

- Lifting capacity are based on ISO 10567.
- Lifting capacity does not exceed 75% of tipping load with the machine on firm, level ground or 87% of full hydraulic capacity.
- The Lift-point is bucket pivot mounting pin on the arm (without bucket mass).
- (*) indicates load limited by hydraulic capacity.

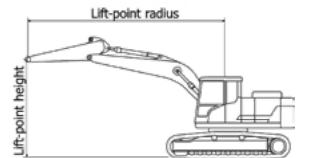

STANDARD & OPTION

MEMO

ENGINE	STD	OPT
Cummins B6.7 engine	●	
HYDRAULIC SYSTEM		
Intelligent Power Control (IPC)		
3-power mode, 2-work mode, user mode	●	
Variable Power Control	●	
Pump Flow Control	●	
Attachment Mode Flow Control		●
Engine Auto Idle	●	
Engine Auto Shutdown Control	●	
Hyundai Bio Hydraulic Oil (HBHO)		●
CAB & INTERIOR		
ISO Standard cabin		
Rise-up type windshield wiper	●	
Radio / USB player	●	
Handsfree mobile phone system with USB	●	
12 volt power outlet (24V DC to 12V DC converter)	●	
Electric horn	●	
All-weather steel cab with 360°visibility	●	
Safety glass - Tempered glass	●	
Safety glass - Tempered glass with front laminated glass	●	
Safety glass windows	●	
Sliding fold-in front window	●	
Sliding side window(LH)	●	
Lockable door	●	
Hot & cool box	●	
Storage compartment & Ashtray	●	
Transparent cabin roof-cover	●	
Sun visor	●	
Door and cab locks, one key	●	
Mechanical suspension seat with heater	●	
Pilot-operated slidable joystick	●	
Console box height adjust system	●	
Automatic climate control		
Air conditioner & heater	●	
Defroster	●	
Starting Aid (air grid heater) for cold weather	●	
Centralized monitoring		
8" LCD display	●	
Engine speed or Trip meter/Accel.	●	
Engine coolant temperature gauge	●	
Max power	●	
Low speed/High speed	●	
Auto idle	●	
Overload warning with alarm		●
Check Engine	●	
Air cleaner clogging	●	
Indicators	●	
ECO Gauges	●	
Fuel level gauge	●	
Hyd. oil temperature gauge	●	
Fuel warmer	●	
Warnings	●	
Communication error	●	
Low battery	●	
Clock	●	
Cabin lights		●
Cabin front window rain guard		●
Seat		
Adjustable air suspension seat with heater		●
Cabin FOPS/FOG		
FOPS (Falling Object Protective Structures)- ISO 10262 Level 2		●
Cabin ROPS		
ROPS (Roll Over Protective Structures)- ISO 12117-2	●	

SAFETY	STD	OPT
Radar with 2nd monitor		●
Battery master switch	●	
Rear view camera		●
Rear & Mirror view camera		●
AAVM (Advanced Around View Monitoring)		●
Four front working lights (2 boom mounted, 2 front frame mounted)	●	
Travel alarm	●	
Rear work lamp		●
Beacon lamp		●
Automatic swing brake	●	
Boom holding system	●	
Arm holding system	●	
Safety lock valve for boom cylinder with overload warning device		●
Safety lock valve for arm cylinder		●
Swing Lock System		●
General Type Guardrail	●	
Separable Type Guardrail		●
ATTACHMENT		
Booms		
5.65 m, 18' 6" Mono	●	
5.40 m, 17' 9" 2-Piece		●
Arms		
2.4 m, 7' 10"	●	
2.7 m, 8' 10"		●
2.92 m, 9' 7"		●
OTHER		
Heavy CWT 3.4 ton		●
Heavy CWT 4.1 ton		●
Removable clean-out dust net for cooler		●
Fuel pre-filter	●	
Fuel Warmer (Single)	●	
Self-diagnostics system	●	
Hi MATE (Remote Management System)	Mobile	●
	Satellite	●
	Dual	●
Batteries (2 x 12V x 100 AH)	●	
Precleaner		●
Fuel filler pump (50 lpm)		●
Single-acting piping kit (breaker, etc.)		●
Double-acting piping kit (clamshell, etc.)		●
Rotating Piping Kit		●
Quick coupler piping		●
Quick coupler		●
Accumulator for lowering work equipment	●	
Pattern change valve (2 patterns)		●
Automatic digging brake		●
Joystick steering		●
Fine Swing Control System		●
Tool kit		●
Auto cruiser system	●	
LED lights on boom (2)		●
UNDERCARRIAGE		
Front outrigger and rear blade	●	
Front and rear outrigger		●
Front blade and rear outrigger		●
Front and rear dozer blade		●
Front grapple rest and rear blade		●
Tires-dual (10.00-20-14PR tube)	●	
Tires-dual (10.00-20-16PR tube)		●
Tires-dual (10.00-20 solid)		●
Fenders (Mudguards)		●
Wide axle 2.75 m		●

* Standard and optional equipment may vary. Contact your Hyundai dealer for more information.
 The machine may vary according to International standards.
 * The photos may include attachments and optional equipment that are not available in your area.
 * Materials and specifications are subject to change without advance notice.
 * All imperial measurements rounded off to the nearest pound or inch.