

STANDARD EQUIPMENT

ISO standard cabin

- Cabin ROPS(ISO 12117-2)
FOPS(ISO 10262 Level1)
TOPS(ISO 12117)
- All-weather steel cab with all-around visibility
- Safety glass windows
- Rise-up type windshield wiper
- Sliding fold-in front window
- Sliding side window
- Lockable door
- Accessory box & Ash-tray

Centralized monitoring

- Engine speed
- Gauges
- Fuel level gauge
- Engine coolant temperature gauge

Warning

- Fuel level
- Engine oil pressure
- Engine coolant temperature
- Hyd. oil temperature
- Low battery
- Air cleaner closing
- Door and cab locks, one key
- Radio / USB player with remote control
- Two outside rear view mirrors
- Fully adjustable suspension seat with seat belt
- Console box tilting system(L.H.)
- Four front working lights
- Electric horn
- Battery (1 x 12 V x 100 AH)
- Battery master switch

12 volt power supply

- Removable clean out screen for radiator
- Automatic swing brake
- Removable reservoir tank
- Water separator, fuel line
- Mono boom (3.0 m, 9'10")
- Arm (1.6 m, 5' 3")
- Track shoes (380 mm, 15")
- Track rail guard
- Starting aid (air grid heater) cold weather
- Viscous fan clutch
- Single acting piping kit (breaker, etc)

OPTIONAL EQUIPMENT

Air-conditioner & heater

- Fuel filler pump (35ℓ/min, 9.2 US gpm)
- Beacon lamp
- Double acting piping kit (clamshell, etc)
- Accumulator, work equipment lowering
- Electric transducer

Travel alarm

- Quick coupler
- Rubber crawler (400mm, 16")
- Long arm (1.9m, 6'3")
- Tool kit
- Track shoes (450mm, 17.7")

Cabin front, rear work lamp

- Track padassy (400mm, shoe hole)
- Safety valve for boom and arm cylinders and overload warning device
- Safety valve for dozer blade cylinder
- Rear view camera

* Standard and optional equipment may vary. Contact your Hyundai dealer for more information. The machine may vary according to International standards.

* The photos may include attachments and optional equipment that are not available in your area.

* Materials and specifications are subject to change without advance notice.

* All imperial measurements rounded off to the nearest pound or inch.



Head Office(Sales Office)
14F, GLOBAL R&D CENTER, 477 BUNDANG SUSEO-RO, BUNDANG-GU, SEONGNAM-SI, GYEONGGI-DO, 13553, KOREA

Robex 55 -9A

With EU Stage V / EPA Tier 4 Final Engine Installed



* Photo may include optional equipment.

PLEASE CONTACT

PRIDE AT WORK

HD Hyundai Construction Equipment strives to build state-of-the-art earthmoving equipment to give every operator maximum performance, more precision, versatile machine preferences, and proven quality. *Take pride in your work with Hyundai!*

Robex 55-9A



* Photo may include optional equipment.

Machine Walk-Around

Engine Technology

The fuel efficient, EU Stage V / EPA Tier 4 Final certified Yanmar 4TNV98C engine provides proven, reliable power. This engine is electronically controlled for optimum fuel to air ratio and clean, efficient combustion and provides low noise.

Rugged Upper and Lower Frame

The upper frame is designed with optimum structural integrity to absorb impact and operational stress. The x-style center frame and reinforced box section track frame provide exceptional strength and longer service life to withstand tough working conditions.

Efficient Control System

All control devices are arranged for higher productivity and improved operator comfort. Efficient and ergonomic controls allow an operator to control the machine in any working environment. A safety lever on the left-side console is provided to prevent exiting the cabin while hydraulic controls are live.

Advanced Hydraulic System

The R55-9A's advanced hydraulic system includes an arm flow summation system, boom holding system and a swing parking brake for smooth and fine control. Other valuable features include a hydraulic damper in the travel pedal, and a hydraulically lubricated swing reducer with a leak-free grease chamber.

Comfortable and Durable Cabin

The cabin is roomy and ergonomically designed, for reduced noise and good visibility. The cabin frame meets international standard TOPS, ROPS, FOPS ensuring operator safety.

Operator Convenience

Convenient operator features include a suspension seat, excellent visibility, and variable storage space for advanced operator comfort. The newly designed LCD cluster provides current information, including engine RPM, engine coolant, fuel level, and electric components. A hydraulic function safety lock and auto diagnostic features are also available. lock and failure diagnosis functions are also intergrated. A powerful air conditioning system and MP3 interface contribute to a productive work environment.

Easy and Simple Maintenance

Wide open access of doors, covers, hoods is designed for easier maintenance. The air cleaner and centralized grease fittings are also integrated for easy service.

Extended Life of Components

Long life components and wear parts, including hydraulic filters, oil, shims, and bushings, help to reduce operating costs.

PREFERENCE

Operating a 9A series is unique to every operator. Operators can fully customize their work environment and operating preferences to fit their individual needs.



* Photo may include optional equipment.



Wide Cabin with Excellent Visibility

The newly designed cabin was conceived for more space, a wider field of view and operator comfort. Special attention was given to a clear, open and convenient interior with plenty of visibility on the machine surroundings and the job at hand. This well balanced combination of precision aspects put the operator in the perfect position to work safely and securely.

Operator Comfort

The R55-9A operator's cab is designed for a comfortable operating experience. An ergonomically designed suspension seat, adjustable arm rests and a spacious environment helps to minimize operator fatigue. Control levers are easily accessible and an instrument display is provided to keep the operator informed of pertinent machine information.

1. A large upper roof glass provides additional visibility and a roller shade is provided to reduce glare and sunlight.
2. An advanced audio system with AM/FM stereo with USB player, plus remotely located control is perfect for listening to music favorites.
3. A hands-free cell phone function is available for safe and convenient phone use.
4. Ergonomically designed joysticks reduce operator fatigue during the work day.
5. Multiple storage compartments are available for additional convenience.



Enhanced Cabin

Hyundai's R55-9A is equipped for convenience and productivity.

1. Adjustable position window prevents window movement while operating.
2. A sliding fold-in front window is easily opened and safely stored in an open position to improve ventilation and visibility.
3. A tilt-up left side control console provides easier entrance and exit from the cab.
4. A power climate control system provides the operator with optimum air temperature.



Operator - Friendly Cluster

The advanced new LCD cluster allows the operator to select his personal machine preferences. The monitor displays engine rpm, engine oil temperature, water temperature and information for all electronic devices.

Button selections are provided for auto idle mode, max power mode, and travel speed. A security feature is also provided to prevent the machine from starting without a proper password.

PERFORMANCE

9A series is designed for maximum performance to keep the operator working productively.



* Photo may include optional equipment.

Excellent Performance

Hyundai's 9A series offers the operator maximized productivity and efficiency. A convenient throttle volume dial with LED light allows the operator to customize engine power according to job requirements. A max power button maximizes machine speed and power for mass production. The R55-9A also features an auto idle system which improves fuel efficiency and reduces cab noise.

Improved Hydraulic System



To achieve optimum precision, Hyundai redesigned the hydraulic system to provide the operator with super fine touch and improved controllability. Improved pump flow control reduces flow when controls are not being used to minimize fuel consumption. Improved spool valves in the control valve are engineered to provide more precise flow to each function with less effort. Improved hydraulic valves, precision-designed variable volume piston pumps, fine-touch pilot controls, and enhanced travel functions make any operator running a 9A series look like a smooth operator. Boom-down flow regeneration and control valve technology are newly improved.

Variable Swing Boom

The R55-9A's boom swing function is designed for efficient work in congested residential and urban areas. The boom can be offset left or right within an operating range. Plus, increased swing torque provides enhanced operating capability on the slope.

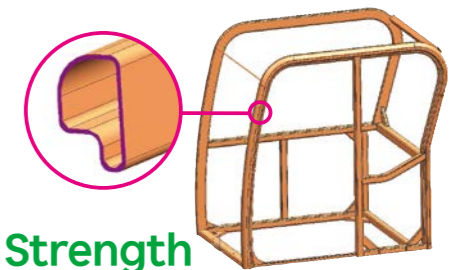

Structure Strength

The 9A series cabin structure has been fitted with stronger but slimmer tubing for more safety and improved visibility. Low-stress, high strength steel is integrally welded to form a stronger, more durable upper and lower frame. Structural integrity was tested by way of FEM (Finite Elements Method) analysis and long-term durability tests.

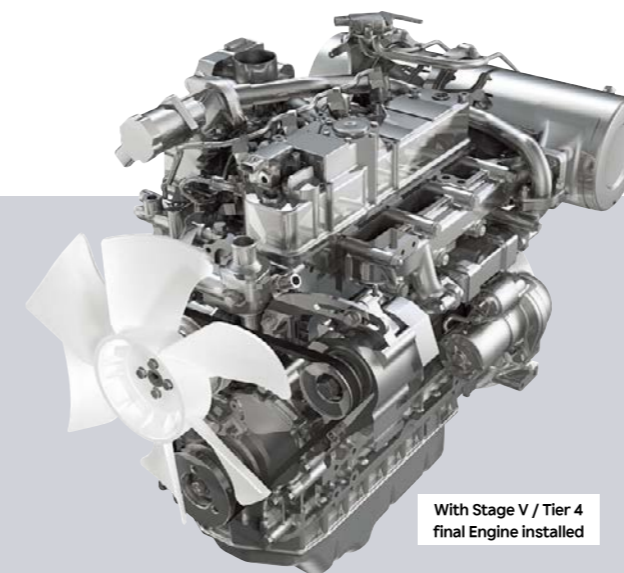

With Stage V / Tier 4 final Engine installed

Yanmar 4TNV98C

The Highest Engine Power in its Class

Yanmar 4TNV98C engine provides 24 kgf.m (174 lbf.ft) of maximum torque with 66.9 HP at 2,400rpm of rated power. This means the R55-9A runs with the most power in its class, giving you more power to get the job done.

PROFITABILITY

9A series is designed to maximize profitability through improved efficiencies, enhanced service features and longer life components.



* Photo may include optional equipment.

Fuel Efficient

9A series compact excavators are engineered to be extremely fuel efficient.



Improved Durability

The R55-9A is equipped with counter weight rear guards to protect the engine hood. Boom cylinder cover provides added protection on the tough working condition.

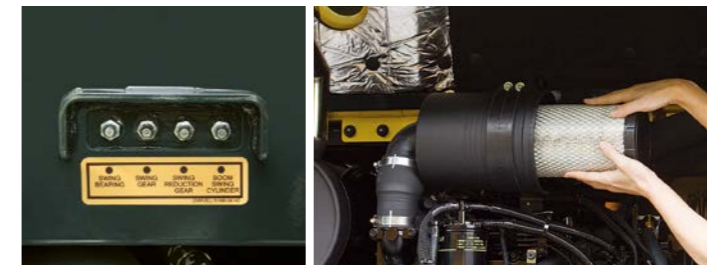

Easy Access

Centralized grease fittings and easy change plastic air cleaner provide faster, easier service and maintenance.

Wide Open Engine hood

A newly designed full-open type engine hood makes service more convenient on the R55-9A.

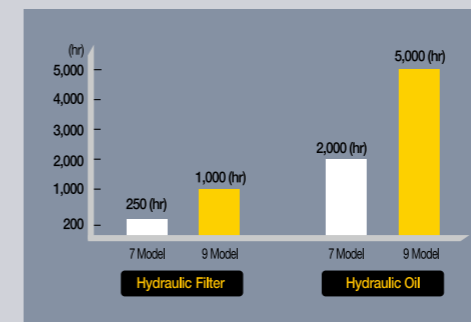

Extended Life Components

9A series excavators were designed with bushings designed for extended lube intervals (250 hrs) & polymer shims (wear resistant, noise reducing), extended-life hydraulic filters (1,000hrs), long-life hydraulic oil (5,000hrs), more efficient cooling systems and integrated preheating systems which extend service intervals, minimize operating costs and reduce machine down time.

SPECIFICATIONS

ENGINE

MODEL		YANMAR 4TNV98C	
Type		Water cooled, 4 cycle diesel 4 cylinders in line, direct injection, low emission	
Rated flywheel horsepower	SAE	J1995 (gross)	66.9 HP (49.9 kW) at 2,400 rpm
		J1349 (net)	64.6 HP (48.2 kW) at 2,400 rpm
	DIN	6271/1 (gross)	67.8 PS (49.9 kW) at 2,400 rpm
		6271/1 (net)	65.5 PS (48.2 kW) at 2,400 rpm
Max. torque		24 kgf·m (174 lbf·ft) at 1,560 rpm	
Bore X stroke		98 mm (3.86") x 110 mm (4.33")	
Piston displacement		3,319 cc (203 cu in)	
Batteries		1 x 12 V x 100 AH	
Starting motor		12V-3.0 kW	
Alternator		12V-100 Amp	

HYDRAULIC SYSTEM

MAIN PUMP	
Type	Two variable displacement piston pumps
Max. flow	2 X 57.8 l/min(15.3 US gpm/12.7 UK gpm)pumps
Sub-pump for pilot circuit	Gear pump
Cross-sensing and fuel saving pump system	

HYDRAULIC MOTORS	
Travel	Two speed axial piston motor with counter balance valve and parking brake
Swing	Axial piston motor with automatic brake

RELIEF VALVE SETTING	
Implement circuits	220 kgf/cm ² (3,130 psi)
Travel circuit	220 kgf/cm ² (3,130 psi)
Swing circuit	220 kgf/cm ² (3,130 psi)
Pilot circuit	30 kgf/cm ² (430 psi)
Service valve	Installed

HYDRAULIC CYLINDERS	
No. of cylinder bore X stroke	Boom: 1-110 x 715 mm (4.3" x 28.1")
	Arm: 1-90 x 850 mm (3.5" x 33.5")
	Bucket: 1-80 x 660 mm (3.1" x 26.0")
	Boom swing: 1-95 x 527 mm (3.7" x 20.7")
Dozer blade: 1-110 x 224 mm (4.3" x 8.8")	

TRAVEL SYSTEM

Drive method	Full hydrostatic type
Drive motor	Axial piston motor, in-shoe design
Reduction system	Planetary reduction gear
Max. drawbar pull	5,300 kgf (11,700 lbf)
Max. travel speed(high) / (low)	4.1 km/hr (2.5 mph) / 2.1 km/hr (1.3 mph)
Gradeability	35° (70%)
Parking brake	Multi-wet disc

CONTROLS

Pilot pressure operated joysticks and pedals with detachable lever provide almost effortless and fatigueless operation.

Pilot control	Two joysticks with one safety lever (LH): Swing & Arm (RH): Boom and bucket (ISO)
Traveling and steering	Two levers with pedals
Engine throttle	Electric, Dial type

SWING SYSTEM

Swing motor	Axial piston motor
Swing reduction	Planetary gear reduction
Swing bearing lubrication	Grease-bathed
Swing brake	Multi wet disc
Swing speed	9.1 rpm

COOLANT & LUBRICANT CAPACITY

(Refilling)	liter	US gal	UK gal
Fuel tank	125.0	33.0	27.5
Engine coolant	9.5	2.5	2.1
Engine oil	11.6	3.1	2.6
Swing device-gear oil	1.5	0.4	0.3
Final drive(each)	1.2	0.3	0.3
Hydraulic tank	70.0	18.5	15.4
Hydraulic system	120.0	31.7	26.4

UNDERCARRIAGE

X-leg type center frame is integrally welded with reinforced box-section track frames. The undercarriage includes lubricate rollers, track adjusters with shock absorbing springs and sprockets, and track chain with triple grouser shoes.

Center frame	X - leg type
Track frame	Pentagonal box type
No. of track shoe on each side	40
No. of upper roller on each side	1
No. of lower roller on each side	5

OPERATING WEIGHT (APPROXIMATE)

Operating weight, including 3,000 mm (9' 10") boom, 1,600 mm (5' 3") arm, SAE heaped 0.18 m³ (0.24 yd³) digging bucket, lubricant, coolant, full fuel tank, hydraulic tank and the standard equipment.

MAJOR COMPONENT WEIGHT	
Upperstructure	2,710 kg (5,970 lb)
Mono boom(with arm cylinder)	310 kg (680 lb)
OPERATING WEIGHT	
Operating weight	5,650 kg (12,460 lb)

*Mono boom with blade

BUCKETS

Capacity		Width		Weight
SAE heaped	CECE heaped	Without side cutters	With side cutters	
0.07 m ³ (0.09 yd ³)	0.06 m ³ (0.08 yd ³)	315 mm(12.4")	360 mm(14.2")	115 kg(255 lb)
0.18 m ³ (0.24 yd ³)	0.15 m ³ (0.20 yd ³)	670 mm(26.4")	740 mm(29.1")	170 kg(375 lb)

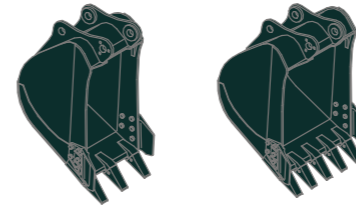

SAE heaped 0.07 m³ (0.09 yd³) ISO heaped 0.18 m³ (0.24 yd³)

DIGGING FORCE

Arm	Length	1,600 mm (5' 3")	1,900 mm (6' 3")
	Weight	210 kg (460 lb)	230 kg (510 lb)
Bucket digging force	SAE	37.7 kN	37.7 kN
		3,850 kgf	3,850 kgf
	ISO	8,490 lbf	8,490 lbf
		42.4 kN	42.4 kN
Arm crowd force	SAE	4,330 kgf	4,330 kgf
		9,550 lbf	9,550 lbf
	ISO	28.4 kN	25.5 kN
		2,900 kgf	2,600 kgf
ISO	6,390 lbf	5,730 lbf	
	31.9 kN	28.7 kN	
		3,260 kgf	2,930 kgf
		7,190 lbf	6,460 lbf

*Arm weight including cylinder and linkage.

LIFTING CAPACITY

R55-9A

Rating over-front Rating over-side or 360 degree

Boom : 3.0m (9' 10") / Arm : 1.6 m (5' 3") / Bucket : 0.18m³ (0.24yd³) SAE heaped / Dozer blade down

Load point height m (ft)	Load radius								At max. reach			
	2.0 m (7 ft)		3.0 m (10 ft)		4.0 m (13 ft)		5.0 m (16 ft)		Capacity	Reach		
5.0 m (16 ft)	kg								*950	*950	4.12	
	lb								*2,090	*2,090	(13.5)	
4.0 m (13 ft)	kg				*1,020	*1,020			*980	780	5.08	
	lb				*2,250	*2,250			*2,160	1,720	(16.7)	
3.0 m (10 ft)	kg				*1,090	*1,090			*1,010	650	5.60	
	lb				*2,400	*2,400			*2,230	1,430	(18.4)	
2.0 m (7 ft)	kg	*3,050	*3,050	*1,690	*1,690	*1,320	1,100	*1,170	760	*1,050	590	5.84
	lb	*6,720	*6,720	*3,730	*3,730	*2,910	2,430	*2,580	1,680	*2,310	1,300	(19.2)
1.0 m (3 ft)	kg			*2,360	1,610	*1,600	1,040	*1,280	740	*1,100	580	5.85
	lb			*5,200	3,550	*3,530	2,290	*2,820	1,630	*2,430	1,280	(19.2)
Ground Line	kg	*2,350	*2,350	*2,700	1,540	*1,790	1,000	*1,350	720	*1,140	610	5.63
	lb	*5,180	*5,180	*5,950	3,400	*3,950	2,200	*2,980	1,590	*2,510	1,340	(18.5)
-1.0 m (-3 ft)	kg	*3,600	3,020	*2,670	1,530	*1,800	990			*1,180	700	5.13
	lb	*7,940	6,660	*5,890	3,370	*3,970	2,180			*2,600	1,540	(16.8)
-2.0 m (-7 ft)	kg	*3,770	3,060	*2,300	1,540					*1,140	960	4.23
	lb	*8,310	6,750	*5,070	3,400					*2,510	2,120	(13.9)
-3.0 m (-10 ft)	kg	*2,040	*2,040									
	lb	*4,500	*4,500									

- Lifting capacity is based on SAE J1097, ISO 10567.
- Lifting capacity of the Robex Series does not exceed 75% of the tipping load with the machine on firm, level ground or 87% of full hydraulic capacity.
- The load point is a hook located on the back of the bucket.
- (*) indicates the load limited by hydraulic capacity.

Caution : Please be aware of the local regulation and instructions for lifting operations.

LIFTING CAPACITY

R55-9A

Rating over-front Rating over-side or 360 degree

Boom : 3.0m (9' 10") / Arm : 1.6 m (5' 3") / Bucket : 0.18m³ (0.24yd) SAE heaped / Dozer blade up

Load point height m (ft)	Load radius								At max. reach		
	2.0 m (7 ft)		3.0 m (10 ft)		4.0 m (13 ft)		5.0 m (16 ft)		Capacity	Reach	
5.0 m (16 ft)	kg								*950	*950	4.12
	lb										
4.0 m (13 ft)	kg					*1,020	*1,020		*2,090	*2,090	(13.5)
	lb					*2,250	*2,250		*980	740	5.08
3.0 m (10 ft)	kg					*1,090	1,080		*2,160	1,630	(16.7)
	lb					*2,400	2,380		890	610	5.60
2.0 m (7 ft)	kg	*3,050	*3,050	*1,690	1,630	*1,320	1,030	1,040	1,960	1,340	(18.4)
	lb	*6,720	*6,720	*3,730	3,590	*2,910	2,270	2,290	810	550	5.84
1.0 m (3 ft)	kg			2,250	1,510	1,430	980	1,010	1,570	1,210	(19.2)
	lb			4,960	3,330	3,150	2,160	2,230	690	540	5.85
Ground	kg	*2,350	*2,350	2,170	1,440	1,390	940	990	1,760	1,190	(19.2)
Line	lb	*5,180	*5,180	4,780	3,170	3,060	2,070	2,180	840	570	5.63
-1.0 m (-3 ft)	kg	*3,600	2,780	2,150	1,420	1,370	930	1,480	1,850	1,260	(18.5)
	lb	*7,940	6,130	4,740	3,130	3,020	2050		970	660	5.13
-2.0 m (-7 ft)	kg	*3,770	2,830	2,170	1,440				2,140	1,460	(16.8)
	lb	*8,310	6,240	4,780	3,170				*1,140	900	4.23
-3.0 m (-10 ft)	kg	*2,040	*2,040						*2,510	1,980	(13.9)
	lb	*4,500	*4,500								

Boom : 3.0m (9' 10") / Arm : 1.9 m (6' 3") / Bucket : 0.18m³ (0.24yd) SAE heaped / Dozer blade down

Load point height m (ft)	Load radius								At max. reach			
	2.0 m (7 ft)		3.0 m (10 ft)		4.0 m (13 ft)		5.0 m (16 ft)		Capacity	Reach		
5.0 m (16 ft)	kg								*870	*870	4.58	
	lb											
4.0 m (13 ft)	kg								*1,920	*1,920	(15.0)	
	lb								*900	700	5.43	
3.0 m (10 ft)	kg					*950	*950	*990	*1,980	1,540	(17.8)	
	lb					*2,090	*2,090	*2,180	810	550	5.91	
2.0 m (7 ft)	kg			*1,440	*1,440	*1,190	1,110	*1,080	1,720	*2,050	1,300	(19.4)
	lb			*3,170	*3,170	*2,620	2,450	*2,380	760	*970	540	6.13
1.0 m (3 ft)	kg	*2,050	*2,050	*2,160	1,630	*1,500	1,050	*1,220	1,680	*2,140	1,190	(20.1)
	lb	*4,520	*4,520	*4,760	3,590	*3,310	2,310	*2,690	740	*1,020	530	6.14
Ground	kg	*2,280	*2,280	*2,610	1,540	*1,730	1,000	*1,320	1,630	*2,250	1,170	(20.1)
Line	lb	*5,030	*5,030	*5,750	3,400	*3,810	2,200	*2,910	710	*1,060	550	5.93
-1.0 m (-3 ft)	kg	*3,230	2,980	*2,700	1,510	*1,810	980	*1,310	1,570	*2,340	1,210	(19.5)
	lb	*7,120	6,570	*5,950	3,330	*3,990	2,160	*2,890	700	*1,100	620	5.48
-2.0 m (-7 ft)	kg	*4,140	3,020	*2,450	1,520	*1,630	980		1,540	*2,430	1,370	(18.0)
	lb	*9,130	6,660	*5,400	3,350	*3,590	2,160			*1,100	810	4.67
-3.0 m (-10 ft)	kg	*2,760	*2,760	*1,640	1,570					*2,430	1,790	(15.3)
	lb	*6,080	*6,080	*3,620	3,460							

Boom : 3.0m (9' 10") / Arm : 1.9 m (6' 3") / Bucket : 0.18m³ (0.24yd) SAE heaped / Dozer blade up

Load point height m (ft)	Load radius								At max. reach			
	2.0 m (7 ft)		3.0 m (10 ft)		4.0 m (13 ft)		5.0 m (16 ft)		Capacity	Reach		
5.0 m (16 ft)	kg								*870	*870	4.58	
	lb											
4.0 m (13 ft)	kg								*1,920	*1,920	(15.0)	
	lb								*900	660	5.43	
3.0 m (10 ft)	kg					*950	*950	*990	*1,980	1,460	(17.8)	
	lb					*2,090	*2,090	*2,180	810	550	5.91	
2.0 m (7 ft)	kg			*1,440	*1,440	*1,190	1,040	1,040	1,630	1,210	(19.4)	
	lb			*3,170	*3,170	*2,620	2,290	2,290	720	500	6.13	
1.0 m (3 ft)	kg	*2,050	*2,050	*2,160	1,530	1,440	980	1,010	1,590	1,650	1,100	(20.1)
	lb	*4,520	*4,520	*4,760	3,370	3,170	2,160	2,230	690	740	490	6.14
Ground	kg	*2,280	*2,280	2,170	1,440	1,390	940	990	1,520	1,630	1,080	(20.1)
Line	lb	*5,030	*5,030	4,780	3,170	3,060	2,070	2,180	670	770	510	5.93
-1.0 m (-3 ft)	kg	*3,230	2,740	2,140	1,410	1,360	910	980	1,480	1,700	1,120	(19.5)
	lb	*7,120	6,040	4,720	3,110	3,000	2,010	2,160	660	870	580	5.48
-2.0 m (-7 ft)	kg	*4,140	2,780	2,150	1,420	1,370	920	1,490	1,920	1,280	(18.0)	
	lb	*9,130	6,130	4,740	3,130	3,020	2,030		*1,100	760	4.67	
-3.0 m (-10 ft)	kg	*2,760	*2,760	*1,640	1,470				*2,430	1,680	(15.3)	
	lb	*6,080	*6,080	*3,620	3,240							

- Lifting capacity is based on SAE J1097, ISO 10567.
- Lifting capacity of the Robex Series does not exceed 75% of the tipping load with the machine on firm, level ground or 87% of full hydraulic capacity.
- The load point is a hook located on the back of the bucket.
- (*) indicates the load limited by hydraulic capacity.

Caution : Please be aware of the local regulation and instructions for lifting operations.

DIMENSIONS & WORKING RANGE

R55-9A DIMENSIONS

unit: mm(ft · in)

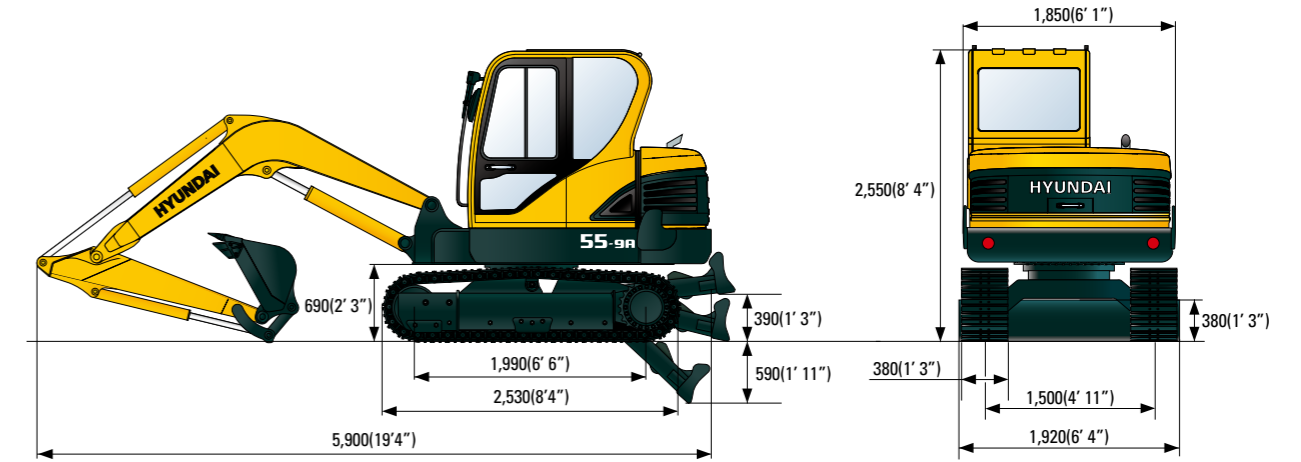

R55-9A WORKING RANGE

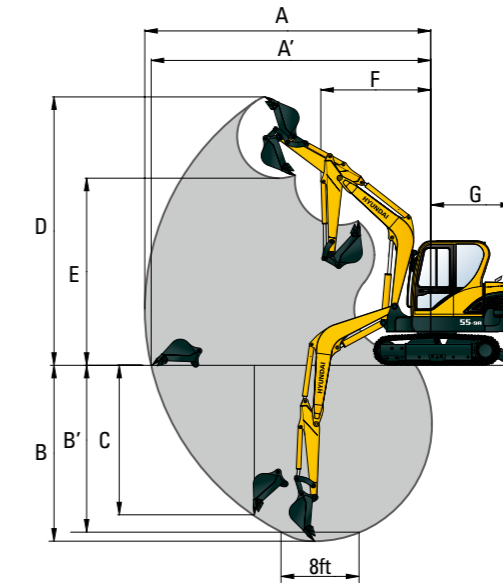

unit: mm(ft · in)

Boom length	3,000 (9' 10")	
Arm length	1,600 (5' 3")	1,900 (6' 3")
A Max. digging reach	6,150 (20' 2")	6,400 (20' 1")
A' Max. digging reach on ground	6,010 (19' 9")	6,270 (20' 7")
B Max. digging depth	3,820 (12' 6")	4,060 (13' 4")
B' Max. digging depth (8ft level)	3,420 (11' 3")	3,700 (12' 2")
C Max. vertical wall digging depth	3,200 (10' 6")	3,460 (11' 4")
D Max. digging height	5,780 (18' 12")	5,920 (19' 5")
E Max. dumping height	4,050 (13' 3")	4,180 (13' 9")
F Min. swing radius	2,350 (7' 9")	2,360 (7' 9")
G Tail swing radius	1,650 (5' 5")	1,650 (5' 5")

